

Manual of Operation and Instruction

Model 3440

Surface Moisture-Density Gauge



Troxler Electronic Laboratories, Inc.

3008 Cornwallis Rd. • P.O. Box 12057

Research Triangle Park, NC 27709

Phone: 1.877.TROXLER

Outside the USA: +1.919.549.8661

Fax: +1.919.549.0761

www.troxlerlabs.com

Troxler products are protected by U.S. and foreign patents.

Copyright ♥ 1989–2009

Troxler Electronic Laboratories, Inc.

All Rights Reserved

No part of this manual may be reproduced or transmitted in any form or by any means, electronic or mechanical, including photocopying, recording, or information storage and retrieval systems, for any purpose without the express written permission of Troxler Electronic Laboratories, Inc.

Adobe and *Acrobat* are trademarks of Adobe Systems Incorporated, and are registered in certain jurisdictions.

Fantastic is a trademark of Dow Consumer Products, Inc.

409 is a trademark of the Clorox Company.

Magnalube-G is a registered trademark of Carleton-Stuart Corporation.

Microsoft, Excel, Windows, Windows 95, Windows 98, and Word are registered trademarks of Microsoft Corporation.

PN 104279
January 2009
Edition 17.7

 **SAFETY ALERT SYMBOL** 

The Safety Alert Symbol shall appear within this manual. Wherever it appears in this manual or on safety signs affixed to the machine, this is to make all aware of the potential for personal injury and to be cautious when these images are present.

Always observe all WARNING, CAUTION, and NOTE recommendations listed within this manual before operating the machine.



TROXLER SERVICE CENTERS

Troxler Corporate Headquarters

3008 Cornwallis Road
P.O. Box 12057
Research Triangle Park, NC 27709
Phone: 1.877.TROXLER (1.877.876.9537)
Outside the U.S.A.: +1.919.549.8661
Fax: +1.919.549.0761
Web: www.troxlerlabs.com

Technical Support

Phone: 1.877.TROXLER (1.877.876.9537)
E-mail: TroxTechSupport@troxlerlabs.com

Florida Service Center

2376 Forsyth Road
Orlando, FL 32807
Fax: 407.681.3188

Texas Service Center

2016 East Randol Mill Road
Suite 406
Arlington, TX 76011
Fax: 817.275.8562

Illinois Service Center

1430 Brook Drive
Downers Grove, IL 60515
Fax: 630.261.9341

Northern California Service Center

11300 Sanders Drive, Suite 7
Rancho Cordova, CA 95742
Fax: 916.631.0541

Troxler European Subsidiary

Troxler Electronics GmbH
Gilchinger Strasse 33
D.82239 Alling nr. Munich, Germany
Phone: ++49.8141.71063
Fax: ++49.8141.80731
E-mail: troxler@t-online.de

NOTE

To locate an independent, Troxler-authorized service center near you, call 1.877.TROXLER (1.877.876.9537).



CAUTIONS AND WARNINGS



Units intended for use in countries that are members of the European Community are shipped with a CE approved AC adapter, Troxler bin number 108354.



Gauge cover is to be removed by trained service personnel only. No user-serviceable components inside. Note: Components behind cover can have voltage potentials in excess of 50 volts during normal operation of the gauge.



Appendix C – Radiological Safety should be read carefully and understood before using the gauge.



Alkaline Battery Use: See page F-2.
Safety Glasses: See page 3-2.



The source rod should automatically retract to the SAFE position when the gauge is lifted.



See *Scraper Ring/Tungsten Sliding Block Maintenance* on page F-5.

EU DECLARATION OF CONFORMITY

Application of Council EMC Directive 89/336/EEC and Low Voltage Directive 73/23/EEC

Standards to which Conformity is Declared:

EN 61010-1
EN 55011 Group 1, Class A
EN 50082-2

An **EMC Technical Report/Certificate** has been issued in accordance with Part IV (Reg 50) of the UK Regulations (SI 1992 No. 2372) by a UK appointed Competent Body, namely,

Interference Technology International Limited
41-42 Shrivenham, Hundred Business Park
Shrivenham, Swindon, Wiltshire SN6 8TZ

Certificate Number C283TRO.1ABS Dated 16th January 1997
Troxler Document Number 108205

Manufacturer: Troxler Electronic Laboratories, Inc.
P.O. Box 12057
3008 Cornwallis Road
Research Triangle Park, North Carolina 27709
USA

Apparatus: Model 3440 Surface Moisture-Density Gauge

Year of Declaration 1997 (Original)
2006 (Corrected)

NOTES

TABLE OF CONTENTS

CHAPTER 1. INTRODUCTION TO THE SERIES 3400

Introduction.....	1-2
Gauge and Accessories.....	1-4
Control Panel Keypad	1-6

CHAPTER 2. GETTING STARTED

Turning the Gauge On.....	2-2
Basic Parameter Setup.....	2-4
Taking the Standard Count.....	2-13

CHAPTER 3. MEASUREMENT SITE PREPARATION

Soil and Base Course Preparation	3-2
Asphalt Surface Preparation.....	3-4

CHAPTER 4. TAKING A DENSITY/MOISTURE MEASUREMENT

Taking a Reading	4-2
Storing a Reading.....	4-4

CHAPTER 5. 3440 OPERATIONS

Offsetting a Reading	5-3
Count Time Function	5-12
Store Function	5-12
Proctor/Marshall/Voidless Function.....	5-13
Status Function.....	5-16
Mode Function	5-17
Project Function	5-17
Print Function.....	5-18
Erase Function.....	5-21
Counts Function	5-21
Recall Function	5-22
Depth Function.....	5-22
Calculator Function.....	5-24

CHAPTER 6. SPECIAL FUNCTIONS

Stat Test.....	6-3
Drift Test.....	6-7
Recover Erase.....	6-9
Keypad Data.....	6-10
Auto-Station	6-11
Special Calibration	6-12
Nomograph.....	6-15
Precision.....	6-22
Set Units.....	6-24
Baud Rate.....	6-25

TABLE OF CONTENTS (Continued)

CHAPTER 6. SPECIAL FUNCTIONS (Continued)

Communication Protocol	6-26
Battery Monitor.....	6-27
Source Decay	6-30
Special Roadway.....	6-31

CHAPTER 7. EXTENDED FUNCTIONS

Time/Date	7-2
Customer Name.....	7-3
Serial Number	7-4
Calibration Date	7-5
Calibration Constants	7-6
Rod Length.....	7-8
Erase Standard Counts	7-9
Memory Clear	7-10
Burn-In.....	7-10
Calibration Standard.....	7-11
Remote Control.....	7-12

APPENDIX A. THEORY OF OPERATION

Density	A-2
Moisture	A-5

APPENDIX B. RADIATION THEORY

Atomic Structure.....	B-2
Radiation Theory.....	B-3
Radiation Statistics.....	B-4
Radiation Terminology	B-5

APPENDIX C. RADIOLOGICAL SAFETY

Radiation Types	C-2
Radiation Exposure.....	C-3
Monitoring Radiation.....	C-4
3440 Radiation Profile	C-4
Source Encapsulation.....	C-6
Emergency Procedures.....	C-6

APPENDIX D. LICENSING REQUIREMENTS

Specific License	D-2
Radiation Safety Program	D-2
Personnel Monitoring.....	D-2
Security	D-2
Training.....	D-3

TABLE OF CONTENTS (Continued)

APPENDIX D. LICENSING REQUIREMENTS (Continued)

Leak Test.....	D-3
Notice to Employees	D-3
Incidents.....	D-3
Disposal.....	D-4
Record Keeping.....	D-4

APPENDIX E. TRANSPORTATION AND SHIPPING

U.S. Requirements	E-2
Canadian Shipping Requirements	E-4

APPENDIX F. PERIODIC MAINTENANCE AND SERVICE

Batteries	F-2
Mechanical Maintenance.....	F-4
Electronic Maintenance.....	F-9
Replacement Parts	F-16
Returning a Gauge for Service	F-27

APPENDIX G. 3440 SPECIFICATIONS

Measurement Specifications.....	G-2
Calibration Specifications	G-3
Radiological Specifications	G-3
Memory Specifications	G-3
Electrical Specifications	G-4
Mechanical Specifications.....	G-5

APPENDIX H. LOG FORMS & COMPACTION TEST DATA

APPENDIX I. UNIT CONVERSION

Measurement Units	2
Radiological Units.....	2

APPENDIX J. PRINTING (UPLOADING) PROJECT DATA

Windows Hyperterminal	J-2
Viewing Project Data	J-4

INDEX

WARRANTY

LIST OF FIGURES

<u>Figure</u>	<u>Title</u>	<u>Page</u>
1-1	3440 Gauge and Standard Accessories.....	1-5
1-2	3440 Keypad Layout	1-7
2-1	3440 Gauge Showing Rod Positions	2-14
2-2	Gauge Position on Reference Standard Block.....	2-15
3-1	Drill Rod and Extraction Tool with Scraper Plate.....	3-2
3-2	Marking the Test Area.....	3-3
5-1	Gauge and Reference Standard Block Position for Trench Offset.....	5-11
5-2	Serial Port Location.....	5-18
5-3	Sample Project Printouts	5-20
5-4	Calculator Function Keys.....	5-24
6-1	Stat Test Printout Sample	6-6
6-2	Drift Test Printout Sample	6-8
A-1	Direct Transmission Geometry	A-2
A-2	Backscatter Geometry	A-3
A-3	Depth of Top Layer.....	A-4
A-4	Effect of Moisture on Depth of Measurement.....	A-7
B-1	Diagram of an Atom.....	B-2
B-2	Variation of Radioactive Emission.....	B-4
C-1	Effect of Distance on Exposure.....	C-3
C-2	3440 Gauge and Transport Case.....	C-4
D-1	Sample Notice to Employees	D-6
F-1	Retaining and Scraper Rings	F-5
F-2	3440 Baseboard Assembly	F-9
F-3	3440 Gauge Assembly (Sheet 1 of 2).....	F-16
F-4	3440 Base Mechanical Assembly.....	F-20
F-5	3440 Source Rod Handle Assembly.....	F-20
F-6	3440 Preamplifier Assembly	F-22
F-7	3440 Front Panel Assembly	F-24

LIST OF TABLES

<u>Table</u>	<u>Title</u>	<u>Page</u>
1-1	3440 Keypad Functions.....	1-8
A-1	Neutron Thermalization and Absorption Data.....	A-6
C-1	Radiation Dose Equivalent Rates in Millirems per Hours	C-5
F-1	3440 Gauge Assembly Parts.....	F-18
F-2	3440 Base Mechanical Assembly Parts	F-21
F-3	3440 Source Rod Handle Assembly Parts	F-21
F-4	3440 Preamplifier Assembly Parts	F-23
F-5	3440 Front Panel Assembly Parts.....	F-25

NOTES

ATTENTION GAUGE OWNER

*This gauge contains functions that require an **ACCESS CODE**. This code must be entered before these functions may be used. For more information on using the access code, refer to the specific function in Chapter 7.*

The ACCESS CODE for this gauge is:

4688 (Denmark only 2037)

This page should be removed if the access code is not to be distributed to other parties or users of this gauge.

NOTES

CHAPTER 1**INTRODUCTION TO THE SERIES 3400**

This chapter will familiarize the operator with the features and capabilities of the Troxler Model 3440 Surface Moisture-Density Gauge. A brief introduction to the system, as well as illustrations of the important components of the system, are included. Taking time to review this chapter before beginning operation of the system will help the operator to gain a more complete understanding of system operations.

CONTENTS

Introduction	1-2
Gauge and Accessories.....	1-4
Control Panel Keypad	1-6

INTRODUCTION

The Troxler Model 3440 Surface Moisture-Density Gauge measures the moisture content, density, and compaction of soils, soil-stone aggregates, concrete, asphalt treated bases, asphalt surfacing, and other materials that approximate similar ranges of density and/or moisture content. Currently recognized as the industry standard for compacting control instrumentation, the Model 3440 complies with the following American Society of Testing and Materials (ASTM) Standards:

- ◆ *ASTM D-2922: Standard Test Methods for Density of Soil and Soil-Aggregate in Place by Nuclear Methods (Shallow Depth)*
- ◆ *ASTM D-2950: Standard Test Method for Density of Bituminous Concrete in Place by Nuclear Method*
- ◆ *ASTM D-3017: Standard Test Method for Water Content of Soil and Rock in Place by Nuclear Methods (Shallow Depth)*

The latest engineering, design, and manufacturing techniques have been incorporated, as well as over thirty years of experience in the nuclear gauge industry. The result of this effort is the ultimate in surface moisture-density gauges – the Troxler Model 3440 Surface Moisture-Density Gauge.

The versatile 3440 gauge uses two modes of operation (backscatter and direct transmission) and can store over 450 readings. The gauge also provides over 30 special functions and operator-selectable precision for all phases of construction material testing. The LCD display and easy-to-use keypad ensure the operator of fast, accurate test measurement results.

This manual contains sections that cover basic gauge setup and operation, as well as advanced operating techniques. The appendices provide information on radiation theory and radiation safety. Each chapter contains a table of contents for quickly locating the function required. If a question arises about the gauge, gauge operation, or an application not covered by this manual, please contact the closest Troxler Sales/Service Center or your Troxler Representative.

Changes and additions may be made to the 3440 gauge and this manual without notice. Acquire updated information or a newer version of this manual by contacting the Troxler Sales Department or a Troxler Representative. The current edition of the manual can also be downloaded and/or viewed (using Adobe→ Acrobat→ Reader) from the Troxler website, www.troxlerlabs.com.

Some information contained in this manual is used in training courses offered by Troxler Electronic Laboratories, Inc., to assist purchasers in obtaining a Radioactive Materials License from the U.S. Nuclear Regulatory Commission (NRC) or an Agreement State. Owners are encouraged to require study of this manual by operator(s) before allowing any use of the instrument.



While no radiation hazard is imposed on operator(s) during normal use, a potential hazard does exist if improperly used. The sections of the manual covering radiological safety should be required reading for all operators and potential operators. If these sections are not completely understood, operators should seek assistance from Troxler, an appointed Troxler representative or others designated within the operator organization. Additional nuclear safety information is available by attending a *Troxler Nuclear Gauge Training Course*.

As changes are made to local, state, and federal regulations on a continuing basis, the owner/operator must maintain a knowledge of these regulations. *The responsibility for compliance ultimately falls upon the owner*. The owner may also wish to purchase and subscribe to Titles 10 and 49 of the U.S. Code of Federal Regulations in addition to applicable local/state regulations pertinent to the owner's license.

Any licensing issues discussed in this manual are for the United States. To purchase a Model 3440 in Canada, owners must obtain a radioisotope license from the Canadian Nuclear Safety Commission (CNSC). The owner should obtain copies of the CNSC Regulations and the Transportation of Dangerous Goods Act and Regulations. This manual provides a guide to Canadian shipping requirements on page E-4.



NOTE

International communities should follow local regulations regarding products utilizing radioactive materials.

GAUGE AND ACCESSORIES

The Troxler 3440 gauge provides a fast, accurate, and inexpensive way to find the moisture content and density of construction type materials. Take a moment to become familiar with the features and controls of the 3440, its components, operating principles, safeguards and cautions. Use Figure 1-1 and the list below to identify the gauge and standard accessories as they are unpacked.

1. The **GAUGE** is the portable surface moisture-density gauge containing the radioactive sources, electronics and rechargeable battery packs. The gauge serial number appears on the gauge handle and the reference standard block, as well as on the calibration, source, and warranty certificates.
2. The **REFERENCE STANDARD BLOCK** is primarily used to establish standard counts against which future measurements are compared. The reference standard block is also an unchanging reference for long-term stability checks.
3. The **SCRAPER PLATE/DRILL ROD GUIDE** is used to prepare the test site. It is used to guide the drill rod in preparing a hole for the source rod for direct transmission measurements.
4. The **DRILL ROD** is used to drill a hole for direct transmission measurements. **Under no circumstances should the source rod be used for this purpose.**
5. The **DRILL ROD EXTRACTION TOOL** provides leverage to remove the drill rod from clays and other materials.
6. Two **CHARGER/ADAPTERS** are supplied: one for dc (12 volt negative ground systems) and one for ac.
7. The **TRANSPORT CASE** is specially fitted for safe transport of the 3440 and associated parts. The case is water-resistant, but is not watertight. In case of inclement weather, the case should be protected with some type of covering to prevent intrusion of rain, etc.
8. **OPERATOR'S MANUAL, CALIBRATION DOCUMENTS, and GAUGE CERTIFICATE**

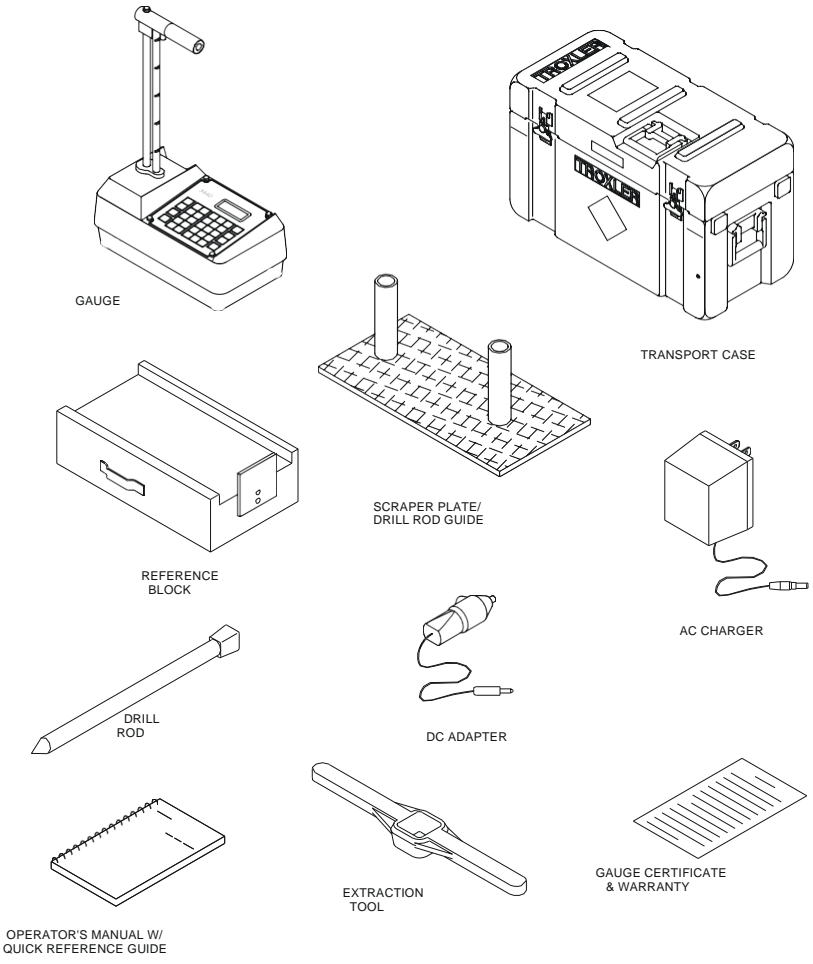

Figure 1-1. 3440 Gauge and Standard Accessories

CONTROL PANEL KEYPAD

The 3440 gauge control panel consists of two sections: the 20-key control keypad (Figure 1–2) and the **⟨ON⟩** and **⟨OFF⟩** keys. Keystrokes result in an immediate “beep” from the gauge. If the beep is not heard, the operation is not completed. Gauge and control panel operations are described throughout the manual. Table 1–1 summarizes the functions of each key, and provides page references for more information on certain operations.

The **⟨SHIFT⟩** and shift function keys are color-coded yellow for ease of identification. The **⟨SHIFT⟩** must be pressed before pressing a function key. Functions are directly addressable from any other function except the calculator mode. Pressing **⟨SHIFT⟩** causes the display’s top line to change to **–SHIFT FUNCTION–**.

NOTE

If a function key is not pressed within four seconds, the gauge reacts as if no key was pressed. If there is no action after pressing a key, the gauge will return to READY after two minutes.

The **⟨YES⟩**, **⟨NO/CE⟩**, and **⟨START/ENTER⟩** keys apply to all gauge modes. For a complete reference to any function, consult the index. Pressing **⟨START/ENTER⟩** from most modes will abort the mode and begin a test.

The calculator function keys are **⟨MS⟩**, **⟨MR⟩**, **⟨+⟩**, **⟨–⟩**, **⟨x⟩**, **⟨÷⟩**, and **⟨=⟩**.

YES EXIT	NO/CE C/CE	STATUS 7	MODE 8	SPECIAL 9
STORE MS	OFFSET MR	PROJECT 4	PRINT 5	ERASE 6
PROCTOR/ MARSHALL +	TIME -	COUNTS 1	DEPTH 2	CALC. 3
SHIFT ×	STANDARD ÷	RECALL 0	.	START/ ENTER =

Figure 1–2. 3440 Keypad Layout

Table 1–1. 3440 Keypad Functions

KEYS	DESCRIPTION	PAGE
YES EXIT	Answers display prompts. Permits exit from the calculator mode.	
NO/CE C/CE	Answers display prompts/Clear last entry. Clears calculator entry.	
STATUS 7	(SHIFT function) Displays status of gauge functions. Number key.	5–16
MODE 8	(SHIFT function) Asphalt or Soils selection. Number key.	2–6
SPECIAL 9	(SHIFT function) Provides access to special functions. Number key.	6–1
STORE MS	To store data in gauge memory. Memory store function for the calculator mode.	4–4
OFFSET MR	Select measurement offsets. Memory recall function for the calculator mode.	5–3
PROJECT 4	(SHIFT function) To enter, view, or erase a project. Number key.	2–8
PRINT 5	(SHIFT function) Download data. Number key.	5–18
ERASE 6	(SHIFT function) Erase data. Number key.	5–21
PROCTOR/ MARSHALL +	Proctor or Marshall value selection. Addition sign for calculator function.	5–13
TIME –	Select time interval for testing and measurement. Subtraction sign for calculator function.	2–5
COUNTS 1	(SHIFT function) Displays last moisture and density counts. Number key.	5–21
DEPTH 2	(SHIFT function) Selects depth mode. Number key.	5–22
CALC. 3	(SHIFT function) To access the calculator mode. Number key.	5–24
SHIFT ×	Activates all SHIFT function modes Multiplication sign for calculator mode.	
STANDARD ÷	Provides access to standard count mode. Division sign for calculator mode.	
RECALL 0	(SHIFT function) Recalls last moisture and density reading. Number key.	5–22
.	Decimal point key.	
START/ ENTER =	See manual text and index. Equals sign for calculator mode.	

CHAPTER 2

GETTING STARTED

This chapter explains how to get started with the Series 3440 Surface Moisture-Density Gauge. Functions explained include turning the gauge on, basic parameter setup and taking a *standard count*.

NOTE

It is recommended that this chapter be read and fully understood before operating the gauge for the first time.

CONTENTS

Turning the Gauge On.....	2-2
Daily Inspection.....	2-2
Basic Parameter Setup.....	2-4
Setting Measurement Units.....	2-4
Count Time Selection.....	2-5
Mode Selection.....	2-6
Selecting a Project Number.....	2-8
Setting the Clock/Calendar.....	2-11
Taking the Standard Count.....	2-13
Viewing the Last Four Standard Counts.....	2-17

TURNING THE GAUGE ON

The gauge uses rechargeable NiCad batteries (included) as a power source.

To turn the gauge on, press **<ON>**.

When first turned on, the display screen fills with test characters before proceeding to the self-test phase.

After two seconds, the gauge enters a 300-second self-test phase. During the self-test, the gauge displays the gauge model number, software version, serial number, company name, and progress (in seconds) of the test.

After the self-test, press any key to enter the *Ready* mode.

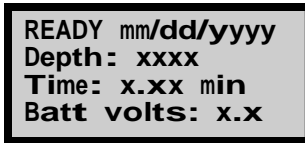

READY mm/dd/yyyy
Depth: xxxx
Time: x.xx min
Batt volts: x.x

The top line of the **READY** display alternates between the date and time. The gauge returns to the *Ready* mode when the gauge is “ready” to proceed to another function or there is no activity for more than 2 minutes.

After 5 hours of no activity, the gauge will automatically perform a total power shutdown.

DAILY INSPECTION

The gauge should be inspected daily before use to ensure proper operation of all safety features as follows:

1. Push the source rod down into the backscatter position and then raise it back to the shielded position. Turn the gauge over and verify that the tungsten sliding block is completely shut. If the gauge base opening is not completely closed by the sliding block, clean the sliding block and verify proper operation before using, transporting, or storing the gauge. Refer to the *Cleaning the Tungsten Sliding Block* section on page F-4 for cleaning instructions.



WARNING

Do not store or transport the gauge unless the tungsten sliding block is completely closed. Increased radiation levels may violate transportation regulations, and may cause excessive personnel radiation exposure.

2. If a radiation survey instrument is available, verify that the radioactive gamma source is in place by measuring the exposure rate at the surface of the gauge. The exposure rate should be approximately 10-20 mrem per hour. A reading of about 1 mrem or less indicates that either the survey instrument is not working or the cesium-137 (Cs-137) source may be missing. Refer to the *Troubleshooting* information in Appendix F for further instructions.

BASIC PARAMETER SETUP

SETTING MEASUREMENT UNITS

Before taking measurements, the operator should determine the *unit of measurement* that is required for screen displays and/or printouts. The available selections are *Metric* and *PCF*.

To execute the *Set Units* function, press **<SHIFT>** and **<SPECIAL>** for:

SPECIAL FUNCTION
YES- Next menu
1- STAT TEST
2- DRIFT TEST

Press **<YES>** three times for the display:

YES- Next menu
9- SET UNITS
10- BAUD RATE
11- COMM PROTOCOL

Press **<9>** for the display:

UNITS in PCF
Press: 1-PCF
2-METRIC
ENTER- No change

or the display will be:

UNITS in METRIC
Press: 1-PCF
2-METRIC
ENTER- No change

Press either **<1>** or **<2>** for the required units.

The gauge will remain in the selected mode until reset.

COUNT TIME SELECTION

The 3440 gauge provides three different count times to be used for taking readings. The longest count time, four minutes, will usually provide the highest accuracy. If a quick reading is required, one of the shorter periods may be selected.

Press **<TIME>** for the display:

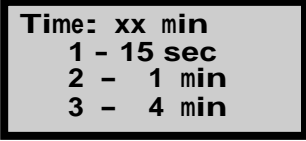

Time: xx min
1 - 15 sec
2 - 1 min
3 - 4 min

For example, assume that a count time of 1 minute is desired. Press **<2>** for the display:

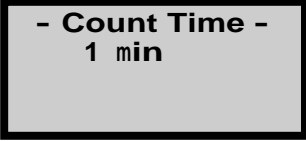

- Count Time -
1 min

The display will return to **READY**.

MODE SELECTION

The *Mode* function provides for the selection of *Soil* or *Asphalt* mode.

Under *Asphalt* mode, the sub-mode selection of % *Marshall* or % *Voids* may be enabled.

Also, while in *Asphalt* mode, the % *Voidless* density selection may be enabled.

To select the *Mode* function, press **<SHIFT>** and **<MODE>** for the display:

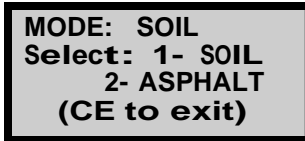

MODE: SOIL
Select: 1- SOIL
2- ASPHALT
(CE to exit)

Soil Mode Selection

From the above display, press **<1>** to select *Soil* mode. The display is:



SOIL MODE

After a short delay, the display will return to **READY**. Chapter 4 provides instructions for taking measurements in *Soil* mode.

Asphalt Mode Selection

From the first display on this page, press **<2>** to select *Asphalt* mode.

The display will be:

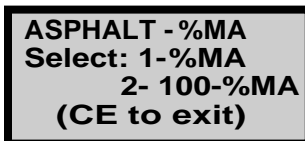

ASPHALT - %MA
Select: 1-%MA
2- 100-%MA
(CE to exit)

ASPHALT MODE, % MARSHALL. If % *Marshall* (or % compaction compared to a Marshall target) is required, press **<1>** from the last display on page 2–6.

$$\% \text{ Marshall} = (WD/\text{Marshall}) \times 100$$

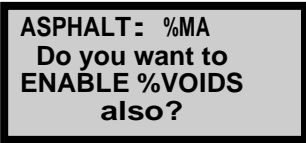

ASPHALT: %MA
Do you want to
ENABLE %VOIDS
also?

To enable % *Voids*, press **<YES>**.

$$\% \text{ VOIDS} = 100 \times [1 - (WD/\text{Voidless})]$$

NOTE

For the gauge to calculate % *Voids*, a *voidless density* must be entered into the gauge as described on page 5–15. The voidless density is the maximum theoretical density, or Rice test result.



ASPHALT: %MA
%VOIDS

After a brief delay, the screen display returns to the **READY** display.

ASPHALT MODE, 100 – %MA. If $100 - \%MA$ is required, press **<2>** from the last display on page 2–6.

NOTE

The term % *Voids* is defined as $100 - \%Voidless$.

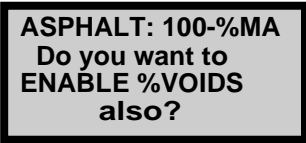

ASPHALT: 100-%MA
Do you want to
ENABLE %VOIDS
also?

$$100 - \%MA = 100 \times [1 - (WD/\text{Marshall})]$$

To enable % *Voids*, press **<YES>**.

$$\% \text{ VOIDS} = 100 \times [1 - (WD/\text{Voidless})]$$

After a short delay, the display returns to **READY**. Chapter 4 provides instructions for taking measurements in *Asphalt* mode.

SELECTING A PROJECT NUMBER

The *Project* function allows unique alphanumeric project numbers to be input into gauge memory. All subsequent readings for a project are stored under its project number.

NOTE

Only one project number can be current in the gauge at any one time. Other stored projects may be recalled at any time.

To select the *Project* function, press **<SHIFT>** and **<PROJECT>** for the display:

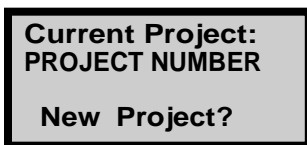

**Current Project:
PROJECT NUMBER**

New Project?

Make an Existing Project Number Current

To make an existing project current, press **<YES>** to display:

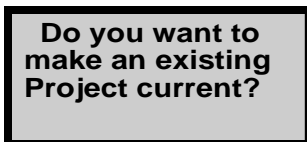

**Do you want to
make an existing
Project current?**

Press **<YES>** to display:

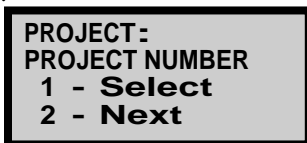

**PROJECT:
PROJECT NUMBER**

1 - Select

2 - Next

Press **<1>** to select the displayed project, or **<2>** to display the next project name.

Enter a New Project Number

To enter a new project number, press **<YES>** at the first display on the previous page.

**Do you want to
make an existing
Project current?**

Press **<NO/CE>** to display:

**Input PR:
— Press SHIFT FOR
LETTERS (ENTER)**

The project number may contain both numeric and alphabetic characters. For each numeric character, press the desired number key.

For alphabetic characters, press **<SHIFT>** to display:

**Input PR:
A
SHIFT— See chars
YES— Select**

Press **<SHIFT>** until the desired character is displayed, then press **<YES>** to accept the character. When the complete project number is displayed, press **<START/ENTER>** to activate the project number and exit.

View Old Project Data

To view data for an old project, from the first display on the previous page, press **<NO/CE>** to display:

**Do you want to
view and/or
erase a Project?**

Press **<YES>** to display:

PROJECT NUMBER
1 - View
2 - Erase
3 - Next

Press **<3>** (if required) until the desired project number is displayed, then press **<1>** to display:

PROJECT NUMBER

mm/dd/yyyy
(Press SHIFT)

Press **<SHIFT>** to view the data for the displayed project number.

Erase Old Project Number

To erase an old project number, from the first display under the *View Old Project Data* section on the previous page, press **<NO/CE>** to display:

**Do you want to
view and/or
erase a Project?**

Press **<YES>** to display:

PROJECT NUMBER
1 - View
2 - Erase
3 - Next

Press **<3>** (if required) until the desired project number is displayed, then press **<2>** to display:

Project:
PROJECT NUMBER

SHIFT/YES= ERASE

Press **<SHIFT>** and **<YES>** to *erase* the project number shown on the display.

SETTING THE CLOCK/CALENDAR

The *Time/Date* function allows the operator to change the current time-of-day or date that is displayed on the screen and used for measurement reports.

To execute the *Time/Date* function, press **<SHIFT>** and **<SPECIAL>** for:

SPECIAL FUNCTION
YES- Next menu
1- STAT TEST
2- DRIFT TEST

Press **<19>** to display:

EXTENDED
FUNCTIONS
Enter Code----
and Press ENTER

The *Access Code* must be entered. This code is for authorized personnel only. If you need assistance with the code, contact your nearest Troxler Representative.

Enter the code and press **<START/ENTER>**. The display will be:

YES- Next menu
1- Time/Date
2- Customer Name
3- Serial Number

Press **<1>** to select the *Time/Date* function. The display will be:

Current Date:
mm/dd/yyyy
Do you want to
change Date?

Press **<YES>** to change the current date. The display is:

Current Date:
mm/dd/yyyy
Input Date
and press ENTER

Input the new date and press **⟨START/ENTER⟩**.

NOTE

Leading zeros must be entered for any single-digit day or month. For example, the date *June 9, 2000* must be entered as **⟨0⟩⟨6⟩⟨0⟩⟨9⟩⟨2⟩⟨0⟩⟨0⟩⟨0⟩.**

After pressing **⟨START/ENTER⟩**, the display will be:

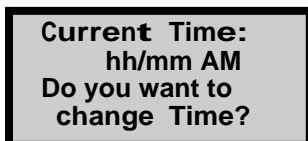

**Current Time:
hh/mm AM
Do you want to
change Time?**

If the time of day is to be changed, press **⟨YES⟩**. The display is:

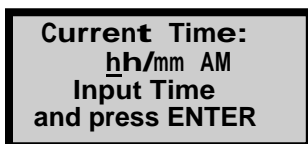

**Current Time:
h^uh/mm AM
Input Time
and press ENTER**

Input the new time and press **⟨START/ENTER⟩**. Again, note that the *leading* zeros must be entered for any single digit hour or minute. For example, *7:06* must be entered as **⟨0⟩⟨7⟩⟨0⟩⟨6⟩**.

After pressing **⟨START/ENTER⟩**, the display will be

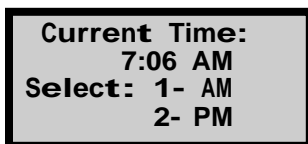

**Current Time:
7:06 AM
Select: 1- AM
2- PM**

Select either **⟨1⟩** (for *AM*) or **⟨2⟩** (for *PM*).

After a few seconds, the display will return to the *Extended Functions* menu.

TAKING THE STANDARD COUNT

The front of the 3440 gauge is closest to you when the gauge is placed with the source rod to the left and the control panel to the right, as shown in Figure 2–1. The handle contains the indexer trigger mechanism, used to position the source rod on the notched index rod.



NOTE

The source rod should always be in the SAFE position when the gauge is not in use.



NOTE

All Troxler nuclear gauges use low-level radioactive sources for taking measurements. The sources in the 3440 gauge have a half-life of 30 years (cesium-137) and 432 years (americium 241:beryllium). In other words, the amount of radioactivity from the cesium source will be reduced by one-half (1/2) in 30 years. Because of this continual decay, the *standard count* is taken to re-adjust the gauge to compensate for the decay. This decay is a known occurrence and will not compromise the accuracy of the gauge as long as the standard counts are taken. It is important to take the standard count when a gauge is initially received from the factory and before taking measurements at the worksite.

The gauge should be turned ON before leaving for the worksite. This allows the gauge to complete its self-test routine while in transit. The standard count set can then be taken upon arrival at the work site without any delays. The gauge automatically compares the new density and moisture standard counts to the average of the values from the last four standard counts. The new standard count will “pass” if the density standard count is within 1% of the density average and the moisture standard count is within 2% of the moisture average. After taking the standard count, be sure to enter it in the log.

To take a standard count, place the reference standard block on a flat surface at least 6 ft (2 m) from any vehicle or structure, and a minimum of 30 ft (10 m) from any other radioactive source. The surface can be asphalt or concrete pavement, compacted aggregate or a similar surface with density not less than 100 pcf (1600 kg/m³). Do not use truck beds, tailgates, tabletops, and so on.

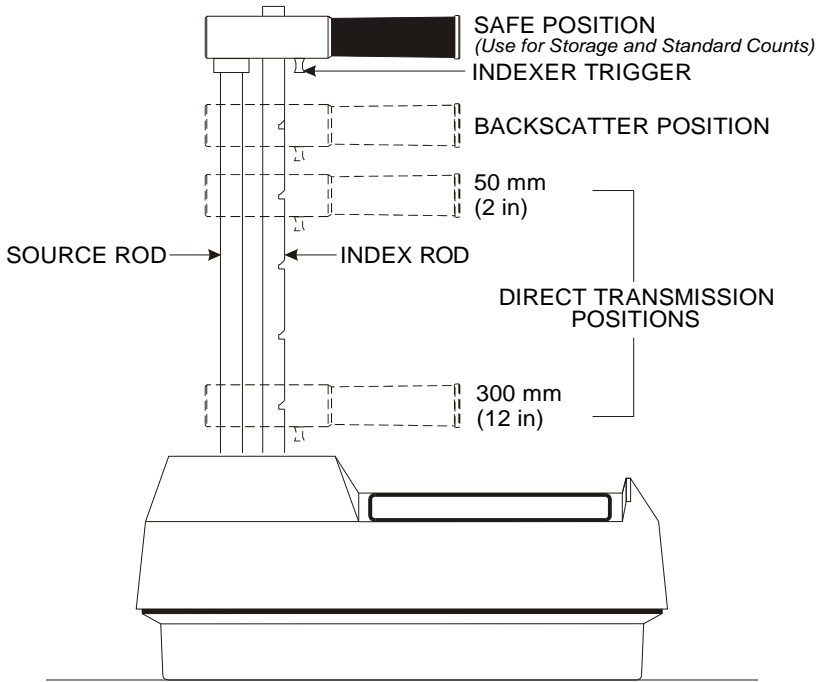

Figure 2–1. 3440 Gauge Showing Rod Positions

Place the gauge on the reference standard block as shown in Figure 2–2, making sure the block top and gauge base are clean and smooth, with no soil or other material to prevent good surface-to-surface contact. The gauge must be positioned between the raised edges of the block and with the right side of the gauge firmly seated against the metal butt plate on the block.

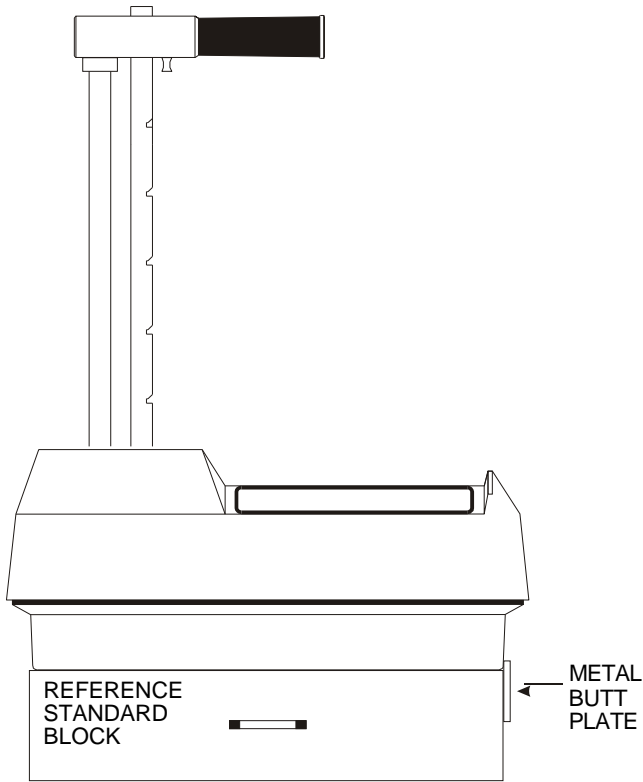

Figure 2-2. Gauge Position on Reference Standard Block

To begin taking a standard count, press **<STANDARD>** for the display:

```
-Standard Count-  
DS= xxxx  
MS= xxxx  
Take new count?
```

Press **<YES>** for the display:

```
Is gauge on Std-  
Block & Source  
rod in SAFE pos?
```

Make sure the gauge is on the reference standard block as shown in Figure 2–2. Ensure that the source rod in the **SAFE** position and press **<YES>** to begin taking the four-minute standard count.

**Taking
Standard Count
xxx seconds
remaining**

After count completion, the display is:

**MS=xxxx xx.xx %P
DS=xxxx xx.xx %P
Do you want to
use the new STD?**

The *P* indicated to the right of the percentage figures indicates that the new counts are within the 1% density and 2% moisture limits. If the percentages are not within these limits, an *F* will be displayed. If you do get an *F*, or fail, display check for the following conditions:

- ✓ Is the source rod in the proper position?
- ✓ Are any other gauges close by?
- ✓ Is the gauge seated correctly on the reference standard block?
- ✓ Are the base of the gauge and the top of the reference standard block both clean?
- ✓ Is the reference standard block on a recommended surface?

If all other conditions are normal, do not accept the standard count just taken. Press **<NO/CE>** and take *another* standard count.

NOTE

If the second count also fails, the old standard count sets should be erased as described on page 7–9. Successive standard count failures are usually the result of a prolonged period between the last standard count and the new one. This causes the tolerance to be exceeded because of source decay. After the old standard counts are erased, four new standard counts should be taken.

Press **<YES>** to accept the new standard count and enter it into memory. If **<NO/CE>** is pressed, the new count is not accepted and the display returns to show the old values.

VIEWING THE LAST FOUR STANDARD COUNTS

To view the last four standard counts, press **(STANDARD)** for the display:

```
-Standard Count-  
DS= xxxx  
MS= xxxx  
Take new count?
```

Press **(NO/CE)** for the display:

```
-Standard Count-  
Want to view  
last four  
Standard Counts?
```

Press **(YES)** for the display:

```
Density Std Cts  
1:xxxx 2:xxxx  
3:xxxx 4:xxxx  
(Yes for Moist.)
```

To view the moisture standard counts, press **(YES)**. The display will be:

```
Moist. Std Cts  
1:xxxx 2: xxxx  
3:xxxx 4: xxxx  
(Press any key)
```

The *View Standard Count* function may be exited by pressing any key.

NOTES

CHAPTER 3

MEASUREMENT SITE PREPARATION

This chapter covers the basic steps required to properly prepare a soil, base, or asphalt surface for measurement.

CONTENTS

Soil and Base Course Preparation3-2

Asphalt Surface Preparation3-4

SOIL AND BASE COURSE PREPARATION

Surface conditions for the test are critical to gauge performance and test results. The scraper plate can be used to prepare surfaces that are not smooth. Any small valleys, holes, or voids in surfaces can be filled with sand or fine material from areas near the test site. Filling of large areas on test surfaces should be avoided.

Placing the scraper plate on the surface to be tested, move the plate back and forth in a small area to smooth the test site. Lift the plate to fill any small depressions or voids present. Place scraper plate on the surface again and press down slightly to level the surface.



WARNING

Wear safety glasses while hammering drill rod through scraper plate.

Put the drill rod through the extraction tool and then through one of the guides on the scraper plate (see Figure 3-1). Wearing safety glasses, step on the scraper plate to hold it firmly and hammer the drill rod at least, *but not limited to*, 2 in. (50mm) deeper than the desired test depth. The drill rod increment markings include the additional 2-inch depth needed for rod clearance. Before removing the drill rod from the scraper plate, mark the test area as shown in Figure 3-2 to make it easier to position the gauge over the site.

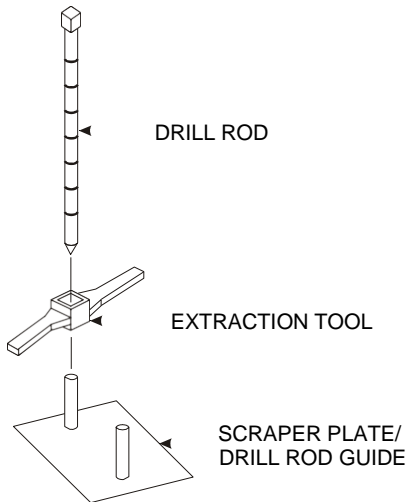

Figure 3-1. Drill Rod and Extraction Tool with Scraper Plate

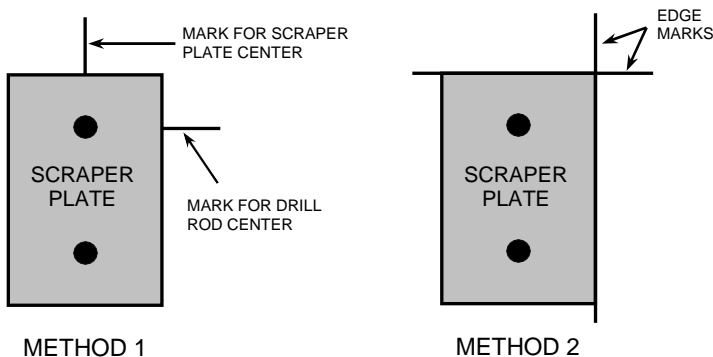

Figure 3–2. Marking the Test Area

Remove the drill rod by pulling straight up and twisting the extraction tool. Do not loosen the drill rod by tapping from side to side with the hammer. This will distort the hole or cause loose material to fill the 2-inch gap from the bottom of the hole. Carefully pick up the scraper plate and set it aside. Place the gauge on the surface prepared by the scraper plate so the source rod can enter the hole without disturbing any loose material around it.



CAUTION

DO NOT use the source rod of the Model 3440 gauge to drill holes.

Using the handle and trigger mechanism, lower the source rod into the hole. Release the trigger at the desired depth and listen for the “click,” indicating that the source rod is properly locked into position on the index rod. Lightly press the top of the handle to confirm positive source rod locking. Gently pull the gauge to the right until the source rod is firmly in contact with the side of the hole.

ASPHALT SURFACE PREPARATION

Test site selection for asphalt surfaces is much the same as soils except that preparation differs slightly. Voids may be filled on coarse, open-graded mixes using soft sand or cement powder, taking care to fill only the voids and leaving the asphalt bare for surface contact with the gauge base. The base should be resting on the asphalt and not on the fill material.

Try to “rock” the gauge – if you can “rock” it, place more fill material or move the gauge to a flatter surface to correct the problem; the gauge should not rock. Put the source rod in backscatter position, making sure the rod is in the proper index rod notch and not resting on the asphalt.

CHAPTER 4

TAKING A DENSITY/MOISTURE MEASUREMENT

This chapter covers the basic steps required for taking and storing actual density and/or moisture measurements with the Series 3440 Surface Moisture-Density Gauge.

CONTENTS

Taking a Reading	4-2
Soil Mode.....	4-2
Asphalt Mode.....	4-3
Storing a Reading.....	4-4
Storage – Asphalt Mode (Auto-Station Enabled).....	4-4
Storage – Asphalt Mode (Auto-Station Disabled).....	4-5
Storage – Soil Mode.....	4-6

TAKING A READING



NOTE

When not taking readings, always keep the source rod in the **SAFE** position. For added operator safety, the source rod on the 3440 gauge automatically retracts to the **SAFE** position when the gauge is picked up by the handle.

If you do not hear a “click” when the source rod is raised to the **SAFE** position, look at the bottom of the gauge to verify that the tungsten sliding block is completely closed. If the gauge base opening is not completely closed by the sliding block, the sliding block may require cleaning. Refer to the *Cleaning the Tungsten Sliding Block* section on page F-4 for cleaning instructions.



CAUTION

Do not store or transport the gauge unless the tungsten sliding block is completely closed. Increased radiation levels may violate transportation regulations, and may cause excessive personnel exposure.

SOIL MODE

Enable the *Soil* mode prior to taking a measurement. Refer to Chapter 2 for more details on gauge setup.

Ensure that the site to be measured has been properly prepared. Refer to Chapter 3 for more detail in site preparation. Position the gauge at the proper location and release the source rod, pushing it to the proper depth.

Check to see that all parameters have been set to the correct values.

To start the measurement, press **(START/ENTER)** for the display:

```
Depth: xx
PR: xxxx

Time: xx  sec.
```

After the gauge completes its count time, the display will be:

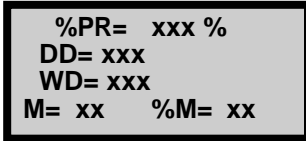

```
%PR= xxx %  
DD= xxx  
WD= xxx  
M= xx    %M= xx
```

The reading may be stored for later use by pressing the **(STORE)** key. Refer to page 4-4.

ASPHALT MODE

Enable the *Asphalt* mode prior to taking a measurement. Refer to Chapter 2 for more details on gauge setup.

Ensure that the asphalt surface has been properly prepared. Refer to Chapter 3 for more detail in site preparation. Place the gauge at the proper location and move the source rod to the backscatter position (refer to Figure 2-1 on page 2-14).

NOTE

In some applications, the source rod may be extended to place the gauge in a *Direct Transmission* mode for use on soft asphalt.

Verify that all parameters have been set to the correct values.

Start a measurement by pressing **(START/ENTER)**. The display will be:

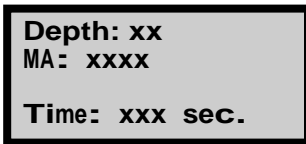

```
Depth: xx  
MA: xxxx  
  
Time: xxx sec.
```

After the gauge completes its count time, the display will be:

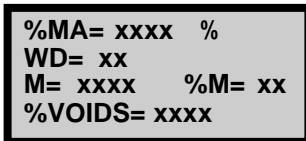

```
%MA= xxxx %  
WD= xx  
M= xxxx    %M= xx  
%VOIDS= xxxx
```

The above display will remain until a function key is pressed, a new measurement is taken, the **(NO/CE)** key is pressed, or the gauge shuts off due to inactivity.

The reading may be stored for later use by pressing the **(STORE)** key. Refer to page 4-4.

STORING A READING

The 3440 gauge allows the operator to store measurements under specific project numbers and station numbers for later recall. This function will work in soil mode as well as in asphalt mode. The 3440 will provide for additional numeric data storage under the station number and project. The operator can also setup the gauge to prompt for the information required on U.S. Federal Highway Administration (FHWA) projects (see page 6–31).

The 3440 gauge is equipped with an *Auto-Station* function that allows automatic indexing of the station numbers. See page 6–11 for more information on using this function.

To store readings, take a measurement following the procedure discussed on pages 4–2 and 4–3. When the density and/or moisture results are displayed, the reading may be stored.

STORAGE – ASPHALT MODE (AUTO-STATION ENABLED)

Press **<STORE>**.

If the *Auto-Station* function is enabled, the display will be:

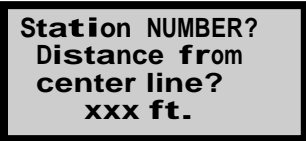

**Station NUMBER?
Distance from
center line?
xxx ft.**

From the above screen, input the distance from the centerline and press **<START/ENTER>** for the display:



**Left or right
of center line?
1- LEFT
2- RIGHT**

Pressing **<1>** or **<2>** yields:

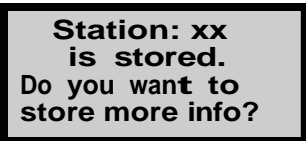

**Station: xx
is stored.
Do you want to
store more info?**

If **<YES>** then:

Station:
1-----
Input and
Press ENTER

If **<NO/CE>** then:

Station: xx
Reading is
stored.

The **READY** screen is then displayed.

STORAGE – ASPHALT MODE (AUTO-STATION DISABLED)

If the *Auto-Station* function is disabled, the display will be:

Station NUMBER?
Press ENTER when
completed.

Press **<START/ENTER>** for:

Station: xx
Distance from
center line?
xxx ft.

Enter the number of the station and press **<START/ENTER>**.

Left or right
of center line?
1- LEFT
2- RIGHT

Choose <1> or <2>:

**Station: xx
is stored.
Do you want
store more info?**

If <YES>:

**Station:
1-----
Input and
Press ENTER**

Repeat loop until additional data is complete.

If <NO/CE>:

**Station: xx

Reading is
stored.**

The **READY** screen is then displayed.

STORAGE – SOIL MODE

Press <STORE>.

**Station NUMBER?

Press ENTER when
completed.**

Press <START/ENTER> for:

**Station: xx
is stored.
Do you want
store more info?**

If **<YES>**:

Station:
1 -----
Input and
Press ENTER

Repeat loop until additional data is complete.

If not, press **<NO/CE>**. The **READY** screen is then displayed.

NOTES

3440 OPERATIONS

This chapter contains descriptions and instructions for functions and procedures used frequently by most gauge operators on a day-to-day basis. In many cases, these operations will be performed every time a measurement is taken. Therefore, this chapter should be reviewed and completely understood before taking measurements in the field. Several of these functions have been described earlier in this manual.

CONTENTS

Offsetting a Reading	5-3
Offsets – Wet Density	5-4
Offsets – Moisture.....	5-5
Offsets – Trench.....	5-10
Count Time Function	5-12
Store Function	5-12
Proctor/Marshall/Voidless Function.....	5-13
Recall a Stored Proctor/Marshall Value.....	5-14
Enter a New Proctor/Marshall Value	5-14
Voidless Density Value.....	5-15
Status Function.....	5-16
Mode Function	5-17
Project Function	5-17
Print Function.....	5-18
Printing a Single Project.....	5-19
Erase Function.....	5-21
Counts Function	5-21

CONTENTS (Continued)

- Recall Function5-22

- Depth Function.....5-22
 - Manual Mode.....5-22
 - Automatic Mode5-23

- Calculator Function.....5-24
 - Addition5-24
 - Subtraction.....5-25
 - Division.....5-25
 - Multiplication.....5-25
 - Chain Calculations5-25
 - Memory Storage Arithmetic5-25

OFFSETTING A READING

The Troxler 3440 Gauge is factory calibrated for soils, asphalt, and concrete. The operator can adjust gauge readings based on other performance test, such as control strip results, core samples, or sand cones. This adjustment, or shift, is known as an *offset*.

NOTE

When an offset has been enabled, all future readings will automatically be adjusted with the offset factor *regardless of the test site*. It is very important that the operator *DISABLE* the offset function prior to taking readings on materials that do not require an offset. Offset functions will be disabled if the gauge is turned off for more than 10 seconds.

The 3440 gauge provides offsets for the following measurement types:

- ◆ Wet density measurements
- ◆ Moisture measurements
- ◆ Trench measurements

Offsets may be required for an accurate measurement if the material to be measured meets any of the following conditions:

- ◆ Has a density outside the range of 70 to 170 pcf (1100 to 2700 kg/m³)
- ◆ Has a high concentration of elements with atomic numbers greater than 20 (such as concrete, some coals, or ferrous soils)
- ◆ Is high in a *hydrogen*-rich material (such as gypsum, coal, or lime).

The 3440 gauge also requires an offset if measurements are to be taken inside a trench or close to a structure. The walls of the trench or structure may scatter the gamma photons and neutrons back to the gauge, resulting in inaccurate density or moisture readings.

To enable the *Offset* function, press **<OFFSET>** to display:

-OFFSET-	Select:
1-Dens.	-OFF-
2-Moist.	-OFF-
3-Trench	-OFF-

OFFSETS – WET DENSITY

To enable a *wet density offset*, press **<1>** from the display on the previous page.

The display will be:



**Density Offset
DISABLED
Do you want to
ENABLE?**

Press **<YES>** to display:

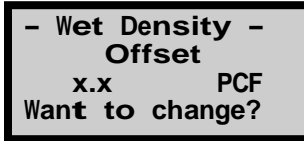

**- Wet Density -
Offset
x.x PCF
Want to change?**

To change the offset, press **<YES>** (pressing **<NO/CE>** leaves the factors unchanged).

The display is:

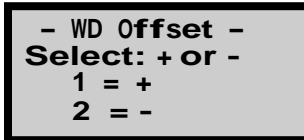

**- WD Offset -
Select: + or -
1 = +
2 = -**

Select either **<1>** or **<2>** for the display:

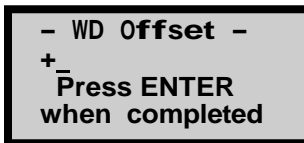

**- WD Offset -
+_
Press ENTER
when completed**

Use the *numbered* keys to enter a new offset factor. When the entire value is input, press **<START/ENTER>** for the display:



**Density Offset
ENABLED!**

The offset will be stored and the gauge returns to **READY**.

OFFSETS – MOISTURE

Moisture offsets (plus or minus) are sometimes needed when testing certain materials that contain high amounts of *hydrogen*-rich compounds, since the 3440 measures moisture by determining the amount of hydrogen present in the material. Some hydrogen-rich materials are gypsum, coal, lime, fly ash, organic material, mica clays, and phosphates. If the material contains compounds that are high in hydrogen forms other than water, an inaccurate reading may result. Offset factors for these measurements would be a minus value.

In rare cases, the material to be measured may contain significant amounts of *neutron absorbers* such as boron or cadmium. These elements will result in a moisture reading that is lower than the actual value. In these cases, the offset factor will be a plus value.

To enable a moisture offset, press **<2>** from the display on page 5-3.

The display will be:

**Moisture Offset
DISABLED
Do you want to
ENABLE?**

Press **<YES>** for the display:

**Moisture Offset-
K=x.xx
Do you want a
new M-Offset?**

To change the moisture offset, press **<YES>** (pressing **<NO/CE>** leaves the factors unchanged.)

The display is:

**Select source
of Offset:
1- gauge derived
2- stored value**

The operator may then select a previously stored offset value or a gauge-derived value. The gauge-derived value may be a new value input via the keypad or an actual value recorded from a measurement.

Moisture Offset – Gauge Derived

From the last display on the previous page, select **<1>** for the display:

Select:
1- True M x.x % 2-
Gauge M x.x %
ENTER to enable

For a true gauge-derived offset, two values must be input: the *true moisture* value, which is determined by laboratory analysis, and the *gauge moisture*, which is the gauge reading on the material to be tested.

If the above values are correct, press **<START/ENTER>**.

To input a new true moisture value, press **<1>** for the display:

True Moisture-
x.x %
Press ENTER
when completed

Input the laboratory value and press **<START/ENTER>**.

To input a new gauge moisture value, press **<2>** for the display:

Gauge Moisture-
Select:
1- Keypad entry
2- Measurement

KEYPAD ENTRY. To use the keypad to enter the gauge moisture reading from a previous test, press **<1>**. The display is:

Gauge Moisture-
x.x %
Press ENTER
when completed

Input the gauge moisture via the keypad and press **⟨START/ENTER⟩**.

```

SELECT:
1- True M x x % 2-
  K=x.xx
Do you want
to save this value
or later use?
  
```

Press **⟨START/ENTER⟩**.

- ▶ To enable the K value and store it in memory for later use, press **⟨YES⟩**:

```

Enter desired
Memory location
of M-Offset:
(1-4) _
  
```

Enter the appropriate value (1-4) and press **⟨START/ENTER⟩**:

```

Moisture Offset
SAVED
K=x.xx
location x
  
```

```

Moisture Offset
ENABLED
K=x.xx
  
```

- ▶ To enable the K value, but not store it in memory, press **⟨NO/CE⟩**. The value will be enabled, but will not be saved after it is disabled or the gauge is turned off.

```

Moisture Offset
ENABLED
K=x.xx
  
```

The offset will be enabled, but will not be saved after it is disabled or the gauge is turned off. The display will then return to **READY**.

GAUGE MEASUREMENT. If the gauge is to be used to automatically record the moisture value, press **(2)** from the third screen on page 5–6. The display is:

**Place gauge on
surface to test.
Press START for
(4) 1 min counts**

Place the gauge in the backscatter position **ONLY** at the location to be tested. Press **(START/ENTER)**. The display will be:

**Moisture Count
#1
Moist. count #1
MC =xxxx
Press ENTER for
next count**

After counting down to zero, the display will be:

Position the gauge at the next test site and press **(START/ENTER)**. Repeat these steps for tests 3 and 4. After test 4 is completed, the display will be:

**Gauge Moisture–
Old:x.xx %
New:x.xx %
(ENTER to save)**

Press **(START/ENTER)** to save the new value. The display is:

**K=x.xx
Do you want to
save this value
or later use?**

- ▶ To enable the *K* value but not save it for future use, press **(NO/CE)**. The value will be enabled, but will not be saved after it is disabled or the gauge is turned off. The display will return to **READY**.

- To enable the *K* value and store it in memory for later use, press **⟨YES⟩**. The display will be:

**Enter desired
Memory location**
**Moisture Offset
SAVED**
K=x.xx
location x

Enter the appropriate value (1-4) and press **⟨START/ENTER⟩**:

After a short delay, the display is:

**Moisture Offset
ENABLED**
K=x.xx

The offset will be enabled and the display will return to **READY**.

Moisture Offset - Stored Value

To recall a previously stored moisture offset, press **⟨2⟩** from the last display on page 5-5.

The display will be:

**Enter desired
Memory location
of M-Offset:
(1-4) _**

Enter the appropriate value (1-4) and press **⟨START/ENTER⟩**:

**Moisture Offset
ENABLED**
K=x.xx

The offset will be enabled and the display will return to **READY**.

OFFSETS – TRENCH

Vertical structures such as the walls of a building, trench, or ditch often “echo” gamma photons and neutrons back to the gauge. This “echoing” may adversely affect density and moisture measurements. *Trench offsets* compensate for the influence of vertical structures on measurements.

Use a trench offset if taking a measurement inside a trench or within 2 ft (0.6 m) of a large vertical structure. When used, the trench offset adjusts all moisture measurements, but only the density measurements from backscatter through 4 in. (10 cm).

To perform a trench offset:

- ✓ As described on page 2–13, take the daily standard count *outside the trench* and record the moisture and density count values.
- ✓ Place the reference standard block and gauge in the trench. Position the gauge on top of the reference standard block as in Figure 5–1. Take a one-minute count using the *Trench Offset* mode as follows.

NOTE

During the one-minute count, the gauge must be the same distance from the wall as it will be during the anticipated test readings.

- ✓ Press **<3>** from the display on page 5–3.



- ✓ Press **<YES>** to perform the trench offset.
- ✓ Press **<YES>** to perform a new offset. Press **<NO/CE>** to use the existing offset constants. If a new offset is to be performed, the display will be:



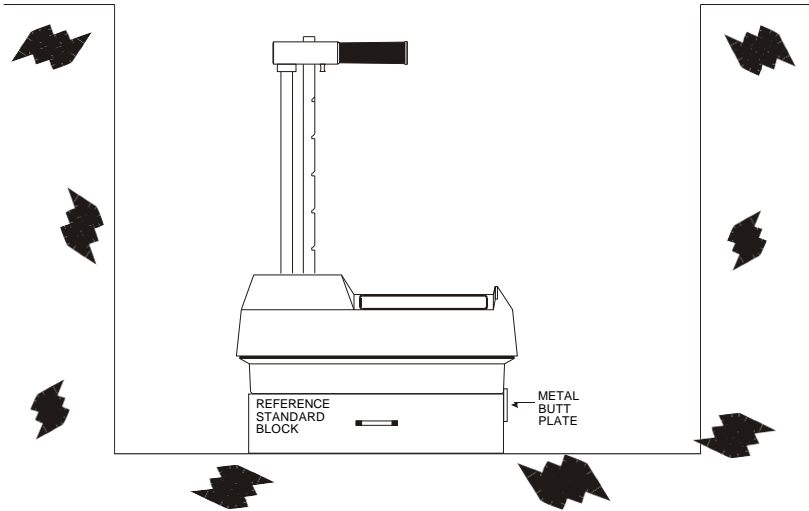

Figure 5-1. Gauge and Reference Standard Block Position for Trench Offset

- ✓ Place the gauge on the reference standard block in the trench with the source rod in the **SAFE** position.
- ✓ Begin the one-minute count by pressing **<START/ENTER>**.
- ✓ The density and moisture trench offset constants will be calculated, enabled and stored. If the gauge is not to be used for trench measurements immediately, *disable* the offset.
- ✓ To enable or disable an offset, press **<3>** from the display on page 5-3. Using the numeric keys, select the offset for enabling/disabling. The gauge will display the status of the offset and inquire if the operator wishes to change the status. Answer the inquiry by pressing either **<YES>** or **<NO/CE>**. The gauge will enable/disable the offset and return to the **READY** display.

COUNT TIME FUNCTION

The 3440 gauge provides three different count times to be used for taking measurements. The *Count Time* function is described on page 2-5.

STORE FUNCTION

The 3440 gauge allows the operator to store measurements under specific project numbers and station numbers for later recall. The *Store* function is described on page 4-4.

PROCTOR/MARSHALL/VOIDLESS FUNCTION

The 3440 gauge provides for up to four different Proctor values, four different Marshall values, and one Voidless density value to be stored for later use. These values are used to determine percent compactions. The percent compaction calculations for *Soil* and *Asphalt* modes are as follows:

$$\text{Soil mode} \quad (DD \div PR) \times 100 = \%PR$$

$$\text{Asphalt mode} \quad (WD \div MA) \times 100 = \%MA$$

$$\text{Asphalt mode} \quad 100 - [(WD \div VD) \times 100] = \%VOIDS$$

To select or change a Proctor, Marshall, or Voidless density value, press the **(PROCTOR/MARSHALL)** key for the display:

```
MA=xxx.x   PCF
PR=xxx.x
VD=xxx.x
Want to change?
```

If not, press **(NO/CE)**. Then press **(START/ENTER)**. The screen reverts to the **READY** display.

If a value is to be enabled, or a new value added or changed, press **(YES)**. The display is:

```
Select:
  1 - MA
  2 - PR
  3 - Voidless
```

NOTE

After selecting Marshall (*MA*) or Proctor (*PR*) from the above display, the steps for the selecting the Marshall and Proctor values are identical. Therefore, this manual illustrates only the Marshall value selection screens.

To change a Marshall value, press **(1)** to display:

```
Select source of
Marshall value:
1- Stored value
2- New value
```

RECALL A STORED PROCTOR/MARSHALL VALUE

To enable a previously stored value, press **<1>**. The display is:

**Select desired
Marshall:**
1:x.x 2:x.x
3:x.x 4:x.x

Select the desired Marshall value by pressing **<1>**, **<2>**, **<3>**, or **<4>** for the display:

Marshall:
x.x PCF
ENABLED!

The screen reverts to the **READY** display.

ENTER A NEW PROCTOR/MARSHALL VALUE

From the third display on page 5–13, press **<2>**. The display will be:

Marshall:
x.x PCF
Press ENTER
when completed

Enter the new value and press **<START/ENTER>**, for the display:

MA=x.x PCF
Do you want to
save this value
for later use?

Press **<YES>** to save the new Marshall value in a memory cell, for later use.

**Select Marshall
Memory cell:**
1:x.x 2:x.x
3:x.x 4:x.x

Press **<1>**, **<2>**, **<3>**, or **<4>** to select the desired Marshall memory cell:

MARSHALL
x.x PCF
ENABLED!
stored in cell x

VOIDLESS DENSITY VALUE

From the second display on the page 5-13, press **<3>** for the display:

Voidless Density
xxx.x PCF
Press ENTER
when complete.

Input the *Voidless Density* value and press **<START/ENTER>**. The screen returns to the **READY** display.

STATUS FUNCTION

The *Status* function lets the operator check all gauge settings without executing the particular function. Press **<SHIFT>** and **<STATUS>** for the display:

**-CONTROL STATUS-
Press YES to
view settings.
(CE to exit)**

Press **<YES>** to display:

**UNITS: xxx
TIME: xxxx
MODE: xxxx
(Press YES)**

Press **<YES>** to display:

**MA=x.x PCF
PR=xxx.x PCF
VD=xxx.x PCF
(Press YES)**

Press **<YES>** to display:

**D OFF: x.x
TRUE %M=x.x %
GAUGE %M=x.x %
(Press YES)**

Press **<YES>** to display:

**AUTO-STATION:OFF

(Press YES)**

Press **<YES>** to display:

**Target Prec.-

(Press YES)**

Press **<YES>** to display:

**Depth- xxxx
Calib- xxxx

(Press YES)**

Press **<YES>** to return to the first status display. Press **<NO/CE>** to return to the **READY** display.

MODE FUNCTION

The *Mode* function provides for the selection of *Soil* or *Asphalt* mode. This function is described on page 2–6.

PROJECT FUNCTION

The *Project* function allows unique alphanumeric project numbers to be input into gauge memory. All subsequent readings for a project are stored under its project number. The *Project* function is described on page 2–8.

PRINT FUNCTION

The *Print* function allows stored project data to be downloaded to a printer or computer. As shown in Figure 5-2, an RS-232 serial port on the gauge accepts a standard 25-pin “D” type interface cable connector. (To access the serial port, remove the black cover on the faceplate.) Appendix J provides instructions on using the *HyperTerminal* program in Microsoft→ Windows 95→ and later operating systems to print (upload) data to a computer.

Project data should be downloaded to a printer or computer before erasing. This provides a permanent record of the data for use later.



CAUTION
To prevent damage to the 3440 gauge, turn the gauge power off before connecting an interface cable.

Turn gauge and device off. Connect serial interface cable to gauge. Then, turn both gauge and the serial device on. Press **<SHIFT>** and **<PRINT>** to display:

Connect Serial device & Select:
1- one Project
2- all Projects

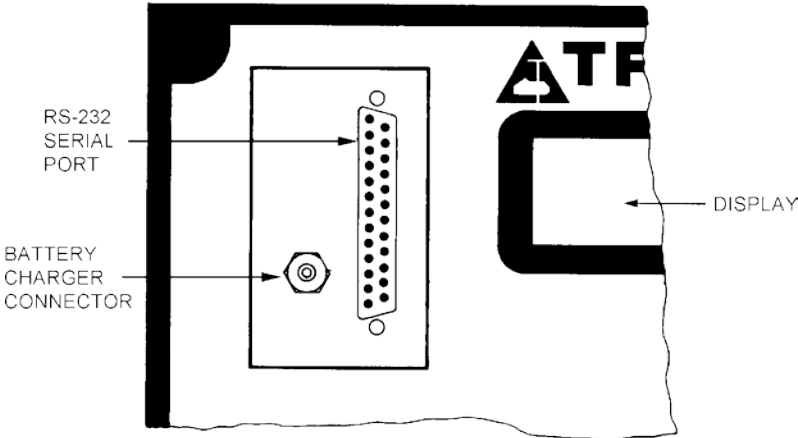

Figure 5-2. Serial Port Location

To print all project data stored in the gauge, press **(2)**. The gauge immediately begins to download all project data to the printer. Figure 5-3 shows sample project printouts. While printing, the screen displays:

**DOWNLOADING DATA
-All Projects-
Press and hold
any key to abort**

PRINTING A SINGLE PROJECT

From the first display on the previous page, press **(1)**. The display will be:

**PROJECT NUMBER
Press YES for
next Project.
ENTER to select**

Press **(YES)** to scroll through the project numbers. Press **(START/ENTER)** to print the project desired project.

**DOWNLOADING DATA
PROJECT NUMBER
Press and hold
any key to abort**

Soils Mode

```
*****
PROJECT NUMBER: 1
SN: 59441 DATE: 3/16/2000
*****
STA # 1 2:30 PM 3/16/2000
DEPTH: 4 inches
TIME: 15 seconds UNITS: PCF
Std Cnts: D 3445 M 26
Dens Cnt. 3568 Moist Cnt. 32
WD = - DD = -
PR = 145.0%PR = -
M = + %M = +++++
Optional Data:
1234567890.1
```

```
-----
STA # 2 2:30 PM 3/16/2000
DEPTH: 6 inches
TIME: 15 seconds UNITS: PCF
Std Cnts: D 3445 M 26
Dens Cnt. 3559 Moist Cnt. 27
WD = - DD = -
PR = 145.0%PR = -
M = + %M = +++++
```

Asphalt Mode

```
*****
PROJECT NUMBER: 2
SN: 59441 DATE: 3/16/2000
*****
STA # 1 2:34 PM 3/16/2000
DEPTH: Backscatter
2 ft left of centerline
TIME: 15 seconds UNITS: PCF
Std Cnts: D 3445 M 26
Dens Cnt. 3564 Moist Cnt. 29
WD = - DD = -
MA = 145.0%MA = -
M = + %M = +++++
Optional Data:
020590.01234
```

```
-----
STA # 2 2:35 PM 9/16/2000
DEPTH: Backscatter
5 ft right of centerline
TIME: 15 seconds UNITS: PCF
Std Cnts: D 3445 M 21
Dens Cnt. 3531 Moist Cnt. 28
WD = - DD = -
MA = 145.0 % VOIDS = +
Voidless Density = 145.0
%voidless = -
M = + %M = +++++
```

Figure 5–3. Sample Project Printouts

ERASE FUNCTION

The *Erase* function allows the operator to remove all project data stored in memory.

To select the *Erase* Function, press **<SHIFT>** and **<ERASE>** for the display

Press SHIFT/YES
to ERASE ALL
STORED DATA!
(CE to abort)

NOTE

The following step will erase all project data stored in the gauge's memory!

Press **<SHIFT>** and **<YES>** to erase all stored data. After erasing all project data from memory, the display will return to **READY**.

Note that “erased” data actually remains in memory until it is overwritten by new data. If project data is erased accidentally, it may be recovered using the *Recover Erase* function described on page 6–9.

NOTE

The *Recover Erase* function may not be able to recover erased project data if new data has been stored since the erasure took place.

COUNTS FUNCTION

The *Counts* function allows the operator to review the density and moisture counts from the last measurement taken with the gauge.

To execute the Counts function, press **<SHIFT>** and **<COUNTS>** for the display:

Dens ct. = xxxx
Moist ct. = xxxx
SHIFT/RECALL to
see Readings.

The moisture and density counts from the last reading will be displayed.

Press **<SHIFT>** and **<RECALL>** to view the individual readings. (Refer to the following pages for a more detailed description.)

RECALL FUNCTION

The *Recall* function allows the operator to review the last density and moisture readings.

To execute the *Recall* function, press **<SHIFT>** and **<RECALL>**. If the gauge is in *Soil* mode, the display will be:

```
%PR=xxxxx %  
DD=xxxxx PCF  
WD=xxxxx PCF  
M=xxxxx %M=xxxxx
```

If the gauge is in *Asphalt* mode, the display will be:

```
%MA=xxxxx %  
WD=xxxxx PCF  
M=xxxxx %M=xxxxx  
%VOIDS=xxxxx%
```

DEPTH FUNCTION

The *Depth* function allows the operator to select one of two depth modes: manual or automatic. In the *Manual* mode, the gauge prompts the operator to manually input the source rod depth using the keypad. In the *Automatic* mode, the gauge automatically reads the depth strip on the index rod, and then determines the source depth. To set the *Depth* mode, press **<SHIFT>** and **<DEPTH>**.

MANUAL MODE

If the *Depth* mode is set to *Automatic*, the gauge display is:

```
Depth Ind: Auto  
1- Select MANUAL  
Depth Indicator:  
MANUAL
```

To set the *Depth* mode to *Manual*, press **<1>** for:

AUTOMATIC MODE

If the *Depth* mode is set to *Manual*, the gauge allows the operator to change the mode. After changing the mode to *Automatic*, the gauge permits the operator to calibrate the depth strip.

NOTE

In the *Automatic* depth mode, the operator should calibrate the depth strip after extreme changes in temperature. The gauge automatically calibrates the depth strip when the operator takes a standard count. The gauge also allows the operator to calibrate the depth strip as follows.

To calibrate the depth strip, press **<SHIFT>** and **<DEPTH>**.



**Depth Ind: Auto
1- Select MANUAL
2- Calibrate
(CE to exit)**

Press **<2>**. The screen displays:



**-DEPTH Calib -
Set rod at:
SAFE POSITION
and press ENTER**

Position the source rod in the **SAFE** position and press **<START/ENTER>**. The gauge calibrates the depth strip. It then indicates that the depth indicator is in the automatic mode as shown below, and returns to the **READY** display.



**Depth Indicator:
AUTOMATIC**

CALCULATOR FUNCTION

The 3440 gauge can also be used as a four-function calculator. The calculator function keys are shown circled on the keypad in Figure 5-4.

To execute the *Calculator* function, press **<SHIFT>** and **<CALC.>** for the display:

**- CALCULATOR -
Use calculator
keys**

Pressing any numbered key will clear the display (with the exception of the top line).

ADDITION

To add 65 and 78: press **<6>**, **<5>**. Press **<+>**, **<7>**, **<8>**. Press **<=>**. The display will give an answer of **143**. Once a function has been completed and the answer is displayed (with the equal sign to the left), pressing any numbered key causes the display to clear (with the exception of the top line).

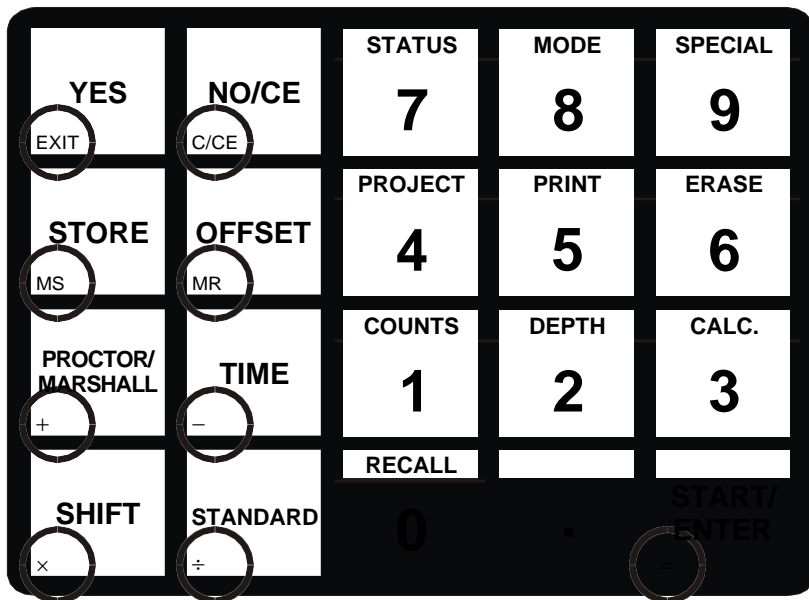

Figure 5-4. Calculator Function Keys

SUBTRACTION

To subtract 65 from 78: press $\langle 7 \rangle$, $\langle 8 \rangle$, $\langle - \rangle$, $\langle 6 \rangle$, $\langle 5 \rangle$, then $\langle = \rangle$. The displayed answer will be **13**.

DIVISION

To divide 39 by 3: press $\langle 3 \rangle$, $\langle 9 \rangle$, $\langle \div \rangle$, $\langle 3 \rangle$. Press $\langle = \rangle$ for the displayed answer of **13**.

MULTIPLICATION

To multiply 33 by 3: press $\langle 3 \rangle$, $\langle 3 \rangle$, $\langle \times \rangle$, $\langle 3 \rangle$. Press $\langle = \rangle$ for the displayed answer of **99**.

CHAIN CALCULATIONS

To perform a simple chain calculation, press $\langle = \rangle$ after each operation to get an intermediate result. For example, to perform the calculation $2 + 5 \times 9 - 3$ and divide the result by 5: press $\langle 2 \rangle \langle + \rangle \langle 5 \rangle$. Then press $\langle = \rangle$ to get the intermediate result of **7**. on the last line of the display. Press $\langle \times \rangle \langle 9 \rangle \langle = \rangle$. The figure following the equal sign will be **63**. Next, press $\langle - \rangle \langle 3 \rangle \langle = \rangle$ for a result of **60**. To divide this result by 5: press $\langle \div \rangle \langle 5 \rangle \langle = \rangle$ for the final answer of **12**.

A chain calculation such as $3+4(6+9)/2-8$ must be performed using algebraic notation: Parenthetical equations must be performed first, followed by multiplication and division operations; then by addition and subtraction. Therefore, the correct way to begin this calculation is: $\langle 6 \rangle \langle + \rangle \langle 9 \rangle \langle = \rangle$ to get the intermediate result of **15**.

Next, do the multiplication $\langle \times \rangle \langle 4 \rangle \langle = \rangle$ to get the next result of **60**.

The next step is division: entering $\langle \div \rangle \langle 2 \rangle \langle = \rangle$ brings the next result of **30**. Finally, addition and subtraction: press $\langle + \rangle \langle 3 \rangle \langle = \rangle$ and $\langle - \rangle \langle 8 \rangle \langle = \rangle$ for the final answer of **25**.

MEMORY STORAGE ARITHMETIC

Calculator mode also includes the *MS* (memory storage) and *MR* (memory recall) functions.

The *MS* function allows data to be stored in general memory for use with other calculations or data may be stored under a specific project and station number.

To use a numerical value as a constant (for instance, $\pi = 3.14159$) press the number keys and decimal in the proper order. When the displayed figure is **3.14159**, press **(MS)**.

The display will be:

Select Storage:
1- Calculator
2- Project

Press **(1)** to store the data. An **S** will appear on the display to the right of the figure, indicating the decimal number sequence of **3.14159** was stored.

If data is to be stored under a station number, press **(2)**. The display will be:

Station Number?
Press ENTER
when completed.

Input the station number and press **(START/ENTER)**. The value will be stored.

To Recall stored values for use in calculations, press **(MR)** and the stored figures will appear on the display. An **R** will appear to the right of the figure to indicate that the value is recalled from memory and not a keyboard entry.

This figure can now be used as a constant. To change the constant or put a different figure in memory, enter the new figure and press **(MS)**, or press **(MS)** after a final result on the last line of the display. Figures in the calculator memory can be used in calculations in the same manner as figures entered separately. The figures in calculator memory may also be recalled as long as:

- ◆ The gauge batteries do not become completely discharged or removed.
- ◆ The calculator memory is not cleared.
- ◆ The values are not changed or replaced with another set of figures.

To clear the calculator memory, press **(0)** and **(MS)**.

Press **(EXIT)** to leave the calculator mode. The display will return to **READY**.

CHAPTER 6

SPECIAL FUNCTIONS

This chapter contains descriptions and operation instructions for the *Special Functions* of the Series 3440 Surface Moisture-Density Gauge. These functions are typically not used on a day-to-day basis. In many cases, these functions are used only one time for gauge configuration and remain unchanged. The functions are arranged in order of use by a typical gauge operator with the *Stat Test* and *Drift Test* listed first and continuing through the *Source Decay* and *Special Rdwy* functions.

CONTENTS

Stat Test.....	6-3
Viewing Stat Test Data	6-5
Printing Stat Test Data	6-6
Drift Test.....	6-7
Execute Drift Test	6-7
Viewing Drift Test Data.....	6-8
Recover Erase.....	6-9
Keypad Data.....	6-10
Auto-Station	6-11
Special Calibration	6-12
Enable Special Calibration	6-12
Disable a Special Calibration	6-13
Perform a Special Calibration (Recalibration)	6-13
Nomograph.....	6-15
Enable Nomograph	6-16
Disable Nomograph	6-16
Change/View Nomograph Data	6-16
Precision.....	6-22

CONTENTS (Continued)

Set Units 6-24

Baud Rate 6-25

Communication Protocol 6-26

Battery Monitor 6-27

 Battery Monitor 6-27

 Battery Status 6-29

Source Decay 6-30

Special Roadway 6-31

STAT TEST

The *Stat Test*, or statistical stability test, may be performed to validate the normal operation of the gauge. Erratic readings or readings that seem to fluctuate may indicate a problem with the gauge. If the readings are suspect, the stat test may be executed.

A stat test should result in a ratio of actual-to-predicted standard deviation. Ideally, the ratio should be 0.25, but acceptable limits are between 0.17 and 0.33. A definite instability exists if the ratio is outside these limits. Contact the nearest Troxler Service Center for additional instructions.

To execute the stat test, press **<SHIFT>** and **<SPECIAL>** for the display:

```
SPECIAL FUNCTION
YES- Next menu
1- STAT TEST
2- DRIFT TEST
```

Press **<1>** for the display:

```
- STAT TEST -
Want to view
last Stat data?
```

If **<YES>** is pressed to view the last stat test data, the display is:

```
DENS STAT TEST
Avg cnts: xx
R: x.xxx
-ENTER for Moist
```

To view the moisture data from the last stat test, press **<START/ENTER>**. The display is:

```
MOIST STAT TEST
Avg cnts: xx
R: x.xxx
View Stat. data?
```

The data for each of the readings may be viewed on the screen as described on page 6-5.

If **<NO/CE>** is pressed from the **Want to view...?** screen on the previous page, the display is:

**Put gauge on Std
Block, rod in
SAFE position &
press START**

For a stat test, place the reference standard block on a high-density surface (at least 100 pcf (1602 kg/m³)) that is 5 ft (1.5 m) from a vertical surface. Following the instructions given on the display, place the gauge on the reference standard block with the source rod in the **SAFE** position.

Press **<START/ENTER>** for the display:

**- STAT TEST -
Reading #1
Time= 60 secs**

The gauge will take twenty 60-second counts. When all counts are complete, the screen will display the average counts and ratio.

**DENS STAT TEST
Avg cnts: xx
R: x.xxx
-ENTER for Moist**

To view the moisture data, press **<START/ENTER>**. The display is:

**MOIST STAT TEST
Avg cnts: xx
R: xxxx
View Stat. data?**

Press **<YES>** for the display:

**Select method of
viewing data:
1- Screen
2- Printout**

VIEWING STAT TEST DATA

From the **Select method of viewing...** screen on page 6-4, press **<1>** for the display:

**- STAT TEST -
Press SHIFT to
roll thru data**

Press **<SHIFT>** for the display:

**Stat. Counts #1
Density: x
Moisture: x
(Press SHIFT)**

Press **<SHIFT>** and the gauge will display all twenty counts on the screen.

After the last count, the display will be:

**DENS STAT TEST
AVG cnts: xx
R: x.xxx
-ENTER for Moist**

To view the moisture data, press **<START/ENTER>**. The display is:

**MOIST STAT TEST
Avg cnts: xx
R: x.xxx
View Stat. data?**

Press **<NO/CE>** and the gauge will return to the **READY** display.

PRINTING STAT TEST DATA

From the **Select method of viewing...** screen on page 6-4, press **(2)** for the display:



After connecting the printer to the serial connector on the gauge, press **(START/ENTER)** for the following display. Figure 6-1 shows a sample stat test printout.



If the printer is not connected properly, an error message will be displayed.

```
*****
Statistical Stability Test
*****
Gauge Serial #: 18326
5/04/2000 7:21 AM

READING | COUNTS
# | DENSITY MOISTURE
1 3721 617
2 3725 639
3 3746 624
4 3740 617
5 3737 616
6 3744 628
7 3687 621
8 3748 628
9 3735 627
10 3737 623
11 3711 621
12 3729 622
13 3757 619
14 3732 602
15 3734 630
16 3749 623
17 3729 618
18 3726 619
19 3742 618
20 3743 618
Average: 3734 622
Ratio: 0.252 0.292
(PASS) (PASS)
*****
```

Figure 6-1. Stat Test Printout Sample

DRIFT TEST

If the stat test has already been performed (and has passed), but gauge readings seem to be fluctuating from test to test, the *Drift Test* can be performed to check the long-term drift of the 3440.

Pass and Fail limits are averages from the stat test and the difference in the drift test average. If the average differences exceed 0.5% for density or 1% for moisture, contact your Troxler service department.

Without turning off or moving the gauge from the time the stat test was taken, wait 3 to 8 hours and implement the drift test.

NOTE

The gauge should not be turned off between the stat and drift tests. The stat test must be current. The gauge must not be moved between the stat and drift tests to eliminate possible failure due to positioning changes.

To execute the drift test, press **<SHIFT>** and **<SPECIAL>** for the display:

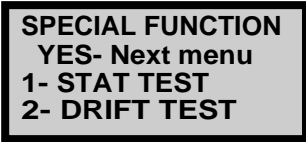

**SPECIAL FUNCTION
YES- Next menu
1- STAT TEST
2- DRIFT TEST**

Press **<2>** for the display:



**- DRIFT TEST -
Want to view
last Drift data?**

EXECUTE DRIFT TEST

To execute the drift test, press **<NO/CE>** at the above display:

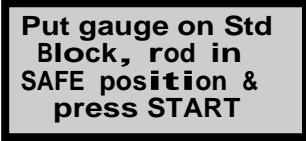

**Put gauge on Std
Block, rod in
SAFE position &
press START**

Place the gauge on the reference standard block. Make sure the source rod is in the **SAFE** position and press **<START/ENTER>**. The display will be:

```

- DRIFT TEST -
Read #x Time:xxx
    
```

After the gauge completes five 4-minute counts, the display will be:

```

DENS DRIFT TEST
Avg cnts:  xx
Drift:  x.x  % P
-ENTER for Moist
    
```

To view the moisture data from the last drift test, press **<START/ENTER>**. The display is:

```

MOIST DRIFT TEST
Avg cnts:  xx
Drift:  x.x  % P
View Drift data?
    
```

VIEWING DRIFT TEST DATA

The data for each of the readings may be viewed on the screen or may be printed. This function is the same as viewing the stat test data.

Refer to page 6-5 for instructions on viewing or printing drift test data. Figure 6-2 shows a sample drift test printout.

```

*****
DRIFT TEST
*****
Gauge Serial #: 123456
05/09/2000    3:01 PM

READING |          COUNTS
#       |  DENSITY  MOISTURE
-----|-----
 1      |  3769     672
 2      |  3801     661
 3      |  3777     670
 4      |  3740     694
 5      |  3669     660
Average: | 3751     671
Drift:   | 0.3 %    0.2 %
          | (PASS)   (PASS)
*****
    
```

Figure 6-2. Drift Test Printout Sample

RECOVER ERASE

The *Recover Erasure* function may be used if project data is erased accidentally.

NOTE

The *Recover Erasure* function may not be able to recover erased data if other data has been stored since the erasure took place.

To execute the *Recover Erasure* function, press **<SHIFT>** and **<SPECIAL>** for:

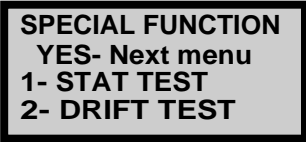

SPECIAL FUNCTION
YES- Next menu
1- STAT TEST
2- DRIFT TEST

Press **<YES>** one time for the display:



YES- Next menu
3- RECOVER ERASE
4- KEYPAD DATA
5- AUTO STATION

Press **<3>** for the display:



All data is
RECOVERED!

KEYPAD DATA

The *Keypad Data* function allows the operator to store numeric information under a particular station number. This numeric information may only be stored under the current project number and may be viewed or printed using the *Project* function.

To execute the *Keypad Data* function, press **⟨SHIFT⟩** and **⟨SPECIAL⟩** for:

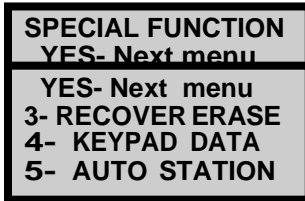

Press **⟨YES⟩** one time for the display:

Press **⟨4⟩** for the display:

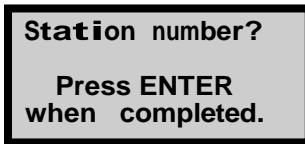

Input a previously stored Station Number. Press **⟨START/ENTER⟩** for:



Input any sequence of numeric digits (up to 12) and press **⟨START/ENTER⟩**.

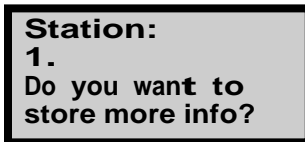

Press **⟨YES⟩** or **⟨NO/CE⟩**.

AUTO-STATION

The *Auto-Station* function allows the operator to initialize a station number. When this function is enabled, the gauge will automatically increment the station number by one after each reading is stored.

To enable the *Auto-Station* function, press **<SHIFT>** and **<SPECIAL>** for:



SPECIAL FUNCTION
YES- Next menu
1- STAT TEST
2- DRIFT TEST

Press **<YES>** one time for the display:



YES- Next menu
3- RECOVER ERASE
4- KEYPAD DATA
5- AUTO STATION

Press **<5>** for the display:



Auto-Station
DISABLED
Do you want to
ENABLE?

Press **<YES>** to enable this function. The display will request the first station number.

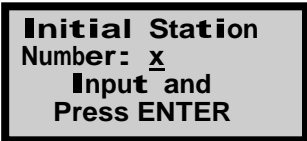

Initial Station
Number: x
Input and
Press ENTER

Input any sequence of numeric digits and press **<START/ENTER>**.

The gauge will return to the **READY** display.

NOTE

Whenever a new project number is entered into the gauge, the *Auto-Station* function is automatically disabled.

SPECIAL CALIBRATION

The *Special Calibration* function allows the operator to re-calibrate the gauge constants temporarily for use in measuring particular materials. These materials may be limestone or other materials that do not fall within the range of a normal calibration. Once enabled, the *Special Calibration* will remain in effect until the gauge is turned off or *Normal* calibration is re-enabled.

To execute *Special Calibration*, press **<SHIFT>** and **<SPECIAL>** for:

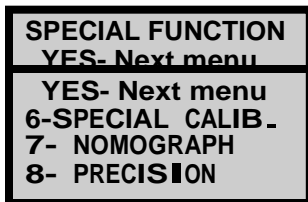

A rectangular display box with a black border containing the following text:
SPECIAL FUNCTION
YES- Next menu
YES- Next menu
6-SPECIAL CALIB-
7- NOMOGRAPH
8- PRECISION

Press **<YES>** two times for the display:

Press **<6>** for the display:

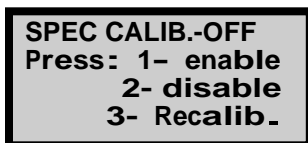

A rectangular display box with a black border containing the following text:
SPEC CALIB.-OFF
Press: 1- enable
2- disable
3- Recalib-

At this time, the operator may either enable an existing special calibration or disable an existing calibration that has been in use. The operator may also re-calibrate the gauge for use in a different material.

ENABLE SPECIAL CALIBRATION

Press **<1>** to enable the calibration. The display will be:

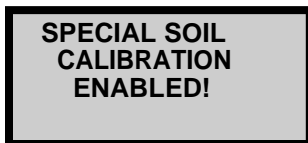

A rectangular display box with a black border containing the following text:
SPECIAL SOIL
CALIBRATION
ENABLED!

The gauge will return to the **READY** display.

DISABLE A SPECIAL CALIBRATION

To disable a previously enabled special calibration, press **(2)** from the **SPEC CALIB.** menu. The display will be:

A rectangular display box with a black border containing the text: **NORMAL
CALIBRATION
ENABLED!**

The gauge will return to the **READY** display.

PERFORM A SPECIAL CALIBRATION (RECALIBRATION)

Before performing a special calibration, the following steps must be taken:

1. The sample area must be prepared for testing.
2. Gauge readings must be taken on each area.
3. A *wet density* measurement using an alternative method must be performed.

To perform a new special calibration, prepare a test site and position the gauge. Position the rod at the correct depth and press **(3)** from the **SPEC CALIB.** menu. The display will be:

A rectangular display box with a black border containing the text: **Input rod depth:
(Enter 0 for BS)
x inches
(Press ENTER)**

Press **(START/ENTER)** after input of the rod depth. The display is:

A rectangular display box with a black border containing the text: **SPECIAL CALIB.
Depth: x inches
Time: x min.
Press START**

Press **<START/ENTER>** to begin taking the measurement. The display will be:

**SPECIAL CALIB.
Depth: x inches
Time:xxx secs.**

After counting down to zero, the display will be:

**Dens ct.=xxxx
Moist ct.=xxxx
To input sample
dens Press ENTER**

Press **<START/ENTER>** to input the sample area *wet density* obtained from the alternative test method. The display will be:

**Input material
density -
x-x PCF
ENTER to ENABLE**

Input the material density and press **<START/ENTER>**. The display will return to **READY**.

NOMOGRAPH

In some cases, the 3440 may be used to determine the density of thin asphalt overlays. This measurement may be performed with the gauge in backscatter mode and using the “Nomograph” method of density measurement. It should be noted that this method is not as accurate as a true thin-layer gauge. However, this method may produce satisfactory results under many conditions.

When a nuclear gauge is used in backscatter mode on overlays under 3 in. (7.5 cm), several effects must be overcome to produce an accurate reading. With most gauges, the primary problem is the result of photons from the source penetrating deeper than 3 in. (7.5 cm) and scattering back to the gauge. These backscattered photons from the underlying material will adversely influence the reading.

Obtaining an accurate overlay density with the Nomograph method requires that the density of the bottom layer and the thickness of the top layer be determined. The simplest method of determining the density of the bottom layer is to take a nuclear gauge measurement prior to applying the top layer or overlay. With the overlay applied and compacted, the depth of the layer should be determined. At this time, the gauge may be used to calculate the overlay layer density.

To access the *Nomograph* function, press <SHIFT> and <SPECIAL> for:

SPECIAL FUNCTION
YES- Next menu
1- STAT TEST
2- DRIFT TEST

Press <YES> two times for the display:

YES- Next menu
6-SPECIAL CALIB.
7- NOMOGRAPH
8- PRECISION

Press <7> for the display:

NOMOGRAPH - OFF
Press: 1- enable
2- disable
3- chg/view data

At this time, the operator may enable, disable, or change the *Nomograph* function.

ENABLE NOMOGRAPH

Press **<1>** from the display at the bottom of page 6–15 to enable the *Nomograph* function. The display will be:

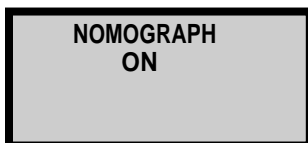

The gauge will return to the **READY** display.

DISABLE NOMOGRAPH

To disable the *Nomograph* function, press **<2>** from the display at the bottom of page 6–15. The display will be:

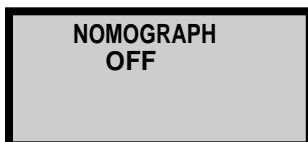

The gauge will return to the **READY** display.

CHANGE/VIEW NOMOGRAPH DATA

To change or view the function data, press **<3>** from the display at the bottom of page 6–15. The display will be:

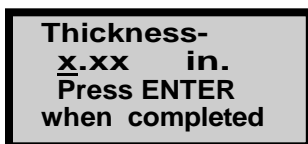

Input the desired overlay thickness. Press **<START/ENTER>**. The display is:

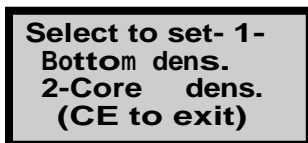

The wet density of the underlying or base material may be input using one of two methods: keypad entry or by using the gauge to record actual measurements.

Bottom Density – Keypad Entry

From the **Select to set-** display, press **<1>** for:

**Average bottom
density:
x.x PCF
Want to change?**

If the display value is correct, press **<NO/CE>**.

Press **<YES>** if the value is to be changed. The display will be:

**Select method of
Entering density
1 - Keypad
2 - Measure**

Press **<1>** to enter data with the keypad. The display will be:

**Bottom density-
x-x PCF
Press ENTER
when completed**

Enter the density of the bottom layer. The next display will be:

**NOMOGRAPH
ON**

Bottom Density – Measurement Entry

Bottom density values may be obtained by using the gauge to record an actual measurement. Follow the instructions from the *Bottom Density – Keypad Entry* description on the previous page until reaching the **Select method of...** display.

Press **(2)** for measurement entry. The display will be:

**# of Readings to
average (1-20)?
x
Press ENTER**

Input the number of readings to be taken and averaged. Press **(START/ENTER)** for the display:

**- Reading # 1 -
Time: x min.
Set rod to BS &
Press START**

Prepare the site for measurement. Position the gauge and press **(START/ENTER)**. The display will be:

**- NOMOGRAPH -
Reading # 1
Reading # 1
WD:xxxxx PCF
Move gauge and
press START**

After counting down to zero, the display will be:

If more than one reading is to be taken, move the gauge to the next location and press **(START/ENTER)**. The gauge will repeat the above sequence for each reading. When all the readings are completed, the display will be:

**Average of x
Reading(s)-
xxxxx PCF
Press ENTER**



From the previous display, press **<START/ENTER>**. The display will be:

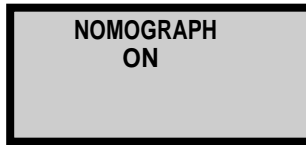

NOMOGRAPH
ON

Thin-layer overlay measurements may now be taken. Press **<START/ENTER>** to begin the test. The display is:

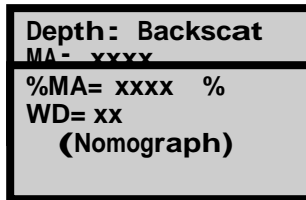

Depth: Backscat
MA- xxxx
%MA= xxxx %
WD= xx
(Nomograph)

After counting down to zero, the display is:

This test may be stored as any other test measurement. The recall function and/or printout will show that the *Nomograph* function was used.

NOTE

Nomograph mode should be disabled before taking any measurements not requiring the *Nomograph* function.

Core Density – Keypad Entry

The *Core Density* method allows the operator to input the density value of a core sample for determining the overlay density.

From the **Select to set-** display at the bottom of page 6-16, press **(2)**. The display is:

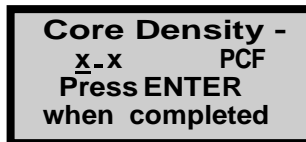

Core Density -
x.x PCF
Press ENTER
when completed

If the displayed density is correct, press **<START/ENTER>**. If a change is required, input the new value and press **<START/ENTER>**.

The display will be:

Average measured
density-
x.x PCF
Want to change?

If the displayed value is correct, press **(NO/CE)**.

Press **(YES)** if the value is to be changed. The display will be:

Select method of
Entering density
Measured dens.-
x-x PCF
Press ENTER
when completed

Press **(1)** to enter data with the keypad. The display will be:

Input the average measured density and press **(START/ENTER)**. The gauge will return to the **READY** display. Measurements may now be taken and stored. These measurements should represent the density at or near the core locations.

Core Density – Measurement Entry

From the **Select method of...** display above, press **(2)**. The display is:

of Readings to
average (1-20)?
x
Press ENTER

Input the number of readings to be taken and averaged. Press **(START/ENTER)** for the display:

- Reading # 1 -
Time: x min.
Set rod to BS &
Press START



Prepare the site for measurement. Place the gauge near the core location and press **<START/ENTER>**. The display will be:

**- NOMOGRAPH -
Reading # 1
Depth: BS
Time:xx sec.**

After counting down to zero, the display will be:

**Reading # 1
WD:xxxxx PCF
Move gauge and
press START**

If more than one reading is to be taken, move the gauge to the next location and press **<START/ENTER>**. The gauge will repeat the above sequence for each reading. When all the readings are completed, the display will be:

**Average of x
Reading(s)-
xxxxx PCF
Press ENTER**

Press **<START/ENTER>** to return to the **READY** display. Thin layer overlay measurements may be taken and stored at this time.

PRECISION

Test results with precision limits as low as 0.5 pcf (8 kg/m³) are possible under certain conditions. When given the desired degree of precision and a test measurement, the 3440 automatically supplies this precision data to the operator. Assuming the precision requested is within range and the time required to calculate the required result does not exceed 60 minutes, the following procedure can usually produce the required results.

The operator should be certain that the gauge is in the correct mode: *Soil* or *Asphalt*. To execute the *Precision* function, press **<SHIFT>** and **<SPECIAL>** for:

SPECIAL FUNCTION
YES- Next menu
1- STAT TEST
2- DRIFT TEST

Press **<YES>** two times for the display:

YES- Next menu
6-SPECIAL CALIB.
7- NOMOGRAPH
8- PRECISION

Press **<8>** for the display:

Precision:
x.xx PCF
Press ENTER
when completed

If the gauge is in *Soil* mode, the display will request that the gauge be set for the correct depth and will instruct you to press **<START/ENTER>**.

Set depth for
1-min. count.
Press START
when ready.

If the gauge is in *Asphalt* mode, the display will reflect that the gauge should be in the backscatter position.

Depth: xx
1 min. count.
Press START
when ready.

If the gauge is in the correct position, press **<START/ENTER>**. The display will be:

```
Precision Mode
Depth: xx
Time: xx sec
1-min. count
```

After counting down to zero, the display will be:

```
xx min. to
reach precision.
Want to begin?
Press CE to exit
```

Press **<YES>**. After counting down, the display will be:

(For *Soil* mode)

```
%PR= xxx %
DD= xxx
WD= xxx
M= xx %M= xx
```

(For *Asphalt* mode)

```
%MA= xxxx %
WD= xx
```

NOTE

If the required precision cannot be reached in 60 minutes, the following screen will be shown displayed.

```
-WARNING-Time to
reach precision
too high!
Press CE to exit
```

The precision mode will remain enabled until the gauge is turned off for more than ten seconds.

SET UNITS

The 3440 gauge allows the operator to select whether screen displays and printouts use measurement units of *Metric* or *PCF*. The *Set Units* function is described on page 2–4.

BAUD RATE

The speed at which characters are transmitted to a printer or computer is determined by the setting of this special function. The baud rate is normally configured at bps or *bits per second*. A speed of 300 baud would then be approximately 300 bps.

Valid baud rates for the 3440 gauge are 300, 600, 1200, 2400, and 4800.

To execute the *Baud Rate* function, press **<SHIFT>** and **<SPECIAL>** for:

SPECIAL FUNCTION
YES- Next menu
1- STAT TEST
2- DRIFT TEST

Press **<YES>** three times for the display:

YES- Next menu
9- SET UNITS
Baud Rate = 600
Do you want to
make a change?

Press **<1>** **<0>** for the display:

Press **<YES>** to change the baud rate. The display will be:

Baud rate = 600
Input new rate.
Press ENTER
when finished.

Input the new baud rate and press **<START/ENTER>**. After a few seconds, the display will return to **READY**.

NOTE

If the wrong baud rate is entered, the error message – ERROR– Illegal baud rate is briefly displayed. The gauge then returns to the Do you want to make a change? display shown above.

COMMUNICATION PROTOCOL

The *Communication Protocol* function allows the operator to select whether a *Line Feed* is transmitted with a *Carriage Return* when the gauge is communicating with a printer or other external device.

Consult the owners manual of your particular device to determine if you need to send a line feed. To execute the *Communication Protocol* function, press **<SHIFT>** and **<SPECIAL>** for:

SPECIAL FUNCTION YES- Next menu
YES- Next menu 9- SET UNITS 10- BAUD RATE 11- COMM PROTOCOL

Press **<YES>** three times for the display:

Press **<1>** **<1>** for the display:

Comm. Protocol: Send LF w/ CR
Comm. Protocol Select: 1- Send LF w/CR 2- No LF w/CR

Press **<YES>** for the display:

Select the appropriate protocol by pressing **<1>** or **<2>**. After entering a selection, the display will reflect the new protocol.

Comm. Protocol: No LF w/CR.
--

BATTERY MONITOR

The *Battery Monitor* function provides the operator with multiple methods for displaying the battery status. The recommended display method is actual battery voltage. However, the other choices may be useful. The following choices are available:

- ◆ Display the actual battery voltage
- ◆ Display the estimated battery life
- ◆ Display the elapsed time from the last charge

To execute the *Battery Monitor* function, press **<SHIFT>** and **<SPECIAL>** for:



SPECIAL FUNCTION
YES- Next menu
1- STAT TEST
2- DRIFT TEST

Press **<YES>** four times for the display:

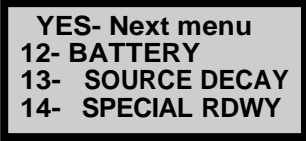

YES- Next menu
12- BATTERY
13- SOURCE DECAY
14- SPECIAL RDWY

Press **<1>** **<2>** for the display:

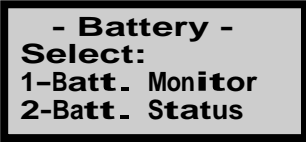

- Battery -
Select:
1-Batt. Monitor
2-Batt. Status

BATTERY MONITOR

To change the way the battery is monitored and displayed, press **<1>** for:



Battery Monitor-
1-Batt. Life
2-Batt. Voltage
3-Elapsed Time

Battery Monitor – Battery Life

Press **<1>** to display battery life. The display will be:

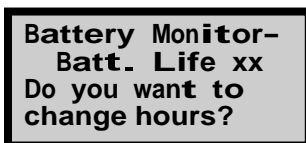

**Battery Monitor-
Batt. Life xx
Do you want to
change hours?**

If the battery hours remaining are correct, press **<NO/CE>**. The gauge will return to the **READY** display. The remaining hours will be displayed.

Press **<YES>** if the hours are to be changed. The display is:

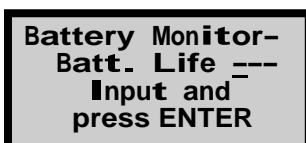

**Battery Monitor-
Batt. Life ---
Input and
press ENTER**

After inputting the new hours, the gauge will return to **READY**.

Battery Monitor – Battery Voltage

If the battery voltage is to be displayed on the **READY** screen, press **<2>** from the first **Battery Monitor-** display. The gauge will return to the **READY** display. The battery voltage will be shown on the third line of the display.

Battery Monitor – Elapsed Time

If the elapsed time is to be displayed on the **READY** screen, press **<3>** from the **Battery Monitor-** display. The display will be:



**Battery Monitor-
Elapsed Time xxx
Want to reset
Elapsed Time?**

If the elapsed time shown is to be reset to zero, press **<YES>**. The gauge will return to the **READY** display.

BATTERY STATUS

The battery status may be checked at any time. From the – **Battery** – menu on page 6–27, press **<2>**. The display will be:

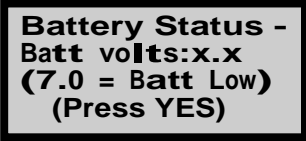

Battery Status -
Batt volts:x.x
(7.0 = Batt Low)
(Press YES)

Press **<YES>** to view the date when the gauge was last charged, how long the charge was and how many hours have elapsed since that charge. The display will be:

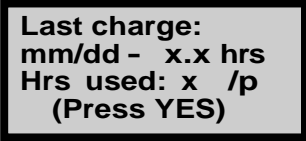

Last charge:
mm/dd - x.x hrs
Hrs used: x /p
(Press YES)

Press **<YES>** and the gauge will return to **READY**.

SOURCE DECAY

The *Source Decay* function calculates a theoretical set of standard counts. The radiation intensity of the source decreases by 2.3% per year. To compensate, the last calibration standard counts are “corrected” mathematically. The correction formula uses daily increments to compensate the calibration standard count. The “corrected” counts may be compared to the existing daily standard counts to determine if the gauge is operating properly.

To execute the *Source Decay* function, press **<SHIFT>** and **<SPECIAL>** for:

```
SPECIAL FUNCTION
YES- Next menu
1- STAT TEST
2- DRIFT TEST
```

Press **<YES>** four times for the display:

```
YES- Next menu
12- BATTERY
13- SOURCE DECAY
14- SPECIAL RDWY
```

Press **<1> <3>** for the display:

```
Std after Decay:
Current: xx
Predicted: xx
%Diff: xx
```

After a brief delay, the gauge will return to the *Ready* mode.

SPECIAL ROADWAY

After taking readings and pressing **(STORE)**, operators can let the gauge prompt them for the information required on U.S. FHWA projects. The gauge can then *download* the readings and other information to a computer or serial printer.

When shipped from the factory, the default storage mode is the standard storage mode. To change the storage mode, select the *Special Rdwy* option on the *Special* function menu. The gauge will display the current status.

Press **(SHIFT)** and **(SPECIAL)**, then **(1)****(4)** for:

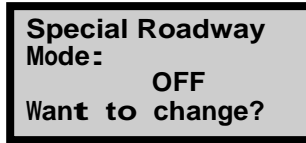

The **(YES)** key toggles the function on and off. To accept the displayed status, press **(NO/CE)**. Once the storage mode is changed, the gauge will remain in this mode until it is changed again.

In both the *Asphalt* and *Soil* mode, the gauge can prompt the operator for:

- ◆ FHWA number
- ◆ Station number
- ◆ Distance from centerline
- ◆ Lane direction
- ◆ Elevation above original ground
- ◆ Elevation below finished grade
- ◆ Compaction method

In the *Asphalt* mode, the gauge can prompt the operator for:

- ◆ Lift number
- ◆ Lift thickness
- ◆ Test type (surface mix, intermediate mix, or base mix)

In the *Soil* mode, the gauge can prompt the operator for:

- ◆ Test type (soils or stone)
- ◆ Further test type (embankments, pipe backfill, subgrade, abutment backfill, retaining wall, or rockfill)
- ◆ If backfill, then pipe size
- ◆ If soil, then density required

NOTES

CHAPTER 7

EXTENDED FUNCTIONS

This chapter contains descriptions and operational instructions for the *Extended Functions* of the Series 3440 Surface Moisture-Density Gauge. These functions require the use of an *Access Code* and are to be executed by authorized personnel only.

CONTENTS

Time/Date.....	7-2
Customer Name.....	7-3
Serial Number	7-4
Calibration Date	7-5
Calibration Constants	7-6
Rod Length.....	7-8
Erase Standard Counts	7-9
Memory Clear	7-10
Burn-In.....	7-10
Calibration Standard.....	7-11
Remote Control	7-12

TIME/DATE

The *Time/Date* function allows the operator to change the current time-of-day or date that is displayed on the screen and used for measurement reports. This function is described on page 2–11.

CUSTOMER NAME

The *Customer Name* function allows the operator to enter or change the name of the gauge owner for printouts and reports. To execute the *Customer Name* function, press **(SHIFT)** and **(SPECIAL)** for:

```
SPECIAL FUNCTION
YES- Next menu
1- STAT TEST
2- DRIFT TEST
```

Press **(19)** for the display:

```
EXTENDED
FUNCTIONS
Enter Code----
and Press ENTER
```

The *Access Code* must be entered. This code is for authorized personnel only. If you need assistance with the code, contact your nearest Troxler Representative.

Enter the code and press **(START/ENTER)**. The display will be:

```
YES- Next menu
1- Time/Date
2- Customer Name
3- Serial Number
```

Press **(2)** for the following display:

```
Customer name
-----
Do you want to
change name?
```

Press **(YES)** to change the name.

```
A-----
SHIFT- See chars
YES- Select
ENTER- Finished
```

Press **(SHIFT)** to view a character of the alphabet. Press **(YES)** to select the character and advance the cursor to the next space.

When the name entry is complete, press **(START/ENTER)**. The display will return to the *Extended Functions* menu.

SERIAL NUMBER

The *Serial Number* function allows the operator to change the serial number of the gauge if this value is lost in memory. To execute the *Serial Number* function, press **<SHIFT>** and **<SPECIAL>** for:

SPECIAL FUNCTION
YES- Next menu
1- STAT TEST
2- DRIFT TEST

Press **<19>** for the display:

EXTENDED
FUNCTIONS
Enter Code----
and Press ENTER

The *Access Code* must be entered. This code is for authorized personnel only. If you need assistance with the code, contact your nearest Troxler Representative.

Enter the code and press **<START/ENTER>**. The display will be:

YES- Next menu
1- Time/Date
2- Customer Name
3- Serial Number

Press **<3>** for the following display:

Serial Number-

Want to change
Serial Number?

Press **<YES>** to change the current number. The display is:

Serial Number-
=
Input new Number
and press ENTER

Using the numeric keys, input the new serial number.

When the input is complete, press **<START/ENTER>**. The display will return to the *Extended Functions* menu.

CALIBRATION DATE

The *Calibration Date* function allows the operator to change the date of the last gauge re-calibration. To execute the *Calibration Date* function, press **<SHIFT>** and **<SPECIAL>** for:

SPECIAL FUNCTION
YES- Next menu
1- STAT TEST
2- DRIFT TEST

Press **<19>** for the display:

EXTENDED
FUNCTIONS
Enter Code----
and Press ENTER

The *Access Code* must be entered. This code is for authorized personnel only. If you need assistance with the code, contact your nearest Troxler Representative.

Enter the code and press **<START/ENTER>**. The display will be:

YES- Next menu
1- Time/Date
2- Customer Name
3- Serial Number

Press **<YES>** for the following display:

YES- Next menu
4- Calib. Date
5- Calib. Const.
6- Rod Length

Press **<4>** for the display:

DATE OF Calib:

Press ENTER
when complete.

Using the numeric keys, input the new date. Press **<START/ENTER>** when completed. The display will return to the *Extended Functions* menu.

CALIBRATION CONSTANTS

The *Calibration Constants* function allows the operator to change the *constants* that the gauge uses to calculate a test result. If the gauge has been repaired, or the memory has been lost, the constants must be re-entered.

NOTE

Each gauge contains a unique set of constants. These constants are developed at the factory and are reflected on the factory calibration sheet, which is shipped with every gauge. If the constants are changed or are entered incorrectly, gauge measurements will be incorrect.

To execute the *Calibration Constants* function, press **<SHIFT>** and **<SPECIAL>** for:

SPECIAL FUNCTION
YES- Next menu
1- STAT TEST
2- DRIFT TEST

Press **<19>** for the display:

**EXTENDED
FUNCTIONS**
Enter Code----
and Press ENTER

The *Access Code* must be entered. This code is for authorized personnel only. If you need assistance with the code, contact your nearest Troxler Representative.

Enter the code and press **<START/ENTER>**. The display will be:

YES- Next menu
1- Time/Date
2- Customer Name
3- Serial Number

Press **<YES>** for the following display:

YES- Next menu
4- Calib. Date
5- Calib. Const.
6- Rod Length

Press <5> to select *Calibration Constants*. The display will be:

```
-CALIB. CONST.-  
Enter Code ----  
and Press ENTER
```

The *Secondary Access Code* must be entered. Enter the code and press <START/ENTER>. The display is:

```
-CALIB. CONST.-  
E=x  
Select:  1 = +  
         2 = -
```

If the value for the “E” constant on the screen equals that shown on the calibration sheet, press <START/ENTER> to select the next constant.

If the “E” value is not correct, press <1> for positive number or <2> for negative number and enter the value as reflected on the factory calibration sheet. Press <START/ENTER> when completed.

NOTE

If your calibration sheet lists B*1000 and F*1000 values, the calibration is in metric units. Therefore, the values on the calibration sheet can be entered into the gauge without conversion.

If your calibration sheet lists B and F values, then the calibration is in English units rather than metric. Because the gauge requires metric units, the B and F values must be converted to metric units and divided by 1000. The most direct conversion method is to multiply the B and F values by 62.4298, then enter the resulting product into the gauge.

The gauge will request a new value for the “F” constant. After accepting or entering a corrected value for the “F” constant, the gauge requests a depth value. The display is:

```
-CALIB. CONST.-  
Enter depth:  
= inches  
(Press ENTER)
```

After the depth entry (0 for *backscatter*, 2 for 2 inches, etc.), accept or enter the “A”, “B*1000” and “C” constants from the calibration sheet.

Repeat this procedure for every depth shown on the calibration sheet. When all constants have been entered, the display will return to the *Extended Functions* menu.

ROD LENGTH

If the gauge depth seems incorrect after calibrating the depth, the *Rod Length* function allows the operator to set the rod length manually. The operator should not need to set the rod length unless a new front panel assembly is installed or the RAM is corrupt. To set the rod length manually, press **<SHIFT>** and **<SPECIAL>** for:

SPECIAL FUNCTION
YES- Next menu
1- STAT TEST
2- DRIFT TEST

Press **<19>** to display:

**EXTENDED
FUNCTIONS**
Enter Code----
and Press ENTER

The *Access Code* must be entered. This code is for authorized personnel only. If you need assistance with the code, contact your nearest Troxler Representative.

Enter the code and press **<START/ENTER>**. The display will be:

YES- Next menu
1- Time/Date
2- Customer Name
3- Serial Number

Press **<YES>** for:

YES- Next menu
4- Calib. Date
5- Calib. Const.
6- Rod Length

To access the *Rod Length* function, press **<6>**. The gauge provides the operator with two rod-length options: 8 or 12 inches. The display is

Set Rod Length
Select:
1- 8 Inch
2- 12 Inch

Press **<1>** or **<2>** to select the correct rod length. The gauge returns to the *Extended Functions* menu. To return to the *Ready* mode, press **<NO/CE>**.

If taking measurements in the automatic indicator mode, the operator should calibrate the depth strip after manually entering the rod length.

ERASE STANDARD COUNTS

The *Erase Standard Counts* function allows the operator or service technician to remove all (four) standard counts from gauge memory.

To execute the *Erase Standard Counts* function, press **(SHIFT)** and **(SPECIAL)** for:

SPECIAL FUNCTION
YES- Next menu
1- STAT TEST
2- DRIFT TEST

Press **(19)** for the display:

EXTENDED
FUNCTIONS
Enter Code----
and Press ENTER

The *Access Code* must be entered. This code is for authorized personnel only. If you need assistance with the code, contact your nearest Troxler Representative.

Enter the code and press **(START/ENTER)**. The display will be:

YES- Next menu
1- Time/Date
2- Customer Name
3- Serial Number

Press **(YES)** two times for:

YES- Next menu
7- Erase Std Cts
8- Memory Clear
9- Burn-in

Press **(7)** for the display:

Press SHIFT/YES
to erase all
Standard Counts
in gauge?!

Press **(SHIFT)** and **(YES)** to erase all the standard counts. The display will return to the *Extended Functions* menu.

MEMORY CLEAR

The *Memory Clear* function is to be used by qualified service personnel only!



CAUTION

Executing the *Memory Clear* function will erase critical information that is necessary for gauge operation!

BURN-IN

The *Burn-In* function is to be used by qualified service personnel only!

CALIBRATION STANDARD

The *Calibration Standard* function allows the operator or service technician to input the factory calibration standard count.

To execute *Calibration Standard* function, press **<SHIFT>** and **<SPECIAL>** for:

SPECIAL FUNCTION
YES- Next menu
1- STAT TEST
2- DRIFT TEST

Press **<19>** to display:

EXTENDED
FUNCTIONS
Enter Code----
and Press ENTER

The *Access Code* must be entered. This code is for authorized personnel only. If you need assistance with the code, contact your nearest Troxler Representative.

Enter the code and press **<START/ENTER>**. The display will be:

YES- Next menu
1- Time/Date
2- Customer Name
3- Serial Number

Press **<YES>** three times for:

YES- Next menu
10- Calib. Std
11- Remote Cntrl

Press **<1>** **<0>** to display:

Calib. Standard
Count: x
Input and
Press ENTER

Input the calibration standard count and press **<START/ENTER>**.

The display will return to the *Extended Functions* menu.

REMOTE CONTROL

The *Remote Control* function is to be used by qualified service personnel only!

APPENDIX A

THEORY OF OPERATION

This appendix contains brief explanations of the principle of operation of the 3440 gauge. Backscatter mode and direct transmission mode are explained, as well as the theoretical differences between the density and moisture measurement technique.

CONTENTS

Density	A-2
Moisture	A-5

DENSITY

The Troxler Model 3440 Surface Moisture-Density Gauge uses two modes of operation: *direct transmission* mode (with the source rod extended) and *backscatter* mode (with the source rod placed in the first notch below the **SAFE** position).

In *direct transmission* mode (Figure A-1), the rod containing the cesium-137 source is lowered to the desired depth, resulting in gamma radiation emission. The detectors in the gauge base measure this radiation. Gamma photons reaching the detectors must pass through the full distance of soil, resulting in a large number of photons colliding with electrons present in the soil. These collisions reduce the number of photons that reach the detectors and thus allow the density of the material to be calculated. In short, the lower the number of photons reaching the detectors, the higher the density of the material. Since all of the photons arriving at the detectors have passed through the full distance from the source depth, the measured density is a true average for the material between the surface and the source.

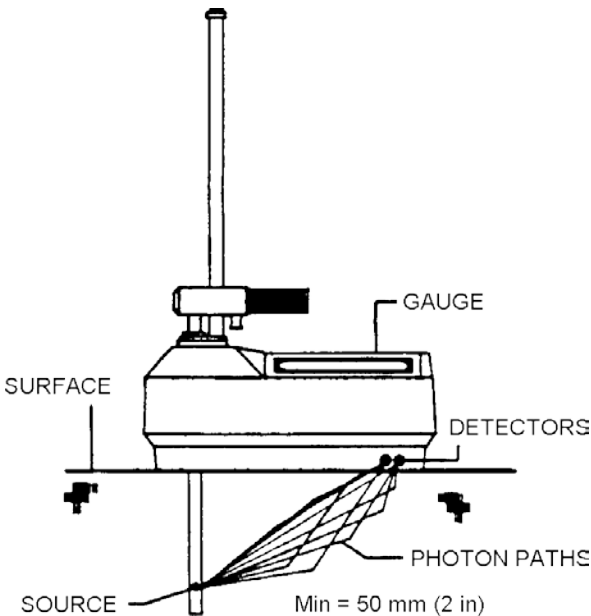

Figure A-1. Direct Transmission Geometry

In *backscatter* mode (Figure A-2), the gamma photons entering the material being measured must be scattered (or reflected) at least once to reach the detectors in the gauge. This result is achieved by leaving the source rod in a retracted position in the gauge. The rod is locked in the first position below the **SAFE** position, placing the source and detectors in the same horizontal plane. Under ideal conditions, no photons would reach the detector in a direct path from the source. However, this is not practical and the directly transmitted photons are generally held to 10% or less of the backscattered photons. Since no hole is required for the source rod, the backscatter mode is preferred for surfaces such as concrete and asphalt. However, since the photons have been scattered at least once, the average energy of the photons reaching the detectors is lower than the average energy of the photons in direct transmission conditions. This increases the possibility of error due to the effects of chemical composition. While the direct transmission geometry measures the average density from the source depth to the surface, the backscatter geometry yields an average that is heavily weighted by the surface density. Since the photon path length increases for photons passing through deeper material, this is a normal phenomena as most of the photons reaching the detectors will have passed through the surface material and have decreasing percentages through deeper materials.

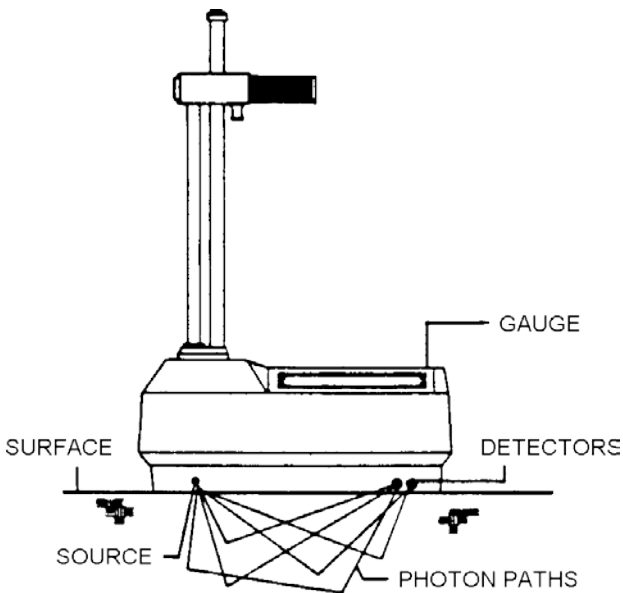

Figure A-2. Backscatter Geometry

A normalized curve showing the percentages of photons at the detectors for various depths is shown in Figure A-3. These curves can be used to compute the gauge response to layered materials of different densities. As an example, for a 20-mm thick material with a density of 2000 kg/m³ overlaying a material with a density of 2150 kg/m³, the gauge measurement will indicate a density of 2089 kg/m³ [(2000 x 0.41) + (2150 x 0.59)].

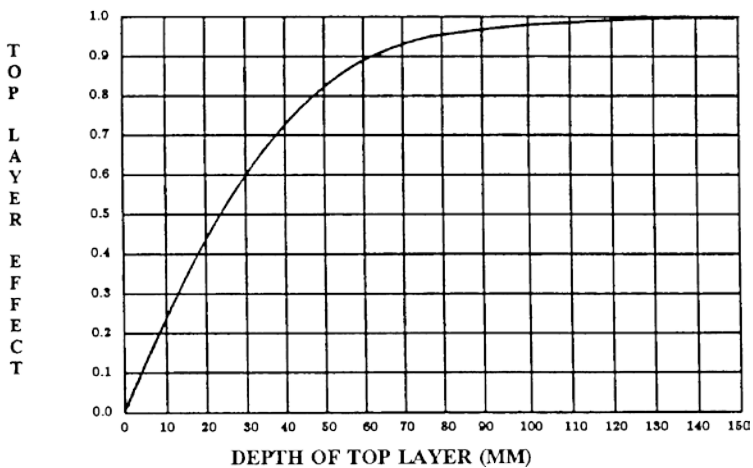
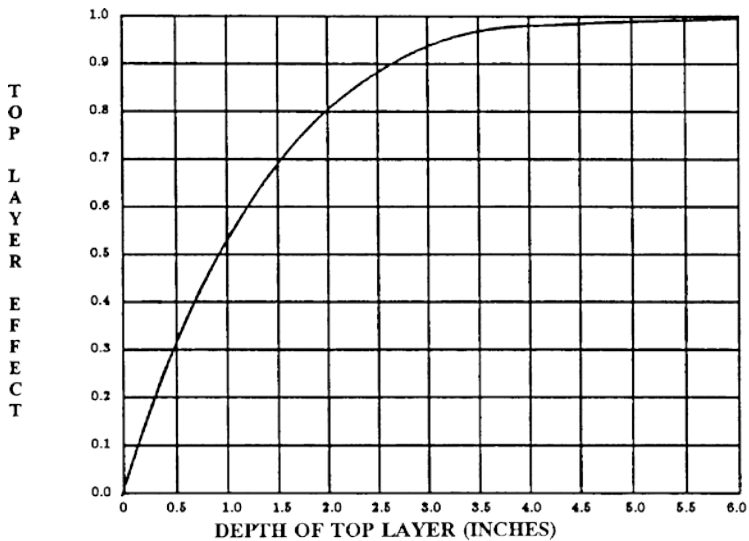

Figure A-3. Depth of Top Layer

MOISTURE

The 3440 gauge uses a 40mCi americium 241:beryllium source with a yield of 70,000 neutrons per second. The neutrons are used to measure the hydrogen (water) content of the material because hydrogen in the material will *thermalize* the neutrons.

Thermalization is the process whereby fast (or *epithermal*) neutrons emitted by the source are slowed to velocities where additional collisions with hydrogen or other molecules will not further slow the neutrons. Neutron thermalization requires an average of nineteen collisions with hydrogen nuclei. Other elements require a greater number of collisions for thermalization (Table A-1).

Due to their high sensitivity, the He-3 detectors in the 3440 gauge are very suitable for detection of thermalized neutrons. The He-3 tube is insensitive to fast neutrons and the counts obtained are directly proportional to the hydrogen/moisture content of the material.

Additionally, there are elements that absorb, or capture, neutrons into their nuclei. The extent to which neutrons interact with nuclei is described in terms of quantities known as *cross-sections*. The larger the cross-section, the greater the possibility of neutron capture or absorption. Boron, cadmium, and chlorine are elements that have large cross-sections and may cause problems when attempting to measure the moisture of materials containing these elements. An offset may be needed for the gauge if moisture measurements are required in these materials.

Depth of Measurement, or the depth below which no more than 2% of the counted neutrons pass before reaching the detector, is generally a function of the moisture content. The normalized curve set shown in Figure A-4 illustrates the effects of moisture content on the radius of measurement.

This function may be expressed by:

$$\text{Depth (in.)} = 11 - (0.17 \times M), \text{ where } M = \text{Moisture in } \text{pcf}$$

or

$$\text{Depth (mm)} = 280 - (0.27 \times M), \text{ where } M = \text{Moisture in } \text{kg/m}^3$$

Table A-1. Neutron Thermalization and Absorption Data

Element	Weight Fractions of Earth's Crust	Collisions to Thermalization	Thermal Absorption Cross Section
Hydrogen	0.0014	19.0	0.33
Boron	*	109.2	759.00
Carbon	*	120.6	0.0034
Nitrogen	*	139.5	1.90
Oxygen	0.466	158.5	0.002
Sodium	0.028	224.9	0.53
Magnesium	0.021	237.4	0.063
Aluminum	0.081	262.8	0.23
Silicon	0.277	273.3	0.16
Phosphorus	0.001	300.8	0.19
Sulfur	*	311.1	0.51
Chlorine	*	343.3	33.00
Potassium	0.026	378.0	2.10
Calcium	0.036	387.3	0.43
Titanium	0.004	461.6	6.10
Manganese	0.001	528.5	13.30
Iron	0.050	537.2	2.53
Cadmium	*	1074.6	2390.00
Lead	*	1975.5	0.17
Uranium	*	2268.6	4.20

* Weight fraction is less than 0.1%.

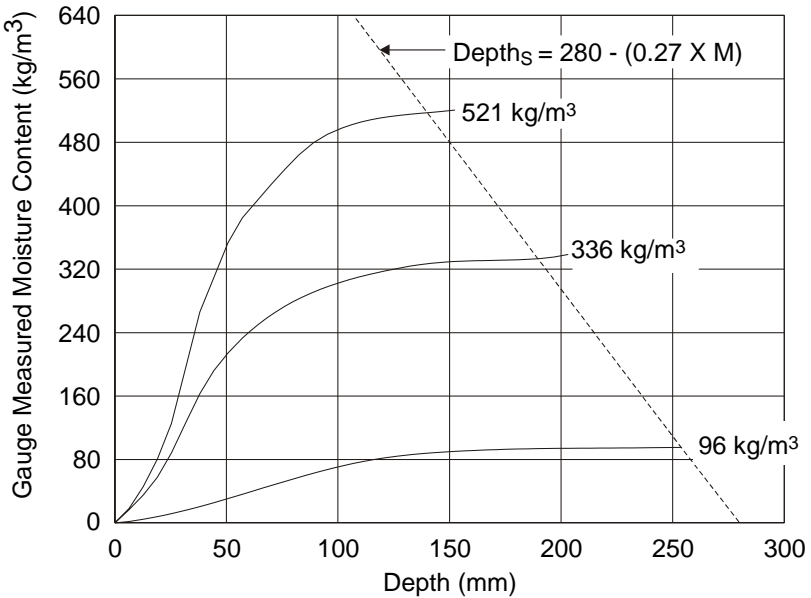
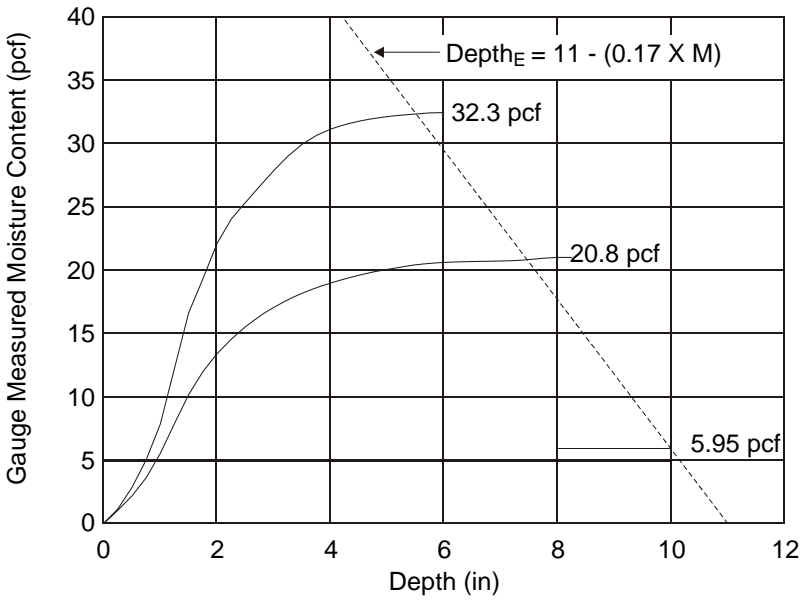

Figure A-4. Effect of Moisture on Depth of Measurement

NOTES

APPENDIX B

RADIATION THEORY

This appendix is required reading for anyone who will operate the 3440 nuclear system. This appendix covers radiation theory, along with a brief explanation of radiation statistics and radiation terminology.

CONTENTS

Atomic Structure B-2

Radiation Theory..... B-3

Radiation Statistics B-4

Radiation Terminology B-5

ATOMIC STRUCTURE

A more detailed discussion of radiological theory can be found in the *Troxler Nuclear Gauge Safety Training Program* manual, provided at the Troxler safety class.

All materials consist of chemical elements that can not decompose by ordinary chemical methods. Some examples are:

(H) Hydrogen (C) Carbon (O) Oxygen
(U) Uranium (Cf) Californium (Co) Cobalt

The fundamental component of an element is an atom with a unique structure (Figure B-1). The atom consists of smaller particles such as protons, neutrons, and electrons. The protons and neutrons are grouped together in the nucleus. The electrons orbit the nucleus. An atom is normally electrically neutral because the positive charges of the protons cancel out the negative charges of the electrons.

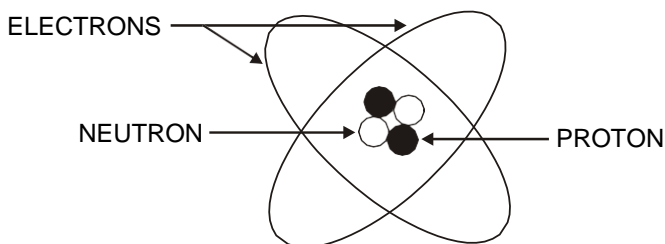

Figure B-1. Diagram of an Atom

Protons carry a positive charge and are described as having a mass of one. Neutrons have a neutral charge and also have a mass of one. Electrons carry a negative charge and essentially have no mass.

	MASS (ATOMIC WEIGHT SCALE)	CHARGE
Protons	1.0073	+1
Neutrons	1.0087	0
Electrons	0.0006	1

Since protons and neutrons are clustered together in the nucleus, the mass of an atom is concentrated in the nucleus. The atom in Figure B-1 has two protons and two neutrons; therefore, it is a helium atom. The atomic weight of an atom is the sum of the protons and neutrons.

RADIATION THEORY

Radioactivity is the spontaneous breakdown of unstable nuclei (radioisotopes) with the resulting emission of radiation. The basic unit of radiation used in the U.S.A. is the *curie* (Ci). The curie is defined as 3.7×10^{10} disintegrations of nuclei per second. In the “Special Form” encapsulated sealed sources used in the 3440 gauge, the unit of measure is the millicurie (1/1,000 of a curie). The SI unit of radiation is the *becquerel* (Bq). The becquerel equals one disintegration per second. Therefore, one curie equals 3.7×10^{10} becquerel.

The strength of radioactive material is measured by its activity, or rate of decay. This activity decreases with time. The length of time it takes a given amount of radioactive material to decay to half of its original strength is referred to as the *half-life*. The Am-241:Be source in the Model 3440 has a half-life of 432 years, while the half-life of the Cs-137 source is thirty years.

RADIATION STATISTICS

Radioactive emission is a random process. The number of emissions in a given time period is not constant but varies statistically about an average value. The variation in the number of emissions follows a Poisson distribution about the true mean value. In this distribution, the standard deviation (σ) about the mean (n) is defined as:

$$\sigma = \sqrt{n}.$$

When the mean is greater than 100, the Poisson distribution can be closely approximated by the normal distribution (Figure B-2). The normal distribution predicts the probability that any given count rate will fall within a selected region about the mean.

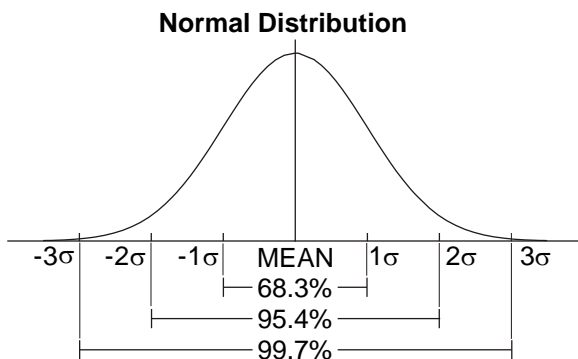

Figure B-2. Variation of Radioactive Emission

Using the mean of a larger number of counts to approximate the true mean, the distribution shows that 68.3% of the time the count rate obtained will be within ± 1 standard deviation of the mean. Figure B-2 shows the probabilities of counts falling within three standard deviations of the mean. The operator can perform a statistical stability test (stat test) to compare the experimental standard deviation to the theoretical standard deviation (see page 6-3).

RADIATION TERMINOLOGY

The *radiation absorbed dose*, or *rad*, is the unit of absorbed dose equal to 0.01 Joules/kg in any medium. To account for the effect of various types of radiation on biological tissue, the *roentgen equivalent man (rem)* or, more appropriate for Troxler operators, the *millirem (mrem)* is used when measuring radiation dose. The unit rem is derived from scaling the radiation absorbed dose (rad) by a quality factor (QF). One *rad* is equal to the exposure of one *rem* of photon radiation. For example, the average neutron energy of an americium-241:beryllium source is 4.5 MeV. The quality factor (QF) for this radiation is about 10. The absorbed dose of 1 rad of neutron radiation produces a dose equivalent of (absorbed dose x QF) 10 rem.

NOTES

APPENDIX C

RADIOLOGICAL SAFETY

This appendix is required reading for anyone who will operate the 3440 nuclear system. This appendix provides a brief discussion of general radiation safety. The exposure profile for the Model 3440 gauge is also included, along with a discussion of the source encapsulation.

CONTENTS

Radiation Types	C-2
Radiation Exposure	C-3
Monitoring Radiation	C-4
3440 Radiation Profile	C-4
Source Encapsulation	C-6
Emergency Procedures	C-6

C. RADIOLOGICAL SAFETY

RADIATION TYPES

The radioactive sources in the Model 3440 gauge produce four types of radiation:

- Alpha Particles
- Beta Particles
- Photons (Gamma Rays)
- Neutrons

The alpha and beta particles are stopped by the source capsule. Only the photon and neutron radiation contributes to any occupational radiation exposure.

Photon (gamma) radiation is electromagnetic radiation, as are x-rays, radio waves, and visible light. Visible light and photons have no mass or electrical charge, and travel at the speed of light. Photons are energetic and penetrating. Photons originate from the nucleus of the cesium-137 atom after radioactive decay. The number of photons emitted from a 3440 gauge is very low. Dense materials (i.e., lead, cadmium, etc.) provide the best shielding against photon radiation.

Neutron radiation allows measurement of the hydrogen (water) content in a material because the neutrons are slowed by collisions with materials containing hydrogen atoms (for example: water, polyethylene, etc.). Neutrons have no charge and are very penetrating.

RADIATION EXPOSURE

Government agencies set occupational exposure limits. The current limit in the United States and in many other countries is 5,000 mrem per year. Under average conditions, a full time employee working with the 3440 gauge will receive less than 200 mrem per year.

Taking advantage of all available means to limit radiation exposure is always recommended. The three methods of limiting exposure are:

TIME
DISTANCE
SHIELDING

These methods are a part of the *ALARA* (As Low As Reasonably Achievable) concept.

The simplest way to reduce exposure is to keep the *time* spent around radioactive source to a minimum. If time is cut in half, so is the exposure, with all other factors remaining constant.

Distance is another effective means to reduce radiation exposure. A formula known as the “inverse square law” relates the radiation exposure rate to distance (Figure C-1). Doubling the distance from a radiation source reduces the exposure to one-fourth its original value. If the distance is tripled, the exposure is reduced by a factor of nine, etc.

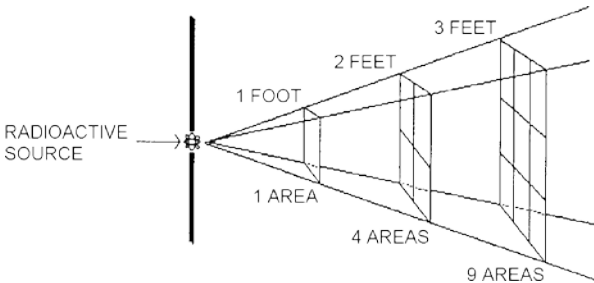

Figure C-1. Effect of Distance on Exposure

Shielding is any material used to reduce the radiation reaching the operator from a radioactive source. While some types of radiation such as alpha particles may be stopped by a single sheet of paper, other radiation such as photons and neutrons require much more shielding. Dense materials, such as lead, shield photons. Materials containing large amounts of hydrogen, such as polyethylene, shield neutrons. The Model 3440 has built-in shielding to reduce the exposure.

MONITORING RADIATION

In the United States, anyone working with or near radioactive materials is subject to the limits on occupational exposure mentioned earlier and must complete a radiation safety training course to be designated an authorized operator. An individual designated as an authorized operator must work in a “controlled” environment to the extent that their exposure to radiation must be monitored. Several means of personnel monitoring or *dosimetry* exist; the most common methods are film badges and thermoluminescent dosimeter (TLD) badges.

In Canada, nuclear gauge operators are not normally classified as Atomic Radiation Workers. In such cases, the general public dose limit of 0.5 rem/yr. would apply. Operators may not be required to wear a dosimeter. To establish the personnel monitoring requirements for your application, consult the conditions of your radioisotope license and the Atomic Energy Control Board regulatory document R91 “Monitoring and Dose Recording for the Individual”.

3440 RADIATION PROFILE

Table C-1 shows the radiation profile for the 3440 gauge. The table lists the radiation dose equivalent rates (in mrem/hour) for each side of the gauge and transport case shown in Figure C-2.

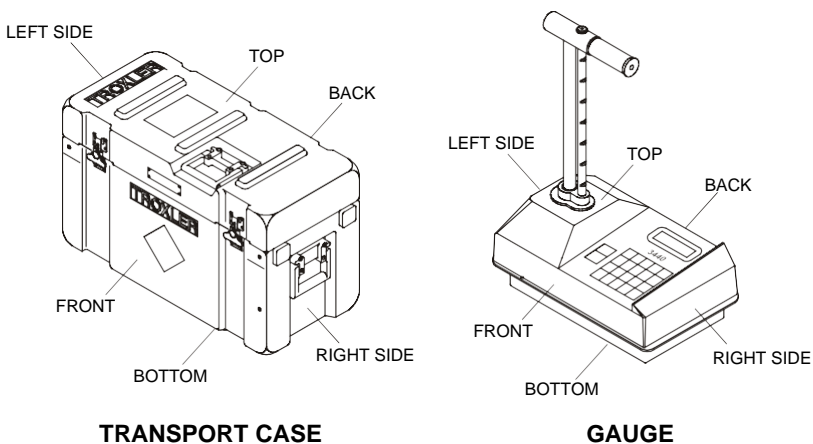

Figure C-2. 3440 Gauge and Transport Case

Table C-1. Radiation Dose Equivalent Rates in Millirems per Hours

	SURFACE			10 CENTIMETERS			30 CENTIMETERS			1 METER		
	Gamma	Neutron	Total	Gamma	Neutron	Total	Gamma	Neutron	Total	Gamma	Neutron	Total
GAUGE												
Front	19.0	1.5	20.5	5.0	0.5	5.5	1.2	0.2	1.4	0.3	0.1	0.4
Back	18.0	0.8	18.8	6.0	0.4	6.4	1.5	0.2	1.7	0.2	0.1	0.3
Left Side	13.0	0.4	13.4	3.0	0.2	3.2	0.8	0.1	0.9	0.1	0.1	0.2
Right Side	12.0	0.6	12.6	6.0	0.3	6.3	3.0	0.2	3.2	0.5	0.15	0.65
Top	19.0	0.9	19.9	3.5	0.6	4.1	0.6	0.4	1.0	0.15	0.1	0.25
Bottom	18.0	1.9	19.9	4.0	1.2	5.2	0.7	0.4	1.1	*	0.1	0.1
TRANSPORT CASE WITH GAUGE												
Front	8.0	0.3	8.3	3.0	0.25	3.25	1.1	0.15	1.25	0.3	*	0.3
Back	7.0	0.3	7.3	3.0	0.2	3.2	1.0	0.1	1.1	0.2	*	0.2
Left Side	0.4	0.1	0.5	0.3	*	0.3	0.2	*	0.2	0.2	*	0.2
Right Side	6.0	1.4	7.4	2.0	0.7	2.7	0.6	0.25	0.85	0.2	0.1	0.3
Top	13.0	0.2	13.2	3.0	0.15	3.15	0.9	*	0.9	0.3	*	0.3
Bottom	8.0	0.3	8.3	4.0	0.1	4.1	2.5	0.1	2.6	0.6	*	0.6

C. RADIOLOGICAL SAFETY

NOTES:

1. Dose rates measured by the State of North Carolina Department of Environment, Health, and Natural Resources, Division of Radiation Protection.
2. All values in mrem/hr.
3. Indicates a reading of less than 0.1 mrem/hr.
4. Dose equivalent rates for 0.3 GBq (8 mCi) Cs-137 gamma source and 1.48 GBq (40 mCi) Am-241:Be neutron source
5. Surface indicates surface of gauge or surface of transport case.
6. Gamma measurements made with *Ludlum Model 14C Survey Meter*, calibrated September 1987.
7. Neutron measurements made with *Nuclear Research Corporation Model NP-2 Survey Meter*, calibrated March 1988.

SOURCE ENCAPSULATION

The source in the 3440 gauge meets regulatory requirements of U.S. and international authorities as “Special Form” sealed source material. The sealed sources used are encapsulated to prevent leakage of the radioactive material and meet radiation safety requirements.

The neutron (americium-241:beryllium) and photon (cesium-137) sources are compressed and welded inside stainless steel capsules.

Proper use of this instrument (following the instructions in this manual) and the shielding design of the instrument will keep the exposure levels at a minimum under normal conditions. The operator, however, may be required to wear personnel dosimetry when using the 3440.

EMERGENCY PROCEDURES

If the nuclear gauge is lost or stolen, immediately notify the Radiation Safety Officer (RSO).

The gauge owner should complete the emergency contact information on the lines furnished below:

The company RSO is _____

Call the RSO at _____

The regulatory agency is _____

Call the agency at _____

If a gauge is damaged, then follow the steps below:

- ✓ Locate the gauge and/or source.
- ✓ Do not touch or move the gauge.
- ✓ Immediately cordon off an area around the nuclear gauge and/or source. A radius of 15 ft (5 m) will be sufficient. Do not leave the area unattended.
- ✓ Keep all unauthorized personnel away from the nuclear gauge.

- ✓ If a vehicle is involved, it must be stopped until the extent of contamination, if any, can be established.
- ✓ The gauge operator should perform a visual inspection of the nuclear gauge to determine if the source housing and/or shielding has been damaged.
- ✓ Use a survey meter to measure the dose rate at a distance of 3 ft (1 m) from the gauge.
- ✓ Contact the company RSO (name and number given at the beginning of this section). Provide the RSO with the following:
 - ◆ The date, time, and location of the accident
 - ◆ The gauge model and serial number
 - ◆ The nature of the accident
 - ◆ The location and condition of the gauge and/or source
 - ◆ The dose rate at 3 ft (1 m) from the gauge
- ✓ If you are unable to reach the RSO, then call your regulatory agency (name and number given at the beginning of this section).
- ✓ Follow the instructions of the RSO. The RSO may be required to report the incident to the regulatory agency. The RSO may also be required to notify the USDOT of accidents during transport.
- ✓ Take a picture of the gauge. Perform a leak test and send the leak test wipe to Troxler for analysis. The Troxler RSO will contact you and give you an RGA (returned goods authorization). Do not ship a damaged gauge to Troxler without an RGA.

NOTES

APPENDIX D

LICENSING REQUIREMENTS

This licensing requirements outlined in this appendix apply to all Troxler gauge operators in the United States. Operators of Troxler products outside the U.S. should contact the Troxler International, Ltd. representative in their area or the factory for more information on regulatory requirements.

CONTENTS

Specific License	D-2
Radiation Safety Program	D-2
Personnel Monitoring.....	D-2
Security	D-2
Training.....	D-3
Leak Test.....	D-3
Notice to Employees	D-3
Incidents.....	D-3
Disposal.....	D-4
Record Keeping.....	D-4

SPECIFIC LICENSE

Possession and use of the radioactive material found in a nuclear gauge requires the operator to maintain a specific license issued by the United States Nuclear Regulatory Commission or equivalent agreement state licensing agency. Troxler Electronic Laboratories, Inc. will provide assistance and information for obtaining the necessary license.

RADIATION SAFETY PROGRAM

The specific license dictates that nuclear gauge operators maintain control of the gauge in a manner to minimize radiation exposure to operators and the general public. To determine the requirements applicable to your operation, review both your licensing documents and the radiation safety procedures accompanying your license application. The following requirements are generally accepted by all licensing agencies in the U.S.

PERSONNEL MONITORING

Most licensing agencies do require personnel monitoring devices to be worn by nuclear gauge operators. These devices record the actual radiation to which the operator is exposed while operating the equipment. When the equipment is not in use, the personnel monitoring device should be kept in a radiation free area. The reports of radiation exposure supplied by the personnel monitoring service must be maintained on file and available for review by employees and the licensing agency. Contact Troxler or their appointed representative for help in obtaining personnel monitoring devices or radiation monitoring equipment.

SECURITY

Regulations further require that operators provide all necessary security to prevent unauthorized use or removal of the gauge when in storage or in transit. The transport case can be locked. A lock may be obtained from Troxler (Part Number 12176). The gauge is supplied with a lock to secure the source rod in the SAFE, shielded position.

TRAINING

Troxler Electronic Laboratories, Inc. continues to provide a one-day training seminar for nuclear gauge operators and individuals designated as Radiation Safety Officers. This class provides radiological physics familiarization and instruction in the safety procedures required to operate a nuclear gauge. Operators outside the U.S. should contact their Troxler representative for training and assistance.

LEAK TEST

Unless specified otherwise by your radioactive material license, the gauge must be leak tested at intervals not exceeding 12 months to ensure the integrity of the radioactive sources contained in the gauge. First, make sure the source rod is locked into the storage, or **SAFE**, position. Using the Troxler Model 3880 Leak Test Kit and accompanying instructions, remove the control panel from the gauge front. Looking down into the gauge interior locate the yellow radiation label in the middle of the gauge base and on the top of the circuit board. Wipe the yellow label with the wipe disk, using the tongs to hold the disk. Next, turn the gauge on one side and locate the opening through which the source rod would protrude when indexing. Wipe around and into this opening. Pack the disk, as instructed, in the envelope and mail to Troxler Electronic Laboratories, Inc. for analysis. Reassemble the gauge and secure properly.

NOTICE TO EMPLOYEES

Figure D-1 on page D-6 is a reduced example of a “NOTICE TO EMPLOYEES” (supplied by your licensing agency) that must be posted where employees that use the gauge and others who may enter the gauge storage area can see it. This notice must also be posted wherever and whenever temporary gauge storage is necessary (in a trailer on the job site, etc.). It is not required (or advisable) to post the notice on the outside of any structure where it may be viewed by the general public.

INCIDENTS

If the gauge is removed from the custody of the licensee (i.e., lost, stolen, etc.) or physically damaged to the extent that the source or shielding may be or is compromised (open or danger), **the licensee must notify the licensing agency immediately**. Call Troxler or your appointed representative for further advice or assistance.

DISPOSAL

Regulations require that very strict methods be followed when disposing of radioactive materials. For specific information concerning disposal costs and available disposal sites, please contact the factory or your local Troxler representative if outside of the United States. Generally, a Troxler gauge may be transferred to another authorized licensee or returned to our factory for final disposal.

RECORD KEEPING

In the United States, the following documentation should be maintained and available for review by the licensing agency. (Outside the United States, refer to your local licensing authority/agency or contact your authorized Troxler representative).

1. **Radioactive Material License.** A valid license must be on file and should be periodically reviewed to ensure that all conditions are current.
2. **Troxler Training Certificate.** A certificate of attendance at a Troxler Training Course is required by each operator.
3. **Regulations.** A copy of the regulations furnished by your licensing agency should be maintained as part of your records.
4. **Leak Test Report.** As a means of verification of compliance with current regulations, a copy of each Leak Test Report for each gauge in your possession must be on file. (It is also a good idea to make a note when Leak Tests are performed and sent. If you are inspected before test results are returned, you have de facto (existing) proof of compliance.)
5. **Personnel Monitoring Report.** A copy of each personnel monitoring report must be maintained in your files. This report must contain the wearer's name, social security number, date of birth, and actual exposure received.
6. **Inventory, Receipt, and Transfer Records.** A log to show gauge location should be maintained. Whenever a gauge is removed from a permanent to a temporary location, it should be noted on the log. When removed from a temporary site, a log should show where the gauge is being used. Operators should be required to sign out when removing gauges and sign in when returning them. The licensee is required to know where each gauge is at all times.

7. **Gauge Certificate**. New gauges are shipped with a gauge certificate denoting the radioactive material used in the gauge. The original gauge certificate should be on file and a copy carried with the gauge at all times.
8. **Transport Package Certification**. The regulations require that each shipper of a (Specification 7A) Type A package “must maintain on file for at least one year after the latest shipment” testing methods and results for the Type A package. Troxler has provided this document, entitled “Testing Results for Type A Package for the 3440...” with the 3440 documentation.
9. **Transportation – Bill of Lading**. U.S. DOT regulations require properly prepared shipping documents when transporting a gauge (see Appendix E).
10. **Emergency Procedures**. The telephone number of the licensing agency and procedures for reporting incidents should be kept on file for the convenience of concerned personnel.
11. **Notice to Employees Poster**. A copy of this notice should be on file. A facsimile of this notice is on page D–6. For display requirements, see the *Notice to Employees* section on page D–3.

NOTICE TO EMPLOYEES

STANDARDS FOR PROTECTION AGAINST RADIATION (PART 20), NOTICES, INSTRUCTIONS AND REPORTS TO WORKERS, INSPECTIONS (PART 19), EMPLOYEE PROTECTION



WHAT IS THE NUCLEAR REGULATORY COMMISSION?
The Nuclear Regulatory Commission is an independent Federal regulatory agency responsible for the safety, health and environmental protection of the Nation's nuclear power plants and other nuclear activities.

WHAT DOES THE NRC DO?
The NRC's primary responsibility is to ensure the safety and health of the Nation's nuclear power plants and other nuclear activities. The NRC also ensures the safety and health of the Nation's nuclear workers and the public. The NRC's primary responsibility is to ensure the safety and health of the Nation's nuclear power plants and other nuclear activities.

WHAT RESPONSIBILITY DOES MY EMPLOYER HAVE?
Your employer must follow NRC rules to ensure the safety and health of your workers and the public. The NRC's primary responsibility is to ensure the safety and health of the Nation's nuclear power plants and other nuclear activities.

WHAT IS MY RESPONSIBILITY?
You must follow NRC rules to ensure the safety and health of your workers and the public. The NRC's primary responsibility is to ensure the safety and health of the Nation's nuclear power plants and other nuclear activities.

WHAT IS A CAUSE AND EFFECT?
A cause is an action or event that leads to an effect. The NRC's primary responsibility is to ensure the safety and health of the Nation's nuclear power plants and other nuclear activities.

HOW DO I REPORT VIOLATIONS AND SAFETY CONCERNS?
If you observe a violation of NRC rules, you should report it immediately to your supervisor or the NRC. The NRC's primary responsibility is to ensure the safety and health of the Nation's nuclear power plants and other nuclear activities.

MAY I REQUEST AN INSPECTION?
If you believe there is a safety concern, you may request an inspection. The NRC's primary responsibility is to ensure the safety and health of the Nation's nuclear power plants and other nuclear activities.

WHAT CAN THE DEPARTMENT OF LABOR DO?
The Department of Labor enforces the Fair Labor Standards Act (FLSA). The NRC's primary responsibility is to ensure the safety and health of the Nation's nuclear power plants and other nuclear activities.

WHAT FORMS OF DISCRIMINATION ARE PROHIBITED?
The NRC prohibits discrimination based on race, color, religion, sex, or national origin. The NRC's primary responsibility is to ensure the safety and health of the Nation's nuclear power plants and other nuclear activities.

WHAT TALK WITH AN NRC INSPECTOR?
If an NRC inspector visits your facility, you should cooperate fully. The NRC's primary responsibility is to ensure the safety and health of the Nation's nuclear power plants and other nuclear activities.

HOW DO I FILE A DISCRIMINATION COMPLAINT?
If you believe you have been discriminated against, you may file a complaint with the EEOC. The NRC's primary responsibility is to ensure the safety and health of the Nation's nuclear power plants and other nuclear activities.

WHAT IS THE NRC'S POLICY ON SAFETY?
The NRC's primary responsibility is to ensure the safety and health of the Nation's nuclear power plants and other nuclear activities.

WHAT ARE THE NRC'S SAFETY STANDARDS?
The NRC has established safety standards for nuclear power plants and other nuclear activities. The NRC's primary responsibility is to ensure the safety and health of the Nation's nuclear power plants and other nuclear activities.

WHAT ARE THE NRC'S INSPECTION PROCEDURES?
The NRC uses various inspection procedures to ensure the safety and health of the Nation's nuclear power plants and other nuclear activities.



4. Chambers Field Site, Missouri and Grand Gulf Plant Site in Mississippi are under the purview of Region V. The Palo Verde Plant in Florida is primarily under the purview of Region III.

UNITED STATES NUCLEAR REGULATORY COMMISSION REGIONAL OFFICE LOCATIONS

A representative of the NRC Regional Office Commission can be contacted by employees who wish to register complaints about radiological working conditions or other matters regarding compliance with Commission rules and regulations at the following addresses and telephone numbers:

REGION	ADDRESS	TELEPHONE
I	U.S. Nuclear Regulatory Commission, Region I 475 Annapolis Blvd., Suite 1415 Annapolis, MD 21403	(800) 432-1156
II	U.S. Nuclear Regulatory Commission, Region II 4101 Peachtree Street, N.E., Suite 2175 Atlanta, Georgia 30341	(800) 577-6510
III	U.S. Nuclear Regulatory Commission, Region III 801 Alameda Road Berkeley, CA 94702	(800) 522-3025
IV	U.S. Nuclear Regulatory Commission, Region IV 611 East Main Street, Suite 600 Chicago, IL 60601	(800) 952-9677
V	U.S. Nuclear Regulatory Commission 1001 N. 1st Street, Suite 100 Portland, OR 97208	(800) 882-4672

To report incidents involving
hazard waste or abuse
by an NRC employee
or NRC contractor,
contact:
HOTLINE
1-800-233-3497

To report safety concerns or
NRC requirements
by your employer,
contact:
NRC
SAFETY HOTLINE
1-800-695-7403

Figure D-1. Sample Notice to Employees



APPENDIX E

TRANSPORTATION AND SHIPPING

Devices containing radioactive materials must be transported in accordance with the rules of the U.S. Department of Transportation (DOT) and the International Atomic Energy Agency (IAEA). The IAEA recommendations have been codified in the International Air Transport Association (IATA) Dangerous Goods Regulations. International customers should consult their local government or licensing authority for applicable regulations.

CONTENTS

U.S. Requirements	E-2
Accident Notification Requirements	E-3
Hazmat Training	E-3
Canadian Shipping Requirements	E-4

U.S. REQUIREMENTS

The U.S. DOT hazmat regulations (49 CFR, Parts 100–185) apply any time a nuclear device is transported by motor vehicle on a public highway or by other means of transport (rail, air, ship).

The major requirements for transporting a nuclear gauge in the United States are listed below. For more detailed information about these requirements, please refer to the *Troxler Transportation Guide*.

- ◆ A copy of the current IAEA Certificate of Competent Authority for each source in the gauge (Special Form Certificate) must be kept on file. Current versions can be downloaded from the Troxler website, www.troxlerlabs.com.
- ◆ A copy of the results of the Type A package testing must be kept on file.
- ◆ Hazmat employee training records must be kept on file.
- ◆ An *Emergency Response Information* document must be in the vehicle and immediately accessible to the driver.
- ◆ A properly completed bill of lading must be in the vehicle and immediately accessible to the driver. The shipping papers must include a 24-hr emergency response phone number.
- ◆ If shipping by air, a *Shipper's Declaration for Dangerous Goods* must accompany the air waybill.
- ◆ The package must be properly marked and labeled in accordance with hazmat regulations.
- ◆ The package must have a tamper-evident seal.
- ◆ The package must be inspected prior to each shipment.
- ◆ The package must be securely blocked and braced in the vehicle to prevent shifting during transport.

ACCIDENT NOTIFICATION REQUIREMENTS

In the event of a reportable incident involving radioactive material, notify the licensing agency as soon as practical. The operator is also required to notify, at the earliest practical moment, the U.S. DOT at 1-800-424-8802 of an accident that occurs during the course of transportation (including loading, unloading, and temporary storage) in which fire, breakage, spillage, or suspected contamination occurs involving shipment of radioactive materials.

HAZMAT TRAINING

The U.S. DOT regulations require every hazmat employer to train, test, certify, and maintain records for each hazmat employee. Hazmat training applies to anyone who transports or prepares for transport radioactive materials. Refresher training is required every three years.

CANADIAN SHIPPING REQUIREMENTS

The *Transportation of Dangerous Goods Act and Regulations* (TDG) and *Transport Packaging of Radioactive Materials Regulations* (TPRM) apply any time a nuclear device used in commerce is transported by any means in Canada.

For training and accident notification requirements, consult the *Transportation Of Dangerous Goods Regulations*. For further information on transporting a nuclear device, contact the transportation section of The Canadian Nuclear Safety Commission (CNSC).

APPENDIX F

PERIODIC MAINTENANCE AND SERVICE

This appendix contains important information for maintaining and servicing the 3440 Surface Moisture-Density Gauge. The following procedures should be performed to keep the 3440 gauge in working order. In the event that a serious problem with the gauge arises, contact your nearest Troxler Service Center or Troxler representative for instructions.

CONTENTS

Batteries F-2
 Alkaline Battery Use F-2

Mechanical Maintenance..... F-4
 Sources F-4
 Inspecting Source Rod F-4
 Cleaning the Tungsten Sliding Block..... F-4
 Scraper Ring/Tungsten Sliding Block Maintenance F-5
 Gaskets..... F-7
 3440 Gauge Top Shell..... F-8

Electronic Maintenance..... F-9
 3440 Baseboard Assembly..... F-9
 Troubleshooting F-10
 Possible Malfunction Indicators..... F-14
 Error Messages..... F-15

Replacement Parts F-16
 Accessories F-26
 Optional Accessories..... F-26
 Maintenance Supplies F-26

Returning a Gauge for Service F-27

BATTERIES

The 3440 gauge constantly updates the battery condition. Depending on operator preference, either the hours remaining or the battery voltage will be displayed. A fully charged battery will last approximately eight weeks under normal working conditions (eight-hour days) before recharging is necessary.

A low battery condition is indicated by the following display:

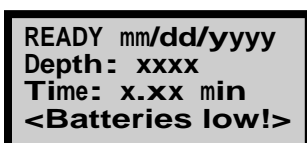

READY mm/dd/yyyy
Depth: xxxx
Time: x.xx min
<Batteries low!>

When this display appears, the battery must be recharged within a few hours. For best results, perform a full recharge with the ac charger. To access the charger port, unscrew the two captive screws that attach the black access cover to the front panel. Plug the charger into the round plug under the access cover. Plug the other end of the charger into a standard 110 V ac wall outlet. For a full charge, recharge the gauge for at least sixteen hours.

If necessary, for emergency use, a 30-minute recharge with the dc or ac charger provides several hours of use. After a short recharge time, the battery life display may not always indicate an accurate update of the battery-life. *Only a full sixteen-hour recharge will reset the battery life indicator.*

NOTE

For more information on updating or resetting the battery monitor, refer to page 6–27.

Although batteries cannot be “overcharged”, rechargeable batteries have a memory and repeated needless charging will shorten the battery life. Do not recharge batteries unless the battery indicator signals a low battery.

ALKALINE BATTERY USE

If recharging is not an option, alkaline batteries may be used. An accessory battery case assembly (PN 104148) is available as an option.



CAUTION

Do not mix alkaline and rechargeable batteries in the gauge. Charging may cause alkaline batteries to explode!

For Serial Numbers Below 21675

For gauge serial numbers below 21675, the High Voltage Module must be discharged before replacing the battery packs, as described in the following paragraphs.

To replace the battery packs, first turn the gauge off. Remove the display panel assembly and unplug it from the gauge. **Press the high voltage discharge switch located on the baseboard.** The battery leads are red and black, and are connected to white plugs on the left side of the baseboard. Unplug both battery leads **and** the depth indicator strip's clear leads in order to prevent possible damage.

Remove the screws holding the battery packs in place and slide the packs toward the baseboard. Lift out the battery packs and replace with the alkaline packs. Reverse the procedure for connecting all the leads and reinstalling the display panel. **Remember to plug the depth indicator strip leads and battery packs back in.**

For Serial Numbers 21675 and Above

For gauge serial numbers 21675 and above, there is no longer a need to discharge any high voltage.

To replace the battery packs, first turn the gauge off. Then, remove the display panel assembly by loosening the four captive screws on the display panel. Third, disconnect the ribbon cable from the baseboard. The ribbon cable connection is a locking release. To disconnect, pull the levers on either side of the ribbon down. After disconnecting the ribbon cable, remove the four screws that attach the top shell to the gauge base and suspend the top shell from the handle.

After noting the polarity of the connections, disconnect the battery packs (located on either side of the post). The connectors are white plugs with red and black wires. Remove the battery pack screws closest to the baseboard (right) for each battery pack. To remove each battery pack, slide the pack forward and lift up.

Replace each battery pack by sliding a new pack beneath the left screw and washer. Replace the right screw for each battery pack. With the same polarity as noted previously, connect the battery packs to the baseboard. Replace the top shell. **Be careful not to over-tighten the screws. Also, be sure to tighten them evenly to prevent warping of the top shell. Reconnect the ribbon cable to the baseboard assembly and replace the front panel assembly.**

MECHANICAL MAINTENANCE

SOURCES

The 3440 gauge contains two radioactive sources. The americium-241:beryllium source in the center of the gauge base is small and shielding is not required. Never attempt to remove this source. The Cs-137 source is welded inside the tip of the source rod. In the **SAFE** or shielded position, the Cs-137 source is surrounded by tungsten, reducing the radiation to safe levels.

INSPECTING SOURCE ROD

To ensure the integrity of the source rod, Troxler recommends that a qualified Troxler service person inspect the gauge and the source rod at least every five years. This inspection includes checking for wear, corrosion, or damage that could affect the safety of gauge operation.

CLEANING THE TUNGSTEN SLIDING BLOCK

If the sliding block is not kept clean, it may stick partially or completely open when the source rod is raised to the **SAFE** (shielded) position. This will result in high radiation levels near or in line with the source rod opening on the bottom of the gauge. After cleaning and re-assembling the gauge, check the operation of the sliding block by pushing the source rod into the backscatter position and then raising it back to the shielded position. You should hear a click as the sliding block snaps shut. Inspect the opening on the base of the gauge to confirm that the sliding block is completely closed. If not, check that the spring was properly reinstalled after cleaning. If the sliding block still does not close completely, contact your nearest Troxler Service Center immediately.



WARNING

Do not store or transport the gauge unless the sliding block is completely closed. Increased radiation levels may violate transportation regulations, and may cause excessive personnel radiation exposure.

SCRAPER RING/TUNGSTEN SLIDING BLOCK MAINTENANCE



Maintenance of the scraper ring or tungsten sliding block may be required if the following problems are encountered while using the gauge:

- ◆ Difficulty in lowering or raising the source rod (may indicate a need to replace the scraper ring).
- ◆ No “click” is heard from the tungsten sliding block striking the back of the shield cavity when the source rod is raised to the “safe” position.
- ◆ Erratic or incorrect density standard counts.



WARNING

Routine maintenance to clean the cavity beneath the source requires removal of the bottom sliding block. ALWAYS wear safety glasses and a dosimeter.

Procedure – Scraper Ring/Tungsten Sliding Block Maintenance

1. With the source rod in the **SAFE** position, place gauge on its side.
2. Clean the heads of the four screws to make removal easier and to prevent the screw heads from stripping.
3. Using a screwdriver, remove the bottom plate. Replace if excessive wear is evident on the back of the bottom plate.
4. If a large amount of dirt has accumulated on the backside of the bottom plate, the scraper ring has become excessively worn and should be replaced. Replace the scraper ring by first removing the retaining ring with a small screwdriver or scribe (Figure F-1). Carefully remove the scraper ring. Clean the entire plate of any debris. Install the new scraper ring and replace the retaining ring.

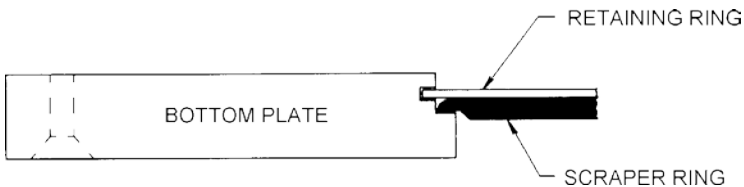



Figure F-1. Retaining and Scraper Rings

5. Remove the sliding tungsten shield. To reduce exposure when removing the shield, Troxler recommends that the operator stand to the side of the gauge. With a steel brush or rag, remove as much dirt as possible from the cavity.
6. Clean the sliding tungsten block. Replace the sliding block with the angled side up. If installed incorrectly, the source rod will not extend into the measurement position.
7. Apply a light coating of Magnalube-G→ paste to the top angled surface of the block. Do not grease any other surfaces on the sliding block or in the sliding block area. Remove any excess lubricant.
-  8. Replace the bottom plate. **Do not over-tighten screws in the aluminum base.** Ensure that the source rod moves up and down freely.

Procedure – Source Rod Bearing Maintenance

If the source rod does not slide up and down freely, the source rod bearing may require lubrication and cleaning. Lubricate the source rod bearing with Magnalube-G paste.

NOTE

Troxler Electronic Laboratories, Inc. assumes no responsibility for bearing life if lubricants other than Magnalube-G are used.

1. Carefully remove the gauge top shell by first removing the four 7/64-inch head screws. Tie the top shell to the source/index rod.
2. To catch any grease, place a rag or cloth under the vent valve located below the grease fitting on the source rod tower.
3. Using a standard 16-oz. grease gun with a Magnalube-G cartridge, apply five shots of lubricant or until all dirty grease is ejected from the vent valve and clean grease is visible.

NOTE

The vent valve was not installed on earlier gauges. Instead, an Allen-head screw was located below the grease fitting. On these gauges, remove the Allen-head screw before applying lubricant to allow the old grease to be ejected. Failure to remove the Allen-head screw may result in severe mechanical damage to the base assembly.

4. Remove any grease that was ejected. Reseat the top shell taking care to properly seat the post gasket and replace the screws. Do not over-tighten the screws.

GASKETS

Four gaskets seal the gauge from the environment. If the gauge has been out in extremely wet or humid weather, or was used in a cold environment and stored in a heated space, condensation may form on the inside of the gauge. Normally, this is not a problem and the condensation will dissipate overnight.

However, after using the gauge in any of the above conditions, it is recommended that the display panel be removed to allow air to circulate inside the gauge. Placing the gauge in a humidity-controlled or air-conditioned room and loosening the display panel screws will allow the gauge to “breathe”, reducing any moisture accumulation. A hair dryer (on low heat) may also be used to dry out the inside of the gauge.



CAUTION

High moisture levels inside the gauge may result in damage to the electronics, as well as erratic or fluctuating moisture readings.

NOTE

All gaskets may be replaced without removing the sources from the gauge.

To replace the control panel gasket, loosen the four screws and remove the control panel. Use care in handling the panel, trying not to touch the back of the circuit board. Unplug the connector from the keypad/display and remove the panel completely. Remove the old gasket and install a new gasket. Reassemble the connectors and panel.

To replace the two post gaskets and the top shell gasket, remove the four screws that hold the top shell to the base. Lift up the base, remove the gasket in question, and replace with a new gasket. A light coating of talcum powder on the inside of the post gasket will aid in re-assembly.

3440 GAUGE TOP SHELL

Currently, the 3440 gauge top shell is manufactured from an engineering thermoplastic designed specifically to provide high impact strength and to offer excellent compatibility with many industrial solvents and petrochemicals. The top shell may be cleaned with mild (low alkaline) soap and water. Other approved cleaning substances include: methyl, isopropyl, or isobutyl alcohols. A cloth dampened with kerosene or diesel fuel may be used to remove heavy soils. **Avoid prolonged exposure and do not soak.**



CAUTION

The use of any unapproved cleaning agents such as methyl-ethyl-ketones, amines, and methylene chloride will damage the top shell and void the warranty.

NOTE

In the past, the top shell was not compatible with petrochemicals. Your top shell is compatible with petrochemicals only if, upon removal of the keypad, there is a ridge around the exposed opening. If not, use only a mild soap (such as 409□ or Fantastic□) or alcohols (such as methyl or isopropyl) to clean the top shell.

ELECTRONIC MAINTENANCE



CAUTION

To avoid electrical shock and/or damage to the 3440 gauge components, turn off the gauge before servicing any electronic component.



NOTE

Electronic maintenance is to be done by Troxler Qualified Service personnel only. See page F-27 for information on returning a gauge to Troxler.

3440 BASEBOARD ASSEMBLY

Figure F-2 shows the 3440 baseboard assembly with any parts requiring general electronic maintenance labeled for the operator's reference.

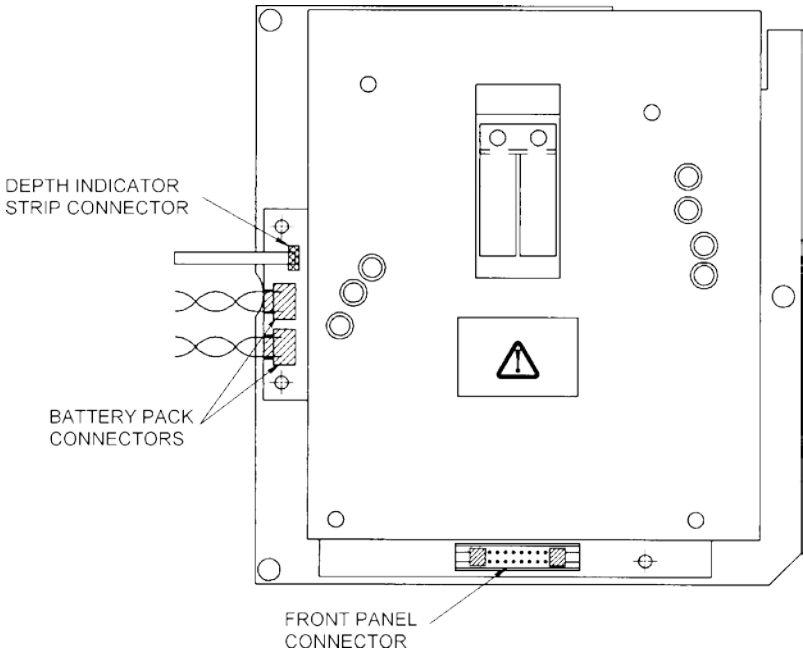

Figure F-2. 3440 Baseboard Assembly

TROUBLESHOOTING

GAUGE FAILS STANDARD COUNTS

- ✓ Ensure that the source rod opening on the gauge bottom is completely closed or covered by the tungsten sliding block. If any opening is visible, the sliding block should be cleaned. If the sliding block still does not close completely, contact the nearest Troxler Service Center.

NO DENSITY READING

- ✓ The most likely reason for no density readings is an electronic problem, such as a failure of the detector preamplifier. However, as a precaution, ensure that the tip of the source rod is intact and undamaged (that is, the source is not missing). This can be done by checking the radiation levels at the gauge base surface with a radiation survey meter (without extending the source rod). A maximum reading of 10-20 mrem/hr is normal, and indicates the source is present. However, if the maximum reading is less than 1 mrem/hr or if a survey meter is not available, perform a visual inspection of the source rod tip as follows to confirm its integrity:

1. Extend the source rod just far enough to see the source rod tip. The tip should appear flat to slightly rounded and smooth.
2. Stay at least 3 ft (1 m) away from the tip of the unshielded source rod and complete the inspection as quickly as possible to minimize exposure (the dose rate at 3 ft from the unshielded source is about 2.7 mrem/hr).

If the visual inspection indicates the source rod tip is broken off (source is missing):

1. Immediately contact your Radiation Safety Officer (RSO).
2. Initiate a search for the source starting at the location where the gauge was last used.
3. Report lost or missing radioactive sources to your state or federal radiation control agency in accordance with applicable regulatory requirements.
4. Contact the Troxler Radiation Safety Department for further advice.

GAUGE READINGS APPEAR ERRATIC

- ✓ If taking readings in the backscatter position, ensure the source rod is properly locked in the notch and not resting on the test material.
- ✓ Check the inside of the gauge for moisture. To dry the gauge interior, remove the keypad. If necessary, use a hair dryer (on low heat) to circulate warm air for one to three hours.
- ✓ Remove any foreign objects from inside the gauge.
- ✓ Ensure the hardware mounting screws are tight and in place.
- ✓ Check count time – A 4-minute count will give the best precision with a repeatability of ± 1 pcf.
- ✓ Erratic density readings may be caused by a dirty sliding block. Clean the sliding block.
- ✓ Perform a statistical stability (stat) test. If test passes, proceed with job. If test fails, repeat two more times. If test fails two out of three times, contact Troxler Service.

GAUGE MEASUREMENTS ARE UNSTABLE; TUBES TEST OKAY

- ✓ Possible High Voltage Module or baseboard malfunction.

GAUGE TURNS OFF AFTER IT IS TURNED ON, OR WILL NOT TURN ON

- ✓ The gauge automatically turns off after five hours if no keys are pressed. Try to turn the gauge on again.
- ✓ Gauge may be wet. If the gauge is wet, dry the gauge interior with hair dryer (on low heat) for three hours. Do not turn gauge on until moisture is removed from the gauge interior or serious damage of electronic components may result!
- ✓ Batteries are below 6.0 V dc. Recharge or replace batteries.

NON-FUNCTIONING DEPTH INDICATOR

- ✓ Possible CPU Board malfunction or defective indicating strip. Use manual override or recalibrate depth indicator.

GAUGE INDICATES SHORT BATTERY LIFE AFTER RECHARGING

- ✓ NiCad batteries may be charged up to 100 full charge/discharge cycles. Batteries may be reaching end of life cycle-replace.
- ✓ Charger/adapter may not be supplying the full voltage to the batteries; check the ac outlet and the dc output (12 V dc).
- ✓ Check that you are using the correct charger.
- ✓ The ac charger may be defective. To check, use the dc charger to charge the batteries.
- ✓ Remove any loose screws or foreign objects from the gauge interior that may cause an electrical short to ground.
- ✓ CPU or baseboard malfunction.

BATTERY LIFE HOURS ARE INCORRECT

- ✓ Charge the gauge overnight (16 hours).
- ✓ Check battery voltage. If battery voltage is equal or greater than 7.0 volts, manually enter the correct hour value. With a new gauge after a full 16-hour charge, enter a battery life of 200. With age the battery life will decrease, so enter 200 hours and monitor the gauge until <Batteries low!> is displayed. After the next recharge, enter the new battery life (200 - battery low life). The operator may leave the gauge in *voltage* mode for future reference. If battery voltage is less than 7.0 volts, change the mode to the *elapsed time* since last charge. Monitor gauge until <Batteries low!> is displayed. If the time is too low (less than 16 hours), replace the batteries.

RS-232 PORT DOES NOT FUNCTION CORRECTLY

- ✓ Check for proper baud rate.
- ✓ Check printer.
- ✓ Check cable and connectors.
- ✓ Check CPU jumper configuration and cable pins 2 and 3. Also, possible CPU Board malfunction.

COUNTS ARE SATISFACTORY, BUT RESULTS ARE IN ERROR

- ✓ Ensure the measurement depth corresponds to the actual source rod depth.
- ✓ Check the calibration constants.
- ✓ Check to see if an offset (density, moisture, trench, or special) is enabled.
- ✓ Ensure the standard counts are correct.

GARBAGE OR “+++++” IS DISPLAYED

- ✓ Check the standard counts in memory. If the standard counts are suspect, perform new standard counts. If counts equal zero for both systems, replace high voltage board (contact the Service Department).
- ✓ Check gauge for water damage. If the gauge is wet, dry the gauge interior with hair dryer (on low heat) for 3 hours.
- ✓ Check the calibration constants. They should match the constants on your calibration data sheet if your calibration sheet is in metric units. Refer to the *Calibration Constants* section on page 7–6 to determine if your calibration sheet is metric and, if not, for instructions on converting B and F values from metric to English units.
- ✓ If necessary, perform a statistical stability test, record the results and call Customer Service.

POSSIBLE MALFUNCTION INDICATORS

CPU Board

Display malfunctions

No keypad response

RAM test fails

Batteries do not recharge

Battery Low indicator does not function correctly

Keyboard test fails with front panel disconnected from CPU Board

Gauge does not access plug-in option module or does not function properly with module plugged in (if option module is functioning correctly)

Display test fails

Gauge does not turn Off

Fuse blows repeatedly

Beeper stops (or is erratic)

Gauge does not turn On when charger is connected.

Auto depth indicator, battery low, and gauge automatic shutdown do not function properly.

Preamp Board

No moisture or density counts

Batteries do not recharge

Gauge fails tube test

Fuse blows repeatedly

Gauge fails stability or drift test

High Voltage Module

No moisture or density counts

Moisture or density counts are unstable

Batteries discharge prematurely

Fuse blows repeatedly

Gauge fails stability or drift test

ERROR MESSAGES

When first turned on, the 3440 gauge enters a *Self-Test* phase to check the internal systems for proper operation. If a fault is encountered during this internal systems check, an error message is displayed.

The following error messages may be encountered in normal day-to-day operation. These errors can usually be corrected if the operator takes proper action.

<u>Error Message</u>	<u>Corrective Action</u>
Error #6 – Data Previously stored.	Take another reading before storing.
Error #7 – No serial device connected!	Check cables, connectors & printer.
Error #8 – Illegal baud rate!	Re-enter another baud rate.
(No Error #) Time to reach precision too high!	Re-enter lower precision value.
(No Error #) Invalid Depth!	Change rod depth.

The following errors are not operator serviceable. Contact your Troxler Service Department for more information.

- Error #1 - Data NVRAM test error!**
- Error #2 - Key Pad test error!**
- Error #3 - GM Tube test error!**
- Error #4 - Helium Tube test error!**
- Error #5 - Display test error!**

REPLACEMENT PARTS

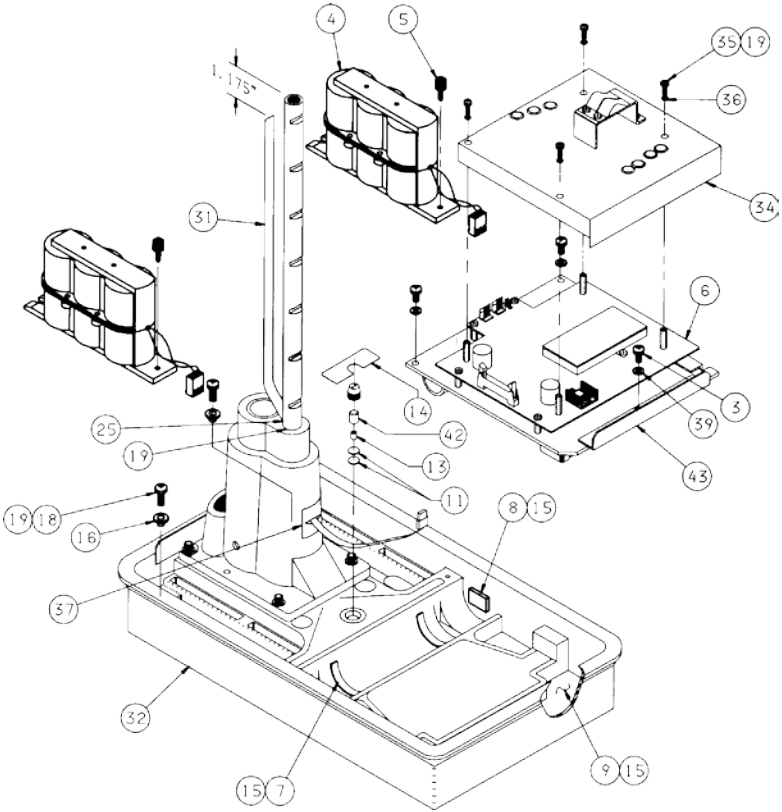

Figure F-3. 3440 Gauge Assembly (Sheet 1 of 2)

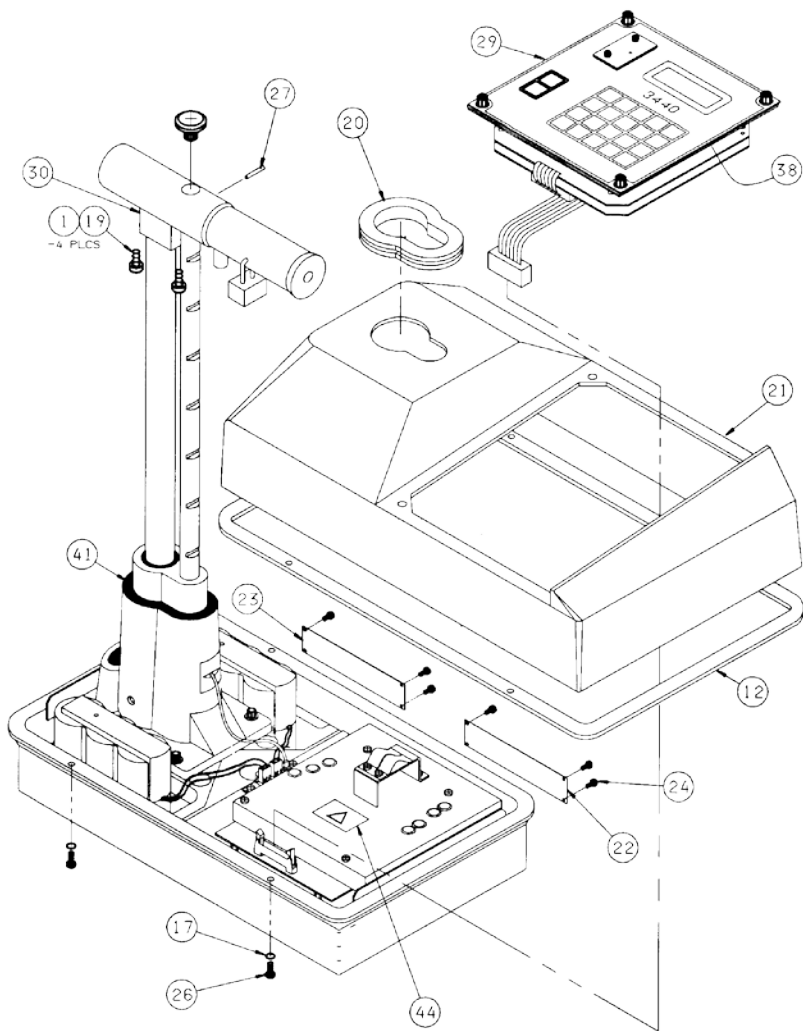

Figure F-3. 3440 Gauge Assembly (Sheet 2 of 2)

Table F-1. 3440 Gauge Assembly Parts

Match the reference number (Ref #) with the correct part in Figure F-3 on the two previous pages.

<u>Ref #</u>	<u>Part Number</u>	<u>Description</u>	<u>Qty</u>
1	000212.4201	Screw, 4-40 x 3/4 S.H.C. SS	4
3	000408.1431	Screw, #8 x 1/2 PH Phil SS Type B	3
4	104149	3440 Battery Assembly	2
5	100528.2000	Screw, Captive	2
6	108330	3440/3430 Preamp Assembly	1
7	102070	3400 Heat Shield	2
8	102071	End Protector	2
9	102074	3400 Filter	1
11	107413	Lead Disk	1
12	106368	Gasket, Top Cover	1
14	107415	Radiation Label	1
16	000025.1026	Bushing, #10 x 0.250D x 0.187L Nylon	2
17	000001.0601	Washer, #6 Internal Lock SS	4
18	000610.1430	Screw, 10 x 5/8 PH Phil Type E	2
20	100989	Gasket - Molded for Base Post	1
21	106068	Topshell, 3440/3440	1
22	108329	3440 Nameplate	1
23	104122	Radiation Label	1
24	000900.0621	Screw, #4 (.114 Dia.) x 3/16" Drive	8
26	000310.4891	Screw, 6-32 x 5/8 SHCS w/ Insert	4
27	101603.1010	Roll Pin, 3/32 Dia. x 5/8 L	1
29	108335	3440 Front Panel Assembly	1
30	104130	Plunger Block	1
31	104106.1200	Depth Indicating Strip, 12-inch	1
	104106.0800	Depth Indicating Strip, 8-inch	1

Table F-1. 3440 Gauge Assembly Parts (Continued)

<u>Ref #</u>	<u>Part Number</u>	<u>Description</u>	<u>Qty</u>
Match 3440 Base Mechanics to Part Numbers Shown			
32	105341.0801	3440 Base Mechanical Assembly 8-1 (For 104125.0801)	1
	105341.0802	3440 Base Mechanical Assembly 8-2 (For 104125.0802)	1
	105341.1201	3440 Base Mechanical Assembly 12-1 (For 104125.1201)	1
	105341.1202	3440 Base Mechanical Assembly 12-2 (For 104125.1202)	1
	105341.1235	3440 Base Mechanical Assembly 12-3-5 (For 104125.1235)	1
34	108334	Assembly, Preamp Cover Box	1
35	000206.1400	Screw, 4-40 x 3/8 PHMS Phil	4
36	000001.0401	Washer, #4 Internal Lock SS	4
37	106340	Gasket, Depth Strip Hole	1
38	102662	Scaler Label (3401-3411)	1
39	000001.0801	Washer, #8 Internal Lock SS	3
40	103484	Reference Standard Assembly (3400)	1
41	106367	Gasket, Tower Flat	1
42	107414	Source Spacer	1
43	108346	Gasket Bracket, Front	1
44	108347	Label, Caution	1

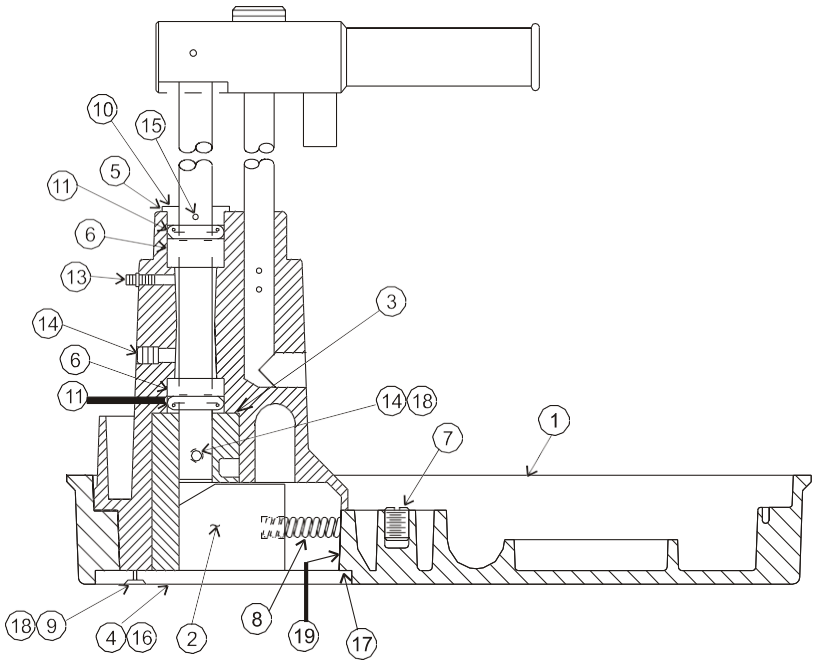

Figure F-4. 3440 Base Mechanical Assembly

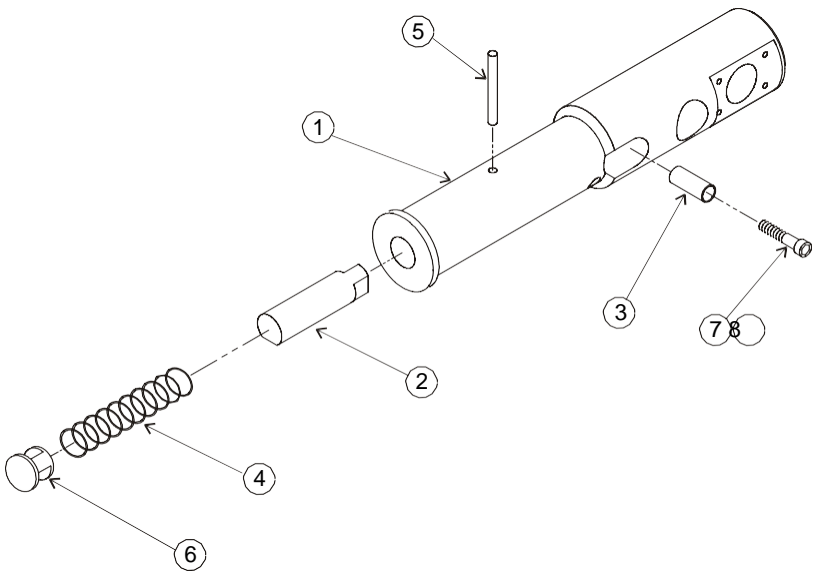

Figure F-5. 3440 Source Rod Handle Assembly

Table F-2. 3440 Base Mechanical Assembly Parts

Match the reference number (Ref #) with the correct part in Figure F-4 on the opposite page.

<u>Ref #</u>	<u>Part Number</u>	<u>Description</u>	<u>Qty</u>
1	105256	3400 Base Machining	1
2	100996	3400 Sliding Block	1
3	102351	3400 Round Bioshield	1
4	105264	3400 Bottom Plate Assembly	1
5	102069.1000	2400/3400 Wiper Cap	1
6	104594	Source Rod Bearing	2
7	107412	Source Cap	1
8	102399	3400 Shield Spring LC-055H-6	1
9	000608.1101	Screw, 10-32 x 1/2 FHMS Phil SS	4
10	012752	Seal, Wiper (V.S. S-35-14)	1
11	012759	Seal, Oil ID 5/8" #6204	2
13	013200	Fitting, 3/16 Grease w/ Serrated Shank	1
14	001006.4090	Screw, 5/16-18 x 3/8 Set Knurl	3
15	101603.0510	3/32 Dia. x 5/16 L. Roll Pin	2
16	012789	Magnalube-G Lubricant 14.5 oz	.01
17	105239	Baseplate Gasket	1
18	018127.0001	Loctite, 242	.001
19	105309	Spring Guide	1

Table F-3. 3440 Source Rod Handle Assembly Parts

Match the reference number (Ref #) with the correct part in Figure F-5 on the opposite page.

<u>Ref #</u>	<u>Part Number</u>	<u>Description</u>	<u>Qty</u>
1	104556	Gauge Handle 3440	1
2	104553	3400 Plunger	1
3	105108	Trigger	1
4	012200	Spring, Lee #LC-0242G-7	1
5	101604.1610	Roll Pin, 1/8 Dia. x 1"	1
6	012779.3000	Plug, Heyco Cap. #2643, Black	1
7	000824.4800	Screw, 1/4 - 20 x 1-1/2 Soc. HD Cap	1
8	018127.0001	Loctite 242	.005

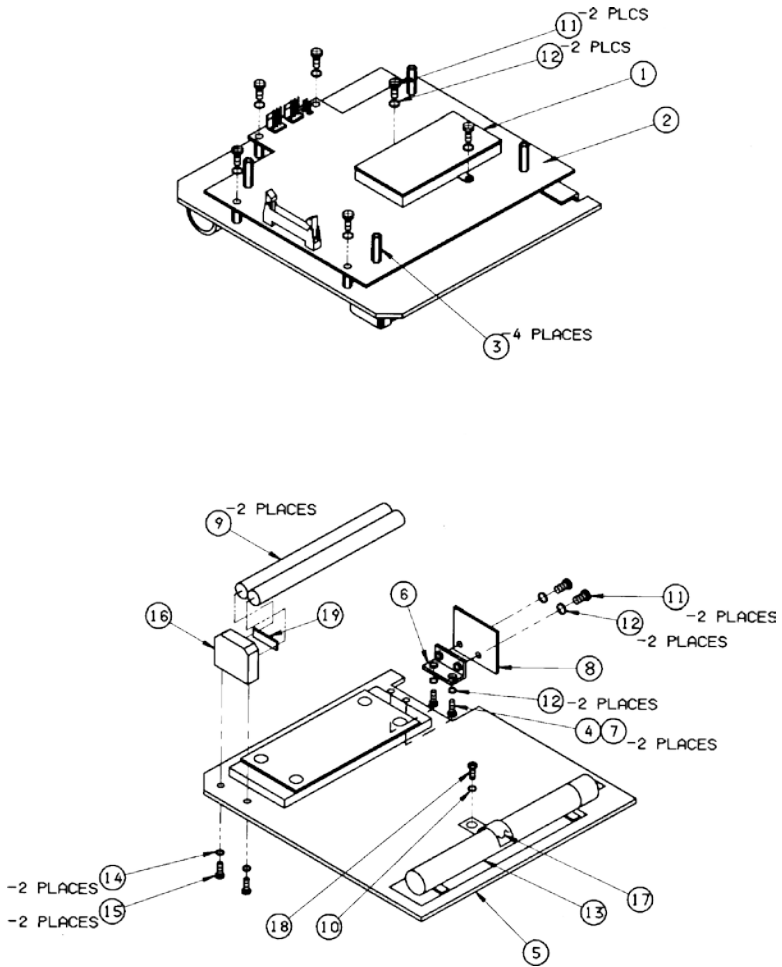

Figure F-6. 3440 Preamplifier Assembly

Table F-4. 3440 Preamplifier Assembly Parts

Match the reference number (Ref #) with the correct part in Figure F-6 on the opposite page.

<u>Ref #</u>	<u>Part Number</u>	<u>Description</u>	<u>Qty</u>
1	107903	Assembly, Preamp Baseboard	1
2	107164	Assembly, High Voltage Board	1
3	000923.2442	Spacer, 4-40 x .75 M/F	4
4	018127.0001	Loctite 242	.001
5	108328	Preamp Mechanical Assembly	1
6	104136	Interface PC Board Bracket	1
7	000206.1400	Screw, 4-40 x 3/8 PHMS Phil	2
8	104098	G-M Tube Interface PCB Assembly	1
9	100156	G-M Tube	2
10	000001.1001	Washer, #10 Internal Lock SS	1
11	000204.1400	Screw, 4-40 x 1/4 PHMS Phil SS	8
12	000001.0401	Washer, #4 Internal Lock SS	10
13	104094.0001	900 V dc Moisture Tube Assembly	1
14	000001.0601	Washer, #6 Internal Lock SS	2
15	000306.1401	Screw, 6-32 x 3/8 PHMS Phil SS	2
16	107854	G-M Tube Holder	1
17	103540	Modified Tube Clamp	1
18	000604.1400	Screw, 10-32 x 1/4 PHMS Phil SZ	1
19	102119	7M Tube Pad	1

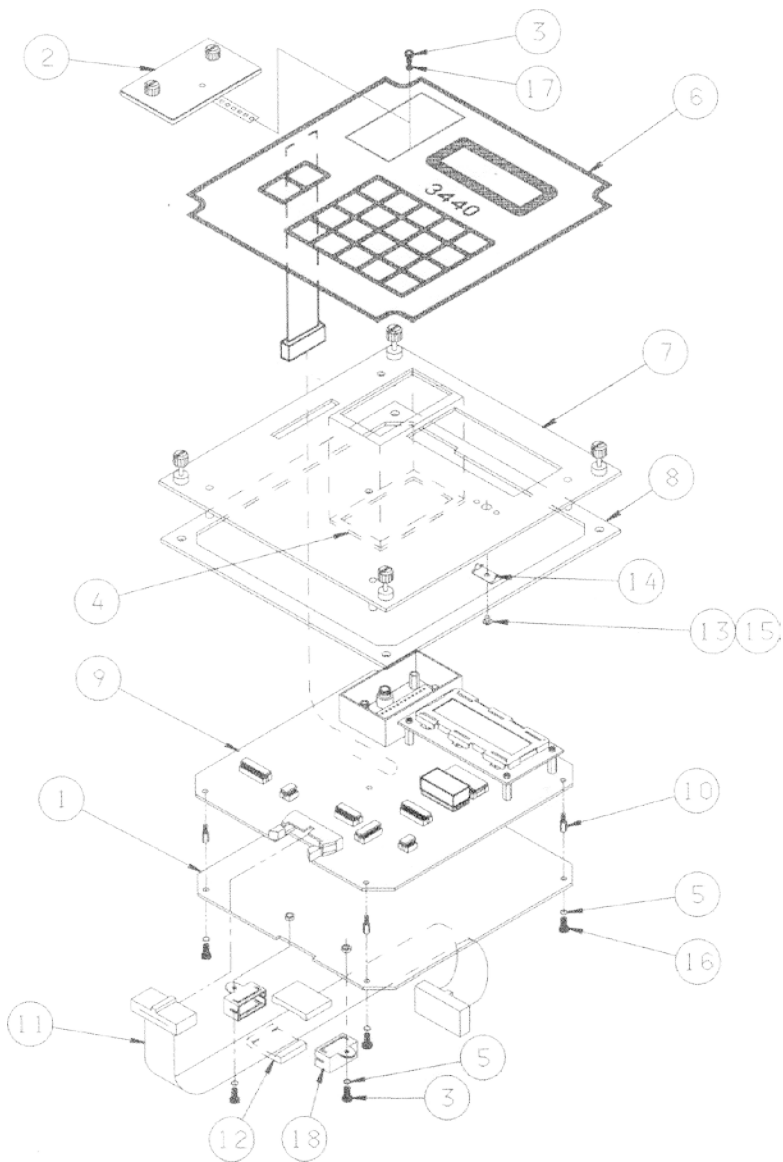

Figure F-7. 3440 Front Panel Assembly

Table F–5. 3440 Front Panel Assembly Parts

Match the reference number (Ref #) with the correct part in Figure F–7 on the opposite page.

<u>Ref #</u>	<u>Part Number</u>	<u>Description</u>	<u>Qty</u>
1	108331	Ground Plate, CPU PC Board	1
2	104184.1000	Cover Plate Assembly	1
3	000204.1400	Screw, 4-40 × 1/4 PHMS Phil SS	3
4	107947	EMI Gasket 3440	1
5	000001.0401	Washer, #4 Internal Lock SS	7
6	104115	3440 Overlay	1
7	104134	3440 Front Panel	1
8	106369	Front Panel Gasket	1
9	107893	3440 CPU PCB Assembly	1
10	000923.0842	Spacer, 4-40 × 1/4 Lg. M/F Hex	5
11	102888	Cable, 3400-B Series	1
12	108314.0001	Ferrite Split Half	2
13	000202.1400	Screw, 4-40 × 1/8 PHMS Phil SZP	1
14	106856	Clamp, Grounding	1
15	018128.0001	Loctite 290 Wick & Seal	.001
16	000203.1401	Screw, 4-40 x 3/16 PHMS Phil SS	5
17	000011.0401	Washer, #4 Flat SS 5/16 OD	1
18	108314.1001	End Cap for Ferrite Split Half	2

NOTE

The following parts are not shown in the previous figures.

ACCESSORIES

<u>Part Number</u>	<u>Description</u>
110403	AC Adapter, 12 V CE
104156	DC Charger
100421	Drill Rod
102111	Scraper Plate (Drill Rod Guide)
103484	Standard Assy (3400) (Reference Standard Block)
103680.1000	Extraction Tool
106875.0002	Concrete Adapter 3400 2" w/Acc.
106875.0004	Concrete Adapter 3400 4" w/Acc.
106875.0008	Concrete Adapter 3400 8" w/Acc.
106875.0010	Concrete Adapter 3400 10" w/Acc.
106875.0012	Concrete Adapter 3400 12" w/Acc.
103623.3440	3440 Shipping Case/Carton Assy
104279	3440 Instruction Manual
104337	3440 Reference Card

OPTIONAL ACCESSORIES

<u>Part Number</u>	<u>Description</u>
104148	Accessory Battery Case Assembly
102868	Leak Test Kit w/4 packets
102876.0005	Leak Test Packet (4 units)
102873	1 oz. solution detergent
109661	Survey Meter
021140	Radiation Sign Kit
104122	Radiation Label
104661.1000	Print Pkg. 3440
104324.1000	Cable, (Weigh-Tronix®) Printer-to-Gauge (M/M)
104340	3440 Printer
104341	3440 Printer Battery Pack
104334.1000	Cable, PC-to-Gauge (FEM/MAL)
104719	Interfacing PGM Disk/Manual

MAINTENANCE SUPPLIES

<u>Part Number</u>	<u>Description</u>
012786	Lubricant Magnalube-G Paste 1 lb. Can
012789	Lubricant Magnalube-G 14.5 oz.
100761	Source Rod Pig

RETURNING A GAUGE FOR SERVICE

All shipments within the U.S. to the factory must comply with 49 CFR (see Appendix E). Items returned for service must be accompanied by a Returned Good Authorization (RGA) number, and a description of the instrument and its problem. This information is used by Troxler shipping and service personnel to expedite the repair work.

To obtain an RGA number, please call or fax the factory with your request. Please have the following information available when calling or faxing Troxler for an RGA number:

- ◆ System model and serial number.
- ◆ Part number/serial number (if applicable).
- ◆ Is system still under warranty?
- ◆ Problem or difficulty you are having with the instrument.
- ◆ Shipment method to Troxler and for return shipment.
- ◆ Shipping and billing address (not P.O. Box) - street address and zip.
- ◆ Phone number/contact (for questions from Troxler).
- ◆ Will estimate be required prior to performing any work on the system?
- ◆ Payment method: credit card, account number, or purchase order number. All government agencies (city, county, state, and federal) must send purchase order numbers.

NOTE

To prevent order duplication, if an order has been placed by telephone, please write “Confirming Order” on any follow-up written requests.

NOTE

Returning a 3440 gauge requires special handling and shipping procedures. Follow the instructions in Appendix E. Please contact a Troxler Sales Support or Service Representative with any questions.

NOTES

APPENDIX G

3440 SPECIFICATIONS

This appendix contains measurement and gauge specifications for the 3440 gauge.

CONTENTS

Measurement Specifications.....	G-2
U.S. Customary Units	G-2
SI Units	G-2
Calibration Specifications	G-3
Radiological Specifications	G-3
Memory Specifications	G-3
Electrical Specifications	G-4
Mechanical Specifications.....	G-5

MEASUREMENT SPECIFICATIONS

U.S. CUSTOMARY UNITS

<u>Direct Transmission, 6 inches</u>	<u>15 sec.</u>	<u>1 min.</u>	<u>4 min.</u>
Precision at 125 pcf	±0.42 pcf	±0.21 pcf	±0.11 pcf
Composition error at 125 pcf	±1.25 pcf	±1.25 pcf	±1.25 pcf
Surface error (0.05 in., 100% void)	-1.06 pcf	-1.06 pcf	-1.06 pcf

Backscatter Density, (98%) 4 inches

Precision at 125 pcf	±1.00 pcf	±0.50 pcf	±0.25 pcf
Composition error at 125 pcf	±2.50 pcf	±2.50 pcf	±2.50 pcf
Surface error (0.05 in., 100% void)	-4.68 pcf	-4.68 pcf	-4.68 pcf

Moisture

Precision at 15 pcf	±0.64 pcf	±0.32 pcf	±0.16 pcf
Surface error (0.05 in., 100% void)	-1.12 pcf	-1.12 pcf	-1.12 pcf

Depth of measurement at 15 pcf – 8.5 inches

SI UNITS

<u>Direct Transmission, (150 mm)</u>	<u>15 sec.</u>	<u>1 min.</u>	<u>4 min.</u>
Precision at 2000 kg/m ³	±6.8 kg/m ³	±3.4 kg/m ³	±1.7 kg/m ³
Composition error at 2000 kg/m ³	±20.0 kg/m ³	±20.0 kg/m ³	±20.0 kg/m ³
Surface error (1.25 mm, 100% void)	-17.0 kg/m ³	-17.0 kg/m ³	-17.0 kg/m ³

Backscatter Density, (98%) 100mm

Precision at 2000 kg/m ³	±16.0 kg/m ³	±8.0 kg/m ³	±4.0 kg/m ³
Composition error at 2000 kg/m ³	±40.0 kg/m ³	±40.0 kg/m ³	±40.0 kg/m ³
Surface error (1.25 mm, 100% void)	-75.0 kg/m ³	-75.0 kg/m ³	-75.0 kg/m ³

Moisture

Precision at 240 kg/m ³	±10.0 kg/m ³	±5.0 kg/m ³	±2.5 kg/m ³
Surface error (1.25 mm, 100% void)	-18.0 kg/m ³	-18.0 kg/m ³	-18.0 kg/m ³

Depth of measurement at 240 kg/m³ – 215 mm

CALIBRATION SPECIFICATIONS

Uncertainty of density standards: $\pm 0.2\%$

Uncertainty of moisture standards: $\pm 2.0\%$

Calibration standards range

Density: 109 – 165 pcf (1750 – 2640 kg/m³)

Moisture: 0 – 40 pcf (0 – 640 kg/m³)

Gauge operational range

Density: 70 – 170 pcf (1100 – 2700 kg/m³)

Moisture: 0 – 40 pcf (0 – 640 kg/m³)

Method: Computer reduction of count rate data based on U.S. National Bureau of Standards Electron Cross Sections, Neutron Cross Sections, and Absorption Coefficients. Data is reduced to the form $D = (1/B) \ln(A/(CR + C))$ for density and $M = (CR - E)/F$ for moisture where A, B, C, E, and F are constants and CR is count ratio. The algorithm corrects for hydrogen photon-scattering coefficients and provides means for offsetting non-water hydrogen. Direct calibration entry by keypad.

RADIOLOGICAL SPECIFICATIONS

Gamma source	0.3 \pm 10% GBq (8 \pm 10% mCi) Cs-137
Neutron source	1.48 GBq 10% (40 \pm 10% mCi) Am-241:Be
Source housing	Stainless steel, encapsulation
Shielding	Tungsten, lead, and cadmium
Surface dose rates	See <i>3440 Radiation Profile</i> on page C-4
Source rod material	Stainless steel
Shipping case	DOT 7A, Type A, Yellow II label, TI = 0.6
Certificates of Competent Authority	CS-137 – USA/0614/S or USA/0356/S Am-241:Be – USA/0632/s or CZ/1009/S
Registry of Radioactive Sealed Sources and Devices	NC-646-D-130-S

MEMORY SPECIFICATIONS

RAM	64K Resident, Non-volatile Stores over 450 complete station records 192K External
ROM	256K or 512K Resident, 512K External

ELECTRICAL SPECIFICATIONS

Time accuracy and stability	$\pm 0.005\% \pm 0.0002\%/^{\circ}\text{C}$
Power supply stability	$\pm 0.01\% ^{\circ}\text{C}$
Stored power	30 watt-hours
Battery recharge time	16 hours, automatic cutoff
Charge source	12-14 V dc, 500 mA minimum
Liquid crystal display (LCD) readout	4 x 16 alphanumeric
Power consumption (watts) average	0.16
Power consumption after automatic battery cutoff (watts)	0.00
Serial data format	8 Data Bits, 2 Stop Bits, No
Parity	

Gauge to PC-compatible Computer Cable (Null Modem Cable):

Gauge	Computer
<u>(Male)</u>	<u>(Female)</u>
Gnd (pin 1).....	Gnd (pin 1)
Tx (pin 2).....	Rx (pin 3)
Rx (pin 3).....	Tx (pin 2)
DSR (pin 6).....	DTR (pin 20)
DTR (pin 20).....	DSR (pin 6)
Gnd (pin 7).....	Gnd (pin 7)

Gauge to WEIGH-TRONIX® Printer Cable:

Gauge	Printer
<u>(Male)</u>	<u>(Male)</u>
Gnd (pin 1).....	Chassis Gnd (pin 1)
Tx (pin 2).....	RD (pin 2)
DSR (pin 6).....	CTS (pin 5)
Gnd (pin 7).....	Gnd (pin 7)

Gauge returns to *Ready* (power saving mode) after 2 minutes of operator inactivity, except in *STD*, *Stat Test*, *Drift Test*, and *Nomograph* (30 minutes). After 5 hours of complete inactivity, gauge performs a total power shutdown.

Battery packs are fully protected against overcharge and over-discharge; charge life is updated every 1.9 seconds and is indicated on the **READY** display.

Emergency Use – Capable of operation with six “D” size alkaline batteries. Not all “D” size alkaline batteries will fit.

MECHANICAL SPECIFICATIONS

Vibration test	0.1 in. (2.54 mm) at 12.5 Hz
Drop test	300 mm on 25 mm diameter steel ball
Operating temperature	
– Ambient:	14 to 158°F (–10 to 70°C)
– Surface:	350°F (175°C)
Storage temperature	–70 to 185°F (–57 to 85°C)
Gauge size (excluding handles)	14.8 x 9.1 x 7.2 in. (376 x 231 x 183 mm)
Gauge height (including handles)	12-in. rod – 23.25 in. (591 mm) or 8-in. rod – 19.25 in. (489 mm)
Shipping case dimensions	29.35 x 13.88 x 16.85 in. (74.55 x 35.26 x 42.80 cm)
Weight	29 lb (13.1 kg)
Shipping weight	90 lb (40.8 kg) in shipping case

NOTES

APPENDIX H

LOG FORMS & COMPACTION TEST DATA

CONTENTS

Standard Count LogH-2

Nuclear Compaction Test DataH-4

STANDARD COUNT LOG

Serial Number _____

Date	Moisture - MS	Density - DS	Date	Moisture - MS	Density - DS

H. LOG FORMS & TEST DATA

NUCLEAR COMPACTION TEST DATA

PROJECT _____
JOB NUMBER _____
DATE _____
TAKEN BY _____

TEST NUMBER	1	2	3	4	5	6	7	8	9	10
STATION										
OFFSET										
ELEVATION										
MODE AND DEPTH										
DENSITY COUNT										
WET DENSITY										
MOISTURE COUNT										
MOISTURE										
DRY DENSITY										
% MOISTURE										
STANDARD DENSITY										
OPTIMUM MOISTURE										
% COMPACTION										
MOISTURE CORRECTION										

TEST NUMBER	11	12	13	14	15	16	17	18	19	20
STATION										
OFFSET										
ELEVATION										
MODE AND DEPTH										
DENSITY COUNT										
WET DENSITY										
MOISTURE COUNT										
MOISTURE										
DRY DENSITY										
% MOISTURE										
STANDARD DENSITY										
OPTIMUM MOISTURE										
% COMPACTION										
MOISTURE CORRECTION										

		REMARKS	
DENSITY	MOISTURE		

APPENDIX I

UNIT CONVERSION

The 3440 gauge can display measurement results in either SI (metric) units or English units. Also, HM-181 of 49 CFR changes the standard units of radioactivity in the United States from the English unit of curies (Ci) to the SI unit of becquerel (Bq). This requires the shipper to convert the activity on the Bill of Lading from curies to becquerels. Until everyone is accustomed to the SI units, it is permitted to follow the SI units with the English units in parentheses to clarify the description, such as *1.49 GBq (40 mCi)*.

To help our operators convert from English units to SI units, the table in this appendix provides SI conversion factors for common English units relevant to the 3440 gauge.

CONTENTS

Measurement Units	2
Radiological Units	2

MEASUREMENT UNITS

$$1 \text{ in.} = 25.4 \text{ mm}$$

$$1 \text{ in.} = 2.54 \text{ cm}$$

$$1 \text{ ft} = 30.48 \text{ cm}$$

$$1 \text{ ft} = 0.3 \text{ m}$$

$$1 \text{ pcf} = 16.02 \text{ kg/m}^3$$

$$1 \text{ pcf} = 1.6 \times 10^{-2} \text{ g/cm}^3$$

RADIOLOGICAL UNITS

$$1 \text{ rem} = 0.01 \text{ Sv}$$

$$1 \text{ Ci} = 37 \text{ GBq}$$

$$1 \text{ mCi} = 37 \text{ MBq}$$

$$1 \mu\text{Ci} = 37 \text{ kBq}$$

The following table is provided to assist you in converting from millicuries (mCi) to gigabequerels (GBq):

<u>mCi</u>	to	<u>GBq</u>
8.0.....		0.30
40.....		1.48

APPENDIX J

PRINTING (UPLOADING) PROJECT DATA

Current versions of Microsoft→ Windows→ include a *HyperTerminal* communications program that can be used to transfer project data from the Model 3440 Surface Moisture-Density Gauge to a computer. This appendix provides instructions on using the *HyperTerminal* program to print (upload) data from the gauge.

CONTENTS

Windows Hyperterminal	J-2
HyperTerminal Setup	J-2
Equipment Connection	J-3
Printing (Uploading) Project Data	J-3
Viewing Project Data	J-4

WINDOWS HYPERTERMINAL

To print (upload) data from the gauge to a computer equipped with the Windows operating system, use the *HyperTerminal* program as described in the following sections.

HYPERTERMINAL SETUP

To configure the Windows *HyperTerminal* program and set up a dedicated icon to transfer data from the gauge, perform the following steps:

1. Click on the **Start** button, then select the **Programs** menu and the **Accessories** folder.
 - ▶ In Windows 95, select the **HyperTerminal** icon.
 - ▶ In Windows 98 and later versions, select the **Communications** subfolder, then select the **HyperTerminal** icon.
2. From the **HyperTerminal** window, double-click on the **Hypertrm** icon. The **Connection Description** window is displayed. This window is used to set up a new connection.
3. In the **Name** box, enter a name (for example, *Troxler Data*) for the new connection. Select an icon to use for the connection, then click **OK**. The **Connect To** window is displayed.
4. In the **Connect To** window, **do not** enter a telephone number. Instead, select **Direct to Com1**, **Direct to Com2**, **Direct to Com3**, or **Direct to Com4**, depending upon the computer. The **COM# Properties** window is displayed, where # is the number of the selected COM port.
5. Configure the **Port Settings** as follows:

Bits per second	Select same value as gauge baud rate (see page 6–25)
Data bits	8
Parity	None
Stop bits	1
Flow control	Hardware
6. Click **OK**. The **Troxler Data – HyperTerminal** window is displayed, where *Troxler Data* is the icon name entered in step 3.
7. From the toolbar, click on **File** and select **Save** from the dropdown menu.
8. Close the **Troxler Data – HyperTerminal** window by selecting **Exit** from the **File** menu.

EQUIPMENT CONNECTION

Connect the gauge to the computer using the appropriate serial cable (see the list of *Optional Accessories* on page C–26). Connect the gauge’s serial port (see Figure 5–2 on page 5–18) to the computer COM port selected in step 4 of the *HyperTerminal Setup* section on the previous page.

PRINTING (UPLOADING) PROJECT DATA

To print (upload) project data from the gauge to the computer:

1. On the computer, click on the **Start** button, then select the **Programs** menu and the **Accessories** folder.
 - ▶ In Windows 95, select the **HyperTerminal** icon.
 - ▶ In Windows 98 and later versions, select the **Communications** subfolder, then select the **HyperTerminal** icon.
2. From the **HyperTerminal** window, double-click on the **Troxler Data – HyperTerminal** icon (where *Troxler Data* is the icon name entered in the *HyperTerminal Setup* section on the previous page). The **Troxler Data – HyperTerminal** window is displayed.
3. From the toolbar, click on **Transfer**, then select **Capture Text** from the dropdown menu. The **Capture Text** window is displayed, showing the default folder and filename to be used to store the data. Troxler recommends using the default settings when first using the program.
4. On the 3440 gauge, select the project data to be printed (downloaded) to the computer, and follow the instructions in Chapter 5 to print the data to the computer. The project data will be displayed in the **Troxler Data – HyperTerminal** window as it is downloaded.
5. When the data transmission is complete, select **Transfer** from the toolbar. Then select **Capture Text** and **Stop** from the dropdown submenu.

VIEWING PROJECT DATA

After project data has been printed (uploaded) to the computer, it can be viewed using either a word processing program (such as Microsoft Word→) or a spreadsheet program (such as Microsoft Excel→). To view the data, open the desired program, then open the file in which the project data was stored.

NOTE

The user can also use the spreadsheet program to design a spreadsheet to manipulate and manage the data.

INDEX

%
% Marshall2-7

A

Absorbers, neutron 5-5
Access code , 7-1
Accessories 1-4, F-26
Accident notification E-3
Addition (calculator function) 5-24
Agreement state 1-3
ALARA concept C-3
Alkaline batteries F-2
Alpha particles C-2
Asphalt
 Measurement 4-3
 Mode 2-6, 4-3
 Surface preparation 3-4
ASTM standards 1-2
Atom
 Nucleus B-2
 Structure B-2
Automatic shutdown 2-2, G-4
Auto-Station function 4-4, 6-11

B

Backscatter 4-3, A-2
Base course preparation 3-2
Baseboard assembly F-9
Basic parameter setup 2-4
Battery
 Alkaline F-2
 Charger 1-4
 Monitor function 6-27
 Recharging F-2
Baud Rate function 6-25
Becquerel B-3
Beta particles C-2
Block, reference standard 1-4, 2-13
Bottom density 6-15
Burn-In function 7-10

C

Calculator	
Function	5-24
Keys	1-6
Calibration	
Constants function.....	7-6
Date function.....	7-5
Depth.....	5-23
Special.....	6-12
Specifications	G-3
Standard function	7-11
Canadian Nuclear Safety Commission (CNSC).....	E-4
Canadian shipping requirements	E-4
Case, transport.....	1-4
Cautions and warnings.....	iv
Charger, battery.....	1-4
Clock/calendar	2-11
Communication Protocol function	6-26
Control panel.....	1-6
Core density	6-19
Count	
Standard	2-13
Time.....	2-5
Counts function.....	5-21
Curie.....	B-3
Customer Name function	7-3

D

Daily inspection	2-2
Declaration of Conformity	v
Density	
Bottom.....	6-15
Core.....	6-19
Measurement.....	A-2
Measurements	4-1
Offset	5-4
Department of Transportation (DOT)	E-1
Depth	
Calibration.....	5-23
Function	5-22
Mode	5-22
Of Measurement.....	A-5
Strip.....	5-22
Direct transmission	A-2
Disposal	D-4

Distance, limiting radiation exposure.....	C-3
Division (calculator function)	5-25
Dosimeter	C-4
Downloading data	5-18
Drift test	6-7
Drill rod.....	1-4, 3-2
Extraction tool.....	1-4, 3-2
Guide.....	1-4

E

Electrical specifications.....	G-4
Electron	B-2
Electronic maintenance	F-9
Emergency procedures	C-6
Encapsulation, source.....	C-6
Erase	
Function	5-21
Project	2-10
Standard Counts function	7-9
Erratic readings	6-3
Error messages	F-15
Extended functions.....	7-1
Extraction tool.....	1-4, 3-2

F

Federal regulations	1-3
---------------------------	-----

G

Gamma radiation.....	C-2, A-2
Gaskets	F-7
Gauge	
Operation.....	5-1
Setup	2-4

H

Half-life.....	B-3
Hazmat training	E-3
He-3 detectors	A-5
HyperTerminal program.....	J-2

I

Incidents.....	D-3
Index rod.....	2-13
Inspection	
Daily.....	2-2
Source rod.....	F-4
International Air Transport Association (IATA).....	E-1
International Atomic Energy Agency (IAEA).....	E-1

K

Keypad.....	1-6
Data function.....	6-10

L

Leak test.....	D-3
Licensing requirements.....	D-1

M

Maintenance.....	F-1
Electronic.....	F-9
Gaskets.....	F-7
Mechanical.....	F-4
Scraper ring.....	F-5
Source rod bearing.....	F-6
Supplies.....	F-26
Tungsten sliding block.....	F-5
Marshall.....	2-7, 5-13
Measurement	
Asphalt.....	4-3
Density.....	4-1, A-2
Depth of.....	A-5
Moisture.....	4-1, A-5
Soil.....	4-2
Specifications.....	G-2
Storing.....	4-4
Unit conversion.....	2
Units.....	2-4
Mechanical	
Maintenance.....	F-4
Specifications.....	G-5
Memory	
Specifications.....	G-3
Memory Clear function.....	7-10
Metric units.....	2-4

Microsoft	
Excel.....	J-4
Windows	J-1
Word	J-4
Mode	
Asphalt	2-6, 4-3
Depth.....	5-22
Function	2-6
Ready	2-2
Soil	2-6, 4-2
Moisture	
Measurement	A-5
Measurements	4-1
Offset.....	5-5
Multiplication (calculator function).....	5-25

N

Neutron.....	C-2, B-2
Cross-sections	A-5
Thermalization	A-5
Neutron absorbers	5-5
NO/CE key	1-6
Nomograph function	6-15
Notice to Employees	D-3
Nuclear compaction test data	H-4

O

OFF key.....	1-6
Offset	
Density	5-4
Function	5-3
Moisture	5-5
Side wall.....	5-10
Trench	5-10
Wet density	5-4
ON key	1-6
Operation	
Gauge.....	5-1
Theory.....	A-1
Optional accessories.....	F-26

P

Parts	
Replacement.....	F-16
Personnel monitoring	D-2
Photons.....	C-2, A-2
Poisson distribution.....	B-4
Precision function	6-22
Print	
Function	5-18
Print function	5-18
Proctor values.....	5-13
Project	
Erase.....	2-10
Function	2-8
View.....	2-9
Proton.....	B-2

Q

Quality factor	B-5
----------------------	-----

R

Rad.....	B-5
Radiation	
Exposure	C-3
Gamma.....	C-2, A-2
Monitoring	C-4
Profile.....	C-4
Safety	C-1
Safety program.....	D-2
Statistics	B-4
Terminology.....	B-5
Theory	B-3, B-1
Types.....	C-2
Radiological	
Specifications.....	G-3
Unit conversion.....	2
Ready mode	2-2
Recall	
Function	5-22
Record keeping	D-4
Recover Erase function	6-9
Reference standard block.....	1-4, 2-13
Regulations	
Canadian shipping.....	E-4
U.S. shipping.....	E-2

Rem	B-5
Remote Control function	7-12
Replacement	
Gaskets	F-7
Parts	F-16
Returned Good Authorization (RGA)	F-27
Rod Length function	7-8
RS-232 serial port	5-18

S

SAFE position	2-13
Scraper plate/drill rod guide	1-4, 3-2
Scraper ring maintenance	F-5
Security	D-2
Serial Number function	7-4
Serial port	5-18
Service	
Centers	iii
Returning a gauge	F-27
Set Units function	2-4
Shielding	C-3
SHIFT key	1-6
Shipper's Declaration for Dangerous Goods	E-2
Shipping	
Canadian requirements	E-4
U.S. requirements	E-2
Shutdown, automatic	2-2, G-4
Side wall offset	5-10
Site preparation	3-1
Sliding block	
Cleaning	F-4
Maintenance	F-5
Soil	
Measurement	4-2
Mode	2-6, 4-2
Site preparation	3-2
Source	
Decay function	6-30
Encapsulation	C-6
Rod	2-13
Rod bearing maintenance	F-6
Rod inspection	F-4
Rod length	7-8
Rod positions	2-14

Special	
Calibration function	6-12
Functions.....	6-1
Roadway function	6-31
Specifications	G-1
Calibration.....	G-3
Electrical	G-4
Measurement.....	G-2
Mechanical.....	G-5
Memory.....	G-3
Radiological	G-3
Standard	
Count log.....	H-2
Standard count	2-13
START/ENTER key	1-6
Stat test.....	6-3
Station number	4-4
Status function	5-16
Store function.....	4-4
STORE key	4-4
Subtraction (calculator function).....	5-25

T

Test	
Drift.....	6-7
Leak	D-3
Stat	6-3
Theory, radiation.....	B-3, B-1
Thermalization	A-5
Thermoluminescent dosimeter (TLD).....	C-4
Time	
Count.....	2-5
Limiting radiation exposure	C-3
Time/Date function	2-11
Training	
Hazmat	E-3
Troxler course	D-3
Transport case	1-4
Transport Packaging of Radioactive Materials Regulations (TPRM)	E-4
Transportation	
Canadian requirements.....	E-4
U.S. requirements.....	E-2
Transportation and shipping.....	E-1
Transportation of Dangerous Goods Act and Regulations (TDG)	E-4
Trench offset	5-10
Troubleshooting	F-10

U

U.S. NRC 1-3
U.S. shipping requirements E-2
Unit conversion 1
Units
 Measurements 2-4
 Metric 2-4

V

View project 2-9
Voidless density value 5-13, 5-15
Voids
 Asphalt 3-4
 Soil or base 3-2

W

Warnings and cautions iv
Wet density offset 5-4

Y

YES key 1-6

NOTES

NOTES

WARRANTY

TROXLER ELECTRONIC LABORATORIES, INC.

LIMITED WARRANTY

TROXLER ELECTRONIC LABORATORIES, INC., and subsidiary, **TROXLER INTERNATIONAL, LTD.**, hereinafter referred to as "**TROXLER**" warrants this instrument, model 3440 serial number _____, against defects in material and workmanship for a period of 18 mos. from date of shipment. For gauges sold through authorized **TROXLER** representatives, the date of shipment will be as of the transfer from representative to purchaser. During the applicable warranty period, **TROXLER's** obligation under this warranty shall be limited exclusively to the repair, F.O.B. **TROXLER's** plant of any instrument which may prove defective under normal use and which **TROXLER's** examination shall disclose to its satisfaction to be thus defective, normal use being defined for the purpose of this warranty as operation under normal load, usage, and conditions with proper care and maintenance and competent supervision. In no event shall **TROXLER** be held liable for damages, delays, or losses consequential, incidental, or otherwise attributable to the failure of this instrument or radioactive material contained therein. **TROXLER's** liability being specifically limited to repair as stated hereinabove. This warranty is automatically initiated except where modified by contractual or other written and signed agreement.

THERE ARE NO WARRANTIES WHICH EXTEND BEYOND THE DESCRIPTION ON THE FACE HEREOF, AND THIS WARRANTY IS EXPRESSLY IN LIEU OF ALL OTHER WARRANTIES, EXPRESSED OR IMPLIED, AND TROXLER NEITHER ASSUMES, NOR AUTHORIZES ANYONE TO ASSUME FOR IT ANY OTHER LIABILITY IN CONNECTION WITH THE SALE OF THE INSTRUMENT. THIS WARRANTY SHALL NOT APPLY TO THE INSTRUMENT OR ANY PART WHICH HAS BEEN SUBJECTED TO DAMAGE BY ACCIDENT, NEGLIGENCE, ALTERATION, ABUSE, MISUSE, OR SERVICE NOT AUTHORIZED IN WRITING BY TROXLER. SUCH DAMAGE TO INCLUDE BUT NOT BE LIMITED TO BURNING OF CIRCUIT BOARDS AND HARNESS FROM IMPROPER SOLDERING TECHNIQUES AND DAMAGE TO THE INSTRUMENT DUE TO PURCHASER'S FAILURE TO PERFORM MAINTENANCE AS OUTLINED IN THE AUTHORIZED OPERATOR'S MANUAL. DUE TO THE NATURE OF THEIR USE, MECHANICAL ACCESSORY PARTS AND BATTERIES ARE WARRANTED FOR 90 DAYS FROM SHIPMENT DATE.

TROXLER ELECTRONIC LABORATORIES, INC.

Troxler International, Ltd.
Troxler Electronics (Canada), Ltd.
Troxler Electronics GmbH
3008 Cornwallis Road
Post Office Box 12057
Research Triangle Park, NC 27709 USA

NOTICE TO CONSUMERS

Any disclaimer or limitation on the remedies expressed above shall not be effective to the extent prohibited by state or federal law.

NOTE: THIS WARRANTY EXCLUDES DAMAGE INCURRED IN SHIPMENT. IF THIS CASE IS RECEIVED IN DAMAGED CONDITION, THE CARRIER SHOULD BE CONTACTED IMMEDIATELY. ALL CLAIMS FOR DAMAGE IN TRANSIT SHOULD BE FILED WITH THE CARRIER. IF REQUESTED, TROXLER WILL AID IN FILING OF CLAIMS AND/OR LOCATING GAUGES LOST IN TRANSIT.