

Manual of Operation and Instruction

Model 3450

RoadReader™ Plus

Surface Moisture-Density Gauge



Troxler Electronic Laboratories, Inc.

3008 Cornwallis Rd. • P.O. Box 12057

Research Triangle Park, NC 27709

Phone: 1.877.TROXLER

Outside the USA: +1.919.549.8661

Fax: +1.919.549.0761

www.troxlerlabs.com

Troxler gauges are protected by U.S. and foreign patents

Copyright ♥ 1996–2009

**Troxler Electronic Laboratories, Inc.
All Rights Reserved**

No part of this manual may be reproduced or transmitted in any form or by any means, electronic or mechanical, including photocopying, recording, or information storage and retrieval systems, for any purpose without the express written permission of Troxler Electronic Laboratories, Inc.

Fantastic is a trademark of Dow Consumer Products, Inc.

Federal Express is a registered trademark of the Federal Express Corporation.

409 is a trademark of the Clorox Company.

Magnalube-G is a registered trademark of Carleton-Stuart Corporation.

Microsoft, Excel, Windows, and Word are registered trademarks of Microsoft Corporation.

RoadReader is a trademark of Troxler Electronic Laboratories, Inc.

WD-40 is a registered trademark of the WD-40 Company.

PN 107837
January 2009
Edition 4.4



SAFETY ALERT SYMBOL



The Safety Alert Symbol shall appear within this manual. Wherever it appears in this manual or on safety signs affixed to the machine, this is to make all aware of the potential for personal injury and to be cautious when these images are present.

Always observe all **WARNING**, **CAUTION**, and **NOTE** recommendations listed within this manual before operating the machine.



TROXLER SERVICE CENTERS

Troxler Corporate Headquarters

3008 Cornwallis Road
P.O. Box 12057
Research Triangle Park, NC 27709
Phone: 1.877.TROXLER (1.877.876.9537)
Outside the U.S.A.: +1.919.549.8661
Fax: +1.919.549.0761
Web: www.troxlerlabs.com

Technical Support

Phone: 1.877.TROXLER (1.877.876.9537)
E-mail: TroxTechSupport@troxlerlabs.com

Florida Service Center

2376 Forsyth Road
Orlando, FL 32807
Fax: 407.681.3188

Texas Service Center

2016 East Randol Mill Road
Suite 406
Arlington, TX 76011
Fax: 817.275.8562

Illinois Service Center

1430 Brook Drive
Downers Grove, IL 60515
Fax: 630.261.9341

Northern California Service Center

11300 Sanders Drive, Suite 7
Rancho Cordova, CA 95742
Fax: 916.631.0541

Troxler European Subsidiary

Troxler Electronics GmbH
Gilchinger Strasse 33
D.82239 Alling nr. Munich, Germany
Phone: ++49.8141.71063
Fax: ++49.8141.80731
E-mail: troxler@t-online.de

NOTE

To locate an independent, Troxler-authorized service center near you, call 1.877.TROXLER (1.877.876.9537).

HOW TO USE THIS MANUAL

Congratulations on the purchase of the **Troxler Model 3450 RoadReader Plus**. Troxler continues the proven technology of its 3400 Series surface moisture-density gauges with the Troxler Model 3450 RoadReader Plus.

The *Model 3450 Manual of Operation and Instruction* contains information on safely using this gauge. Also included in this manual are safety warnings, gauge setup, troubleshooting, and general maintenance.

CONVENTIONS USED IN THIS MANUAL

Throughout this manual, symbols and special formatting are used to reveal the purpose of the text as follows:

WARNING

Indicates conditions or procedures that, if not followed correctly, may cause personal injury.

CAUTION

Indicates conditions or procedures that, if not followed correctly, may cause equipment damage.

NOTE

Indicates important information that must be read to ensure proper operation.

⟨KEY⟩

Angle brackets and a different typestyle indicate a key or character (number or letter) to press on the gauge keypad. For example, “Press ⟨**START**⟩” means to press the key labeled *START*.

DISPLAY

A different typestyle is used in text to indicate information or messages displayed on the gauge.

**DISPLAY - Typestyle
and shading used to
simulate the gauge
display**

- ◆ Diamonds indicate a list of things needed (such as equipment) or things to know.
- ✓ Check marks indicate the performance of an action. With lists of check marks, follow the instructions in the order of the check marks.
- ▶ Triangles indicate that more than one option is available. Carefully select the option that applies.

NOTES

TABLE OF CONTENTS

CHAPTER 1. INTRODUCTION TO THE MODEL 3450

Introduction.....	1-2
Gauge Parts and Accessories	1-4
Unpacking and Inspection	1-6

CHAPTER 2. THEORY OF OPERATION

Density	2-2
Moisture	2-3
Thin Layer	2-5
Calibration	2-6

CHAPTER 3. GETTING STARTED

Model 3450 Illustration	3-2
Keypad.....	3-3
Source Rod Positions	3-5
Daily Inspection.....	3-6
Turning the Gauge On	3-7
Setup	3-9

CHAPTER 4. USING THE GAUGE

Taking a Standard Count	4-2
Preparing a Test Site.....	4-6
Taking Measurements.....	4-9

CHAPTER 5. PROJECT DATA

Separating the Control Unit	5-2
Handling Project Data.....	5-5
Storing Data	5-10

CHAPTER 6. ADJUSTING MEASUREMENTS

Calibration Offset	6-2
Special Calibration.....	6-11

APPENDIX A. RADIATION THEORY AND SAFETY

Radiation Theory	A-2
Radiation Safety.....	A-5
Regulatory Requirements	A-15
Gauge Use Precautions	A-18
3450 Radiation Profile	A-19

TABLE OF CONTENTS (Continued)

APPENDIX B. 3450 SPECIFICATIONS

Measurement Specifications.....	B-2
Radiological Specifications.....	B-5
Electrical Specifications	B-6
Mechanical Specifications.....	B-8

APPENDIX C. TROUBLESHOOTING AND SERVICE

Stat Test.....	C-3
Drift Test	C-5
Source Decay.....	C-8
Troubleshooting.....	C-9
Batteries.....	C-18
Mechanical Maintenance.....	C-22
Leak Testing	C-25
Display Contrast.....	C-27
Replacement Parts	C-28
Returning the Gauge for Service	C-30

APPENDIX D. TRANSPORTATION AND SHIPPING

U.S. Shipping Requirements	D-2
Canadian Shipping Requirements	D-4

APPENDIX E. STANDARD COUNT LOG

APPENDIX F. UNIT CONVERSION

Measurement Units.....	F-2
Radiological Units.....	F-2

APPENDIX G. SPECIAL EUROPEAN CONSIDERATIONS

Declaration of Conformity	G-2
Safety Warnings	G-3

APPENDIX H. PRINTING (UPLOADING) PROJECT DATA

Windows Hyperterminal	H-2
Viewing Project Data	H-5

INDEX

WARRANTY

LIST OF FIGURES

<u>Figure</u>	<u>Title</u>	<u>Page</u>
1-1	Model 3450 Parts and Accessories.....	1-4
2-1	Effect of Moisture on Depth of Measurement.....	2-4
3-1	Model 3450 Illustration.....	3-2
3-2	Model 3450 Keypad.....	3-4
3-3	Source Rod Positions	3-5
4-1	Standard Count Position.....	4-3
4-2	Drill Rod Assembly.....	4-7
4-3	Marking the Test Area.....	4-7
4-4	Gauge Positioned Around a Core Site.....	4-14
4-5	Gauge Positioned Over Designated Test Site.....	4-15
6-1	Gauge Positioned Over Designated Test Site.....	6-13
6-2	Taking Measurements Around a Core Site	6-17
A-1	Diagram of an Atom.....	A-2
A-2	Effect of Distance on Exposure.....	A-7
A-3	Cleaning the Sliding and Fixed Blocks	A-12
A-4	Performing a Leak Test	A-14
A-5	Model 3450 Gauge and Transport Case	A-19
C-1	Replacing NiCad Battery Pack.....	C-21
C-2	Display Contrast Adjustment	C-27

LIST OF TABLES

<u>Table</u>	<u>Title</u>	<u>Page</u>
3-1	Model 3450 Keypad Functions.....	3-3
A-1	Radiation Profile for Model 3450 Gauge.....	A-20

ATTENTION 3450 GAUGE OWNER

*This unit contains functions that require an ACCESS CODE.
This code must be entered before these functions may be used.*

The ACCESS CODE for this gauge is:

4698

This page should be removed if the access code is not to be distributed to other parties or users of this gauge.

NOTES

CHAPTER 1

INTRODUCTION TO THE MODEL 3450

This chapter provides a brief overview of the Troxler Model 3450 RoadReader[®] Plus, and includes a list of the gauge parts and accessories, and instructions for unpacking and inspecting the gauge.

CONTENTS

Introduction.....	1-2
Gauge Parts and Accessories	1-4
Unpacking and Inspection	1-6

INTRODUCTION

Troxler has combined the proven technology of its 3400 (moisture/density) and 4640 (thin layer density) gauges to produce the Troxler Model 3450 RoadReader Plus. The 3450 meets or exceeds all applicable American Society of Testing and Materials (ASTM) standards (or corresponding equivalent), including:

- ◆ *ASTM D-2922: Standard Test Methods for Density of Soil and Soil-Aggregate in Place by Nuclear Methods (Shallow Depth).*
- ◆ *ASTM D-2950: Standard Test Method for Density of Bituminous Concrete in Place by Nuclear Method.*
- ◆ *ASTM D-3017: Standard Test Method for Water Content of Soil and Rock in Place by Nuclear Methods (Shallow Depth).*

With the 3450, the operator can quickly and precisely measure the moisture content and density of construction materials. The gauge's features include:

- ◆ Three measurement modes (*soil, asphalt, and thin layer*) for precise compaction control readings in most construction materials:
 - Soil Mode:** For moisture/density determinations in soil, soil-stone materials in layers of 4 inches or greater.
 - Asphalt Mode:** For density determinations in asphalt or hardened concrete layers of 4 inches or greater.
 - Thin Layer Mode:** For density determinations in asphalt layers of less than 4 inches.
- ◆ Special calibration offsets (*wet density, moisture, and trench*) to expand measurement possibilities, and to enhance gauge readings on materials that may fall outside the range of factory calibration.
- ◆ Over 30 functions to facilitate all phases of testing compaction on construction materials.
- ◆ A backlit liquid crystal display (LCD) to help the operator read the display during night construction.

- ◆ Easy-to-use keypad and user-friendly menus to reduce training time to increase productivity.
- ◆ Removable keypad assembly to allow the operator to upload data to a PC without taking the gauge into the office.

Any licensing issues discussed in this manual are for the United States. To purchase a Model 3450 in Canada, owners must obtain a radioisotope license from the Canadian Nuclear Safety Commission (CNSC). The owner should obtain copies of the CNSC Regulations and the *Transportation of Dangerous Goods Act and Regulations* (TDG). For other countries, please consult your local regulatory agency.

Owners are encouraged to require study of this manual before allowing anyone to use the gauge. ***A potential hazard does exist if improperly used.*** Appendices A and D, which cover radiological safety, should be required reading for all users and potential users. **If these appendices are not completely understood, users should seek assistance from Troxler, an appointed Troxler representative, or others designated within the user's organization.**

Additional radiation safety information is available by attending a Troxler Nuclear Gauge Training Course.

Before operating the 3450 gauge, users in European countries must refer to Appendix G for special considerations, additional safety warnings, and the Declaration of Conformity.

Since changes are made to local, state, and federal regulations on a continuing basis, the owner/operator must maintain awareness of current requirements. *The responsibility for compliance ultimately falls on the owner.* An owner in the United States may also wish to purchase and subscribe to Titles 10 and 49 of the *Code of Federal Regulations* (CFR) in addition to applicable local/state regulations.

GAUGE PARTS AND ACCESSORIES

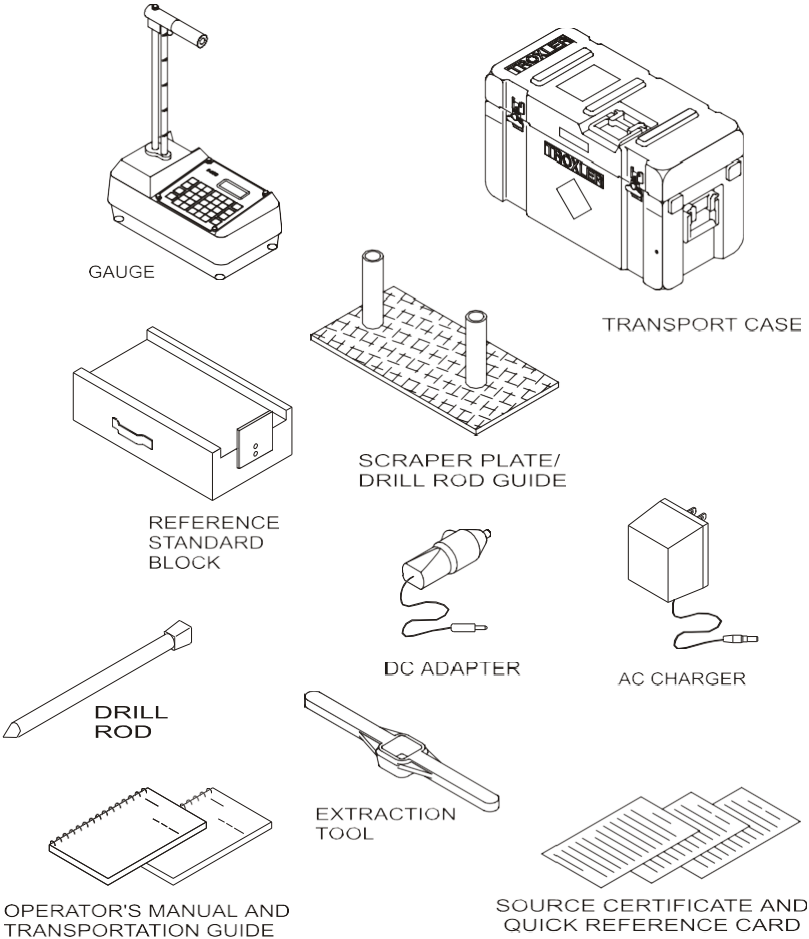

Figure 1–1. Model 3450 Parts and Accessories

1. The **Gauge** is the portable instrument containing all electronic modules, the rechargeable battery pack, detectors, and the radioactive sources.
2. The **Reference Standard Block** provides a measurement standard for standard counts. It is also used during stability and drift tests.
3. The **Drill Rod** is used to drill holes for direct transmission measurements. *Do not use the source rod of the gauge to drill holes.*
4. The **Scraper Plate/Drill Rod Guide** is used to prepare the test site and to guide the drill rod when preparing the source rod hole for direct transmission measurements.
5. The **Extraction Tool** provides leverage to remove the drill rod from soil materials.
6. The **AC Charger** and **DC Adapter** are used to charge the gauge batteries. The ac charger accepts 110 (220 and European optional) V ac, 50/60 Hz and supplies 12 V dc. The dc adapter allows recharging from an automobile cigarette lighter.
7. The **Transport Case** for the Model 3450 is a Type A package. Always use a Type A package to ship the Model 3450.
8. The **Manual** details how to use the gauge. Both the manual and the **Transportation Guide** discuss radiation safety and gauge shipping concerns.
9. A **Printer** (optional, not shown) connects to the gauge for printing data.
10. A **Printer Cable** (optional, not shown) is used to connect the gauge to a serial printer or computer.

UNPACKING AND INSPECTION

Troxler recommends that the operator wear a dosimeter while working with the gauge. Upon receipt of the gauge from the factory, perform a complete inspection and inventory. If the shipping case and/or any other part or accessory appears damaged, notify the carrier and your Troxler Representative **immediately**.

For shipping to another location or back to the factory, save the box and any packing material. For shipping instructions and regulations, please see Appendix D.

Check the shipping case for the following:

- ◆ Model 3450 Gauge
- ◆ Reference Standard Block
- ◆ Drill Rod
- ◆ Scraper Plate/Drill Rod Guide
- ◆ Extraction Tool
- ◆ AC Charger
- ◆ DC Adapter (for a vehicle cigarette lighter)
- ◆ Manual of Operation and Instruction
- ◆ Gauge Warranty
- ◆ Source Certificate
- ◆ Transportation Guide (This guide refers to U.S. standards. All other countries please refer to local regulations. In the absence of local regulations, please use this guide as a reference only)

NOTE

Charge the batteries for four hours prior to initial use.

Lift the gauge from the transport case and inspect the outside surface for damage. Check the lock on the source rod handle and make sure the keys fit. Remove the lock, release the trigger, and check the source rod operation. It should move up and down with little effort. Return the gauge to the transport case.

CHAPTER 2

THEORY OF OPERATION

This chapter provides a brief description of the theory of operation of the Troxler Model 3450 RoadReader Plus. The *direct transmission* and *backscatter* modes of operation are illustrated, along with an explanation of the cesium-137 source, americium-241:beryllium source, and detector geometry.

CONTENTS

Density	2-2
Moisture	2-3
Thin Layer	2-5
Calibration	2-6
Offsets	2-6

DENSITY

The Troxler Model 3450 RoadReader Plus uses two modes of operation: *direct transmission mode* (with the source rod extended into the material to be measured) and *backscatter mode* (with the source rod in the backscatter position). Source rod positions are described in Chapter 3.

In the direct transmission position, the source rod extends through the base of the gauge into a pre-drilled hole to a desired depth. Photons from the cesium-137 (Cs-137) source in the source rod pass through the test material. While passing through the test material, the photons collide with electrons and lose energy. A high material density increases the probability of these photon collisions. This decreases the number of photons that reach the Geiger-Mueller (G-M) detectors in the base of the gauge. Thus, the number of photons reaching the detectors is inversely related to the density of the material: the higher the density of the material, the fewer the photons that reach the detectors. Using the gauge calibration, the gauge software converts the G-M detector counts to a density value.

In the backscatter position, the source rod is lowered to the first notch below the **SAFE** (shielded) position. This places the source and the detectors in the same plane. Shielding between the source and detectors greatly reduces the number of photons reaching the detectors in a direct path from the source. Thus, the photons from the Cs-137 source must travel into the test material and scatter (or reflect) at least once to reach the G-M detectors. The detectors in the gauge base count these scattered photons. For *thin layer* readings, the gauge uses two sets of G-M detectors. Refer to the *Thin Layer* section on page 2–5.

MOISTURE

The Model 3450 uses the principle of neutron *thermalization* to monitor the moisture content of a material. The gauge includes an americium-241:beryllium (Am-241:Be) source that is fixed in the gauge's base. Fast neutrons emitted by the Am-241:Be source pass into the test material. Multiple collisions between the fast neutrons and a similarly sized mass (such as the nuclei of hydrogen atoms) cause the neutrons to slow to the point where further collisions with hydrogen or other materials will not continue to reduce the neutron energy further. These neutrons are said to have been *thermalized*.

The 3450 gauge contains a helium-3 detector that is sensitive only to thermalized, or "slow," neutrons. As a result, the moisture counts relate directly to the amount of hydrogen in the material. Using the gauge calibration, the gauge software converts the helium-3 detector counts to a moisture content. (Note that the helium-3 detector is in the same plane as the Am-241:Be source. Therefore, moisture measurement is similar to a density measurement taken in backscatter mode, as described earlier in this chapter.)

The *depth of measurement* is defined in terms of a maximum depth beneath the surface of the material being measured. Of the neutrons counted by the gauge, 98 percent will penetrate no deeper than the depth of measurement. The depth of measurement is a function of moisture content. The following equations can be used to determine the approximate depth of measurement.

$$\text{Depth (inches)} = 11 - (0.17 \times M), \text{ where: } M = \text{moisture in pcf}$$

or

$$\text{Depth (mm)} = 280 - (0.27 \times M), \text{ where: } M = \text{moisture in kg/m}^3$$

The normalized curve set shown in Figure 2–1 illustrates the effects of moisture content on the depth of measurement.

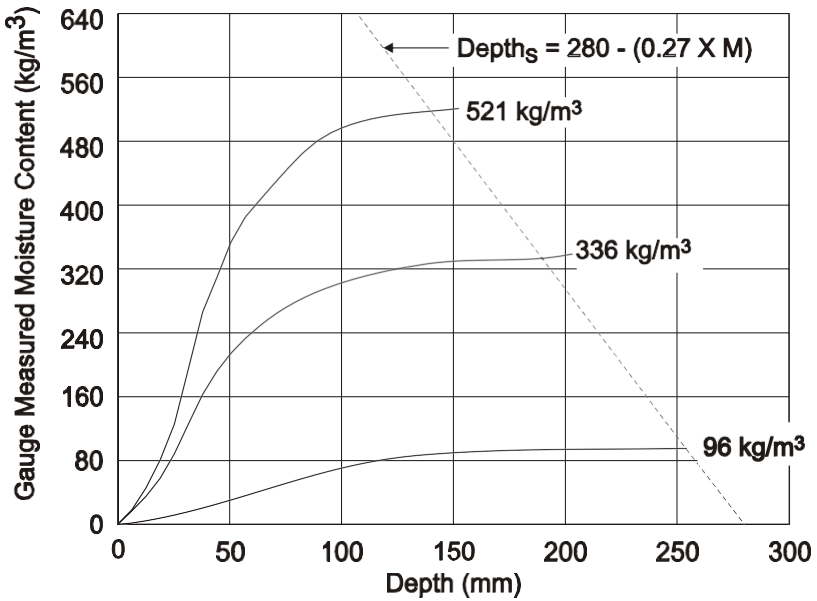
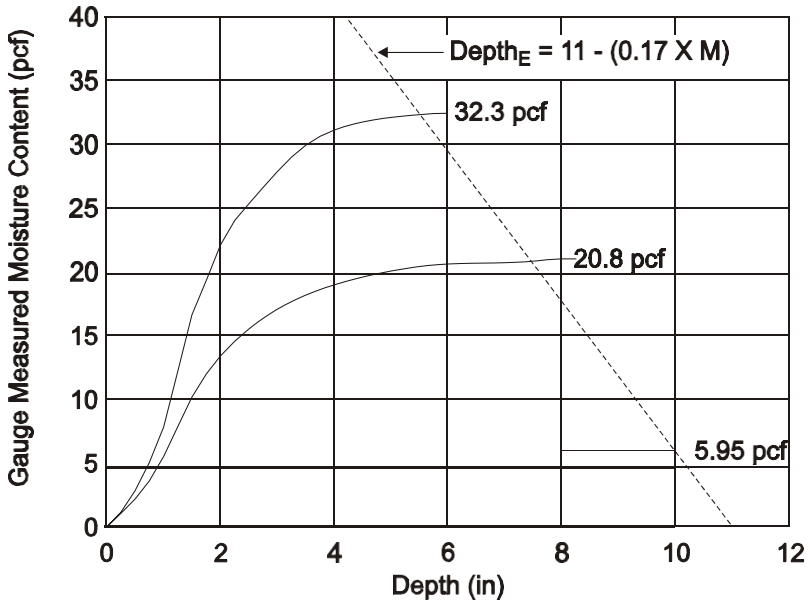

Figure 2-1. Effect of Moisture on Depth of Measurement

THIN LAYER

The Model 3450 contains two sets of G-M tubes for photon detection. The set closest to the source rod is referred to as *System 1*, while the set farthest from the source rod is *System 2*. When the source rod is in the backscatter position, the source and the detectors are on approximately the same plane.

Both System 1 and System 2 tube sets will primarily detect photons that have been scattered by the material as described in the *Density* theory of operation (see page 2–2). However, due to its greater distance from the source, System 2 is more likely to detect scattered photons from deeper in the material than is System 1. The difference in the depth of material measured by each system, the factory calibration, and mathematical modeling allow the 3450 gauge to determine the density of the top layer of material.

CALIBRATION

Troxler calibrates the 3450 gauge at the factory. The operating range of the gauge is from 1100 to 2700 kg/m³ (70 to 170 pcf).

Troxler also calibrates the Model 3450 for thin layer measurements. The thin layer factory calibration covers a thickness range of 2.5 to 10 cm (1.0 to 4.0 in.).

OFFSETS

The factory calibration provides accurate results for the majority of materials found in the field. If the gauge is to be used to test materials not covered by the factory calibration, the readings can be adjusted using either an *offset* as described below or a *special calibration* as described in Chapter 6.

Perform a *wet density offset* if the test material is outside the density range for average soil or if the material composition varies from average soil/asphalt. Perform a *moisture offset* if the test material contains hydrogenous materials other than water or materials that absorb neutrons. Materials such as cement, gypsum, coal, mica, and lime are all hydrogenous. Material such as boron and cadmium are neutron absorbers.

Vertical structures scatter neutrons and gamma photons back to the gauge. This could result in inaccurate moisture and density readings. To take readings in a trench or within 0.6 m (2 ft) of a large vertical structure, perform a *trench offset*.

If the composition of the test material differs greatly from average soil and an offset does not provide adequate measurement accuracy, then the gauge may need to be calibrated. A special calibration allows the operator to calculate new calibration constants. For more information on the *Special Calibration* feature, see Chapter 6.

CHAPTER 3

GETTING STARTED

This chapter provides details on getting started with the Troxler Model 3450 RoadReader Plus. It describes the 3450 keypad, and provides instructions for conducting daily gauge inspections, turning the gauge on, and setting up the gauge.

CONTENTS

Model 3450 Illustration	3-2
Keypad.....	3-3
Source Rod Positions	3-5
Daily Inspection.....	3-6
Turning the Gauge On	3-7
Setup	3-9
Current Status (Special Key).....	3-9
Gauge Setup (Special Key)	3-10
Time/Date (Special Key).....	3-11
Printer (Special Key).....	3-13
Depth Indicator (Special Key).....	3-14
Beeper Level (Special Key)	3-15
Display Backlight.....	3-15
Sleep Mode/Display Timeout (Special Key).....	3-17
Battery Status (Special Key)	3-17
Set Units (Special Key).....	3-18
Customer Name (Special Key).....	3-18
Count Time.....	3-19
Target	3-19
Measurement Mode.....	3-23
QA Sampling (Special Key).....	3-24
Number Averages (Special Key).....	3-26
% Air Voids (Special Key).....	3-27

MODEL 3450 ILLUSTRATION

Figure 3–1 illustrates various components of the Model 3450 RoadReader Plus referred to throughout this chapter and the remainder of the manual.

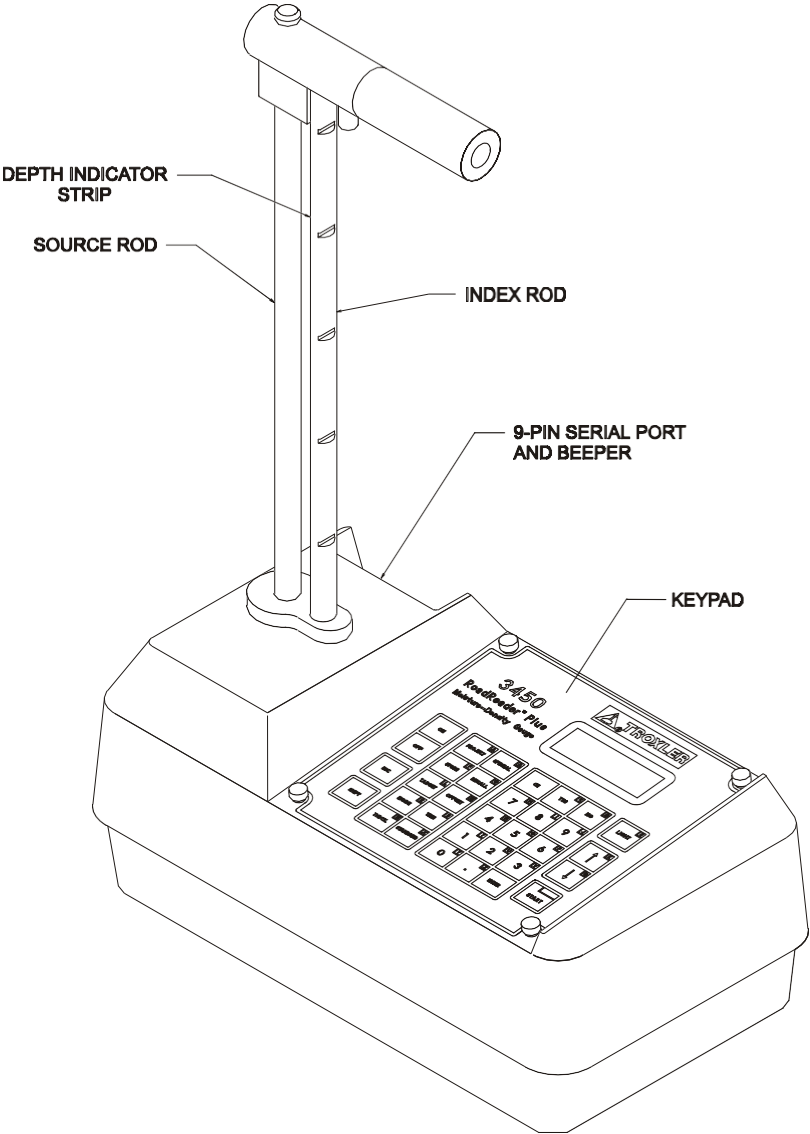

Figure 3–1. Model 3450 Illustration

KEYPAD

The Model 3450 keypad (Figure 3–2) allows the operator to access the gauge software. Troxler designed the keypad for ease of use, with large keys and an anti-glare coating. Pressing a function key activates the function only if the gauge is in the *Ready* mode. Table 3–1 describes the function of each key.

Table 3–1. Model 3450 Keypad Functions

KEY	FUNCTION
⟨ON⟩	Turn on the gauge display. Allows the operator to use the gauge after a quick self-test. (When prompted, press ⟨ENTER⟩ to go to the <i>Ready</i> mode screen.)
⟨OFF⟩	Turn off the gauge.
⟨ESC⟩	Return the display to the <i>Ready</i> screen without storing or updating the data.
⟨SHIFT⟩	Access the yellow letters and Space key.
⟨PROJECT⟩	Select or create a project file and view, print, or erase project data file.
⟨SPECIAL⟩	Access the <i>Special</i> function menu.
⟨STORE⟩	Store the most recent data in the current project file.
⟨RECALL⟩	Display the most recent data.
⟨TARGET⟩	Select, enter, or disable a Proctor, Marshall, or Voidless density value.
⟨OFFSET⟩	Enable, disable, or change a wet density, moisture, or trench offset.
⟨MODE⟩	Select the measurement mode. The gauge offers three measurement modes: <i>Soil</i> , <i>Asphalt</i> , and <i>Thin Layer</i> .
⟨TIME⟩	Select the count time.
⟨THICKNESS⟩	Enter the surface lift thickness when measuring in the <i>Thin Layer</i> mode.
⟨STANDARD⟩	Take a standard count or view existing standard counts.
⟨CE⟩	Clear the last data entered or, if no data was entered, returns to the <i>Ready</i> screen.

Table 3–1. Model 3450 Keypad Functions (Continued)

KEY	FUNCTION
⟨YES⟩	Respond yes to yes/no questions.
⟨NO⟩	Respond no to yes/no questions.
⟨0⟩ .. ⟨9⟩	Enter numbers and access menu options.
⟨.⟩	Enter a decimal point.
⟨LIGHT⟩	Manually turn on the LCD backlight feature.
⟨↑⟩, ⟨↓⟩	Scroll through menu options or view screens.
⟨ENTER⟩	Accept data entry.
⟨START⟩	Begin a measurement.
⟨A⟩ .. ⟨Z⟩, ⟨SPACE⟩	Enter letters or a space. Access these keys by first pressing ⟨SHIFT⟩.

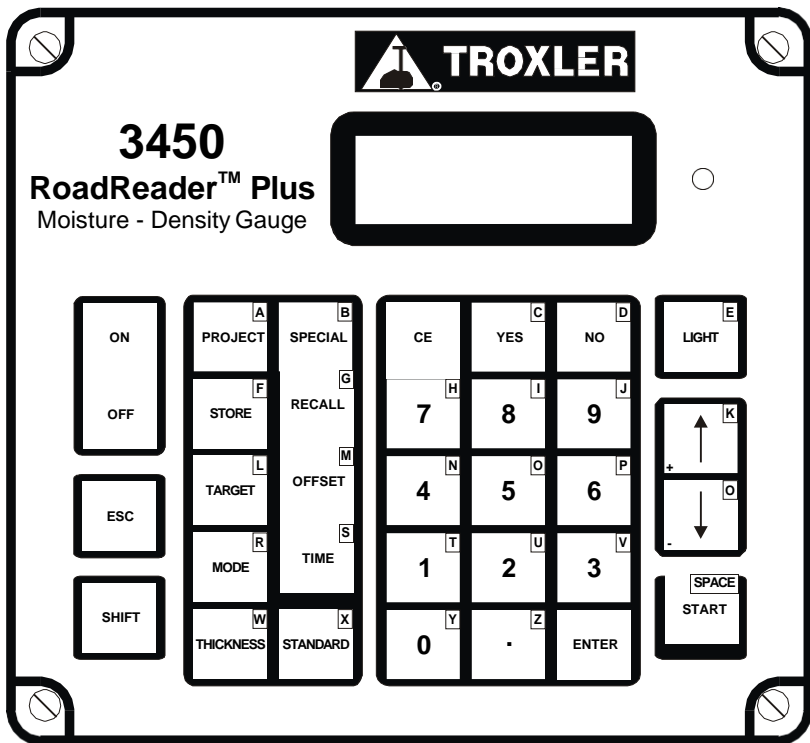
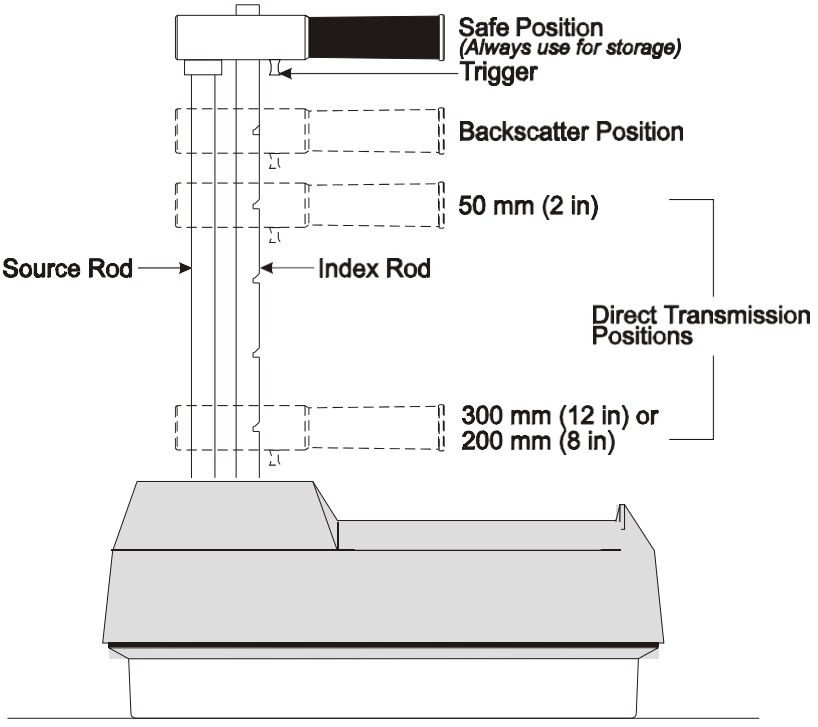

Figure 3–2. Model 3450 Keypad

SOURCE ROD POSITIONS

As shown in Figure 3–3, the source rod can be placed in the **SAFE**, backscatter, or direct transmission positions. When not taking measurements, keep the source rod in the **SAFE** position. When measuring thin layer or other materials through which you cannot drill a hole, use the backscatter position. In the direct transmission positions, the source rod extends into a pre-drilled hole.

NOTE
The source rod should always be in the **SAFE** position when the gauge is not in use.



3. GETTING STARTED

Figure 3–3. Source Rod Positions
(Maximum Depth of 300 mm in Increments of 50 mm)

DAILY INSPECTION

The gauge should be inspected daily before use to ensure proper operation of all safety features. Refer to page A-10 for the daily inspection procedure.

TURNING THE GAUGE ON

To turn on the gauge, press the **<ON>** key. The gauge will briefly display the model number and software version. The software then performs two tests to ensure that the gauge is working properly. First, the software tests the display. Second, the gauge performs a self-test. After the self-test, the gauge displays the battery status, as shown:

```
Charger - OFF
Ni-Cad - In Use
Alkaline - Ready
Press ENTER
```

The first line indicates if the charger is connected. The next two lines show the status of the NiCad batteries and the alkaline batteries. On these lines, the gauge will display if either set of batteries is low or missing. To view the battery voltage, press the **<↓>** key. To continue, press the **<ENTER>** key.

The gauge enters a warmup period. During this period, the gauge displays:

```
Gauge Warm Up
Please wait...
```

Following the warmup period, the gauges displays the *Ready* screen:

```
-READY- ASPH Mode
Depth-STD 10:21 am
Tim-60sec 02/28/2001
PR#: Your Project
```

The operator can access any gauge function from the *Ready* screen. The *Ready* screen displays the measurement mode on the first line. The second line shows the source rod depth and date. The third line shows the count time and time of day. The last line shows the current project (if any).

NOTE

If the gauge display is difficult to read in bright light, adjust the contrast as described in the *Display Contrast* section on page C-27.

To conserve power, the Model 3450 gauge provides a *sleep* mode (see page 3-17). In *sleep* mode, the display and most of the electronics are turned off. If the gauge is not in use for a period of time, it will enter sleep mode. All data and settings are protected. To turn the display on when in sleep mode, press any key (other than the **<ON>** or **<OFF>** keys).

Before taking measurements, read this manual carefully. If you do not completely understand the sections that cover radiation safety, contact your company radiation safety officer (RSO) or the nearest Troxler representative.

SETUP

After turning the gauge on for the first time, set up the software. The gauge stores the software setup, so the operator does not need to enter a new setup each time the gauge is turned on. Although the values noted below may be changed at any time.

The Model 3450 offers a *Current Status* feature that enables the operator to view the current gauge status, setup, and constants; and to print the current gauge status and calibration constants. The gauge *status* includes the customer name, software version, units, count time, measurement mode, Marshall value, Proctor value, Voidless density value, measurement mode status, percent air voids status, specific gravity, offset status, offset values, printer setup, and special calibration. The gauge *setup* includes the software version, gauge serial number, source rod type, last reset date, charger and battery status, display time out, backlight setup, beeper setup, and depth indicator setup. The *constants* include calibration constants and status.

NOTE

The *Special* key contains several functions. These functions are typically not used on a day-to-day basis. The features that are accessed through the *Special* key are denoted in this chapter with the phrase (*SPECIAL KEY*) in the section title.

CURRENT STATUS (SPECIAL KEY)

Access the *Special* functions menu by pressing the **(SPECIAL)** key. At the *Special* functions menu, press **(2)** *Gauge Status/Test* to access the *Gauge Status/Test* menu. At the *Gauge Status/Test* menu, press **(1)** *Current Status*. From this menu, press **(1)** *View Status*.

- | |
|--|
| <ol style="list-style-type: none">1- View Status2- View Setup3- View Constants4- Print Status |
|--|

Before selecting **<4>** *Print Status*, check the printer setup (see page 3–13).

On any given screen, there may be more information than can display on a single screen. These screens are indicated with an up/down arrow in the top, right corner. To scroll through the displays, use the keypad's arrow keys. Return to the *Ready* screen by pressing the **<ESC>** key.

GAUGE SETUP (SPECIAL KEY)

The Model 3450 software groups all the setup features in one menu. To access the *Gauge Setup* menu, press the **<SPECIAL>** key, then select **<4>** *Gauge Setup*.

- 
- 1- Set Time/Date**
 - 2- Print Set-Up**
 - 3- Depth Indicator**
 - 4- Set Beeper Level**

To scroll through the *Gauge Setup* menu, use the arrow keys (screens that have options the operator can scroll through are indicated with the up/down arrow symbol in the upper right corner of the screen). To select a menu option, use the number key that corresponds to the option. The remainder of this section provides details on the setup options.

TIME/DATE (SPECIAL KEY)

The *Time/Date* setup option allows the operator to change the time, date, and time/date display format. To access the feature, press **⟨1⟩** *Set Time/Date* at the *Gauge Setup* menu (see previous page).

This option requires an access code. At the gauge prompt, use the number keys to enter the access code (see page xi).

The gauge displays the *Time/Date* menu:



**1- Change Time
2- Change Date
3- Change Format
ENTER for Setup**

From this screen, the operator may change the time, date, or time/date display format. To select a menu option, use the number keys. To return to the *Gauge Setup* menu, press the **⟨ENTER⟩** key.

Time

To change the time, press **⟨1⟩** at the *Time/Date* menu. If displaying the time in the AM/PM format, the display is:

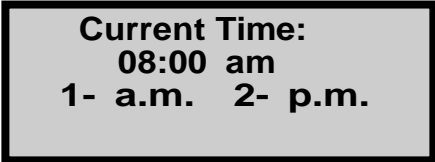

**Current Time:
08:00 am
1- a.m. 2- p.m.**

With either display format option, the control unit requests the current time. Press the **⟨1⟩** key for *a.m.* or **⟨2⟩** for *p.m.* Use the number keys to enter the correct hour and minutes, then press the **⟨ENTER⟩** key.

The gauge updates the time and returns to the *Time/Date* screen. To return to the *Gauge Setup* menu, press the **⟨ENTER⟩** key. To return to the *Ready* screen, press the **⟨ESC⟩** key.

Date

From the *Time/Date* menu on the previous page, change the date by selecting **<2>** *Change Date*.



**Current Date:
02/28/2002
Input Date
Then Press ENTER**

Use the number keys to enter the correct month and year, then press the **<ENTER>** key. (This example uses the *mm/dd/yyyy* format. The format can be changed to *dd/mm/yyyy*, as described in the following section.)

The gauge updates the date and returns to the *Time/Date* screen.

To return to the *Gauge Setup* menu, press the **<ENTER>** key. Return to the *Ready* screen by pressing the **<ESC>** key.

Format

From the *Time/Date* menu, change the time/date format by pressing **<3>** *Change Format*.

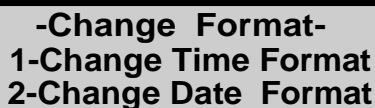

**-Change Format-
1-Change Time Format
2-Change Date Format**

Change the time format (*a.m./p.m.* or *24 hours*) by pressing **<1>** and selecting the format. Change the date format (*mm/dd/yyyy* or *dd/mm/yyyy*) by pressing **<2>** and selecting the format.

The gauge changes the display format and returns to the *Time/Date* screen. To return to the *Gauge Setup* menu, press the **<ENTER>** key. Return to the *Ready* screen by pressing the **<ESC>** key.

PRINTER (SPECIAL KEY)

The *Printer Set-Up* feature allows the operator to set up the gauge to communicate with an RS-232C serial device such as a printer or computer. See Chapter 5 and Appendix C for information on how to print data.

To access the *Printer Set-Up* feature, press **<2>** *Print Set-Up* at the *Gauge Setup* menu shown on page 3-9.

Serial Port Set-Up
1-32 Column
2-Spreadsheet

Using the number keys, select a menu option. The *32-column* option presents information in a non-delimited, narrative format. The *spreadsheet* format creates comma-delimited output.

After the serial port setup is selected, the gauge prompts the operator for the communication protocol. To select a protocol, use the number keys. After the protocol is selected, the gauge displays:

Baud Rate=9600
1- 300 **4- 2400**
2- 600 **5- 4800**
3- 1200 **6- 9600**

The gauge displays the current baud rate setting on the first line. To select a baud rate, use the corresponding number key.

The gauge changes the baud rate and returns to the *Gauge Setup* menu. Return to the *Ready* screen by pressing the **<ESC>** key.

To connect the gauge to a serial printer, unscrew the cover from the 9-pin serial port on the back of the gauge. Connect a serial printer cable to the gauge serial port. Connect the serial printer cable to the printer (or computer) serial port.

Serial data can also be sent with the control unit separated from the gauge base. Refer to the *Separating the Control Unit* section on page 5-2.

DEPTH INDICATOR (SPECIAL KEY)

The *Depth Indicator* feature allows the operator to set the depth mode and to calibrate the depth indicator. The depth mode tells the gauge how it will receive data about the source rod depth. The Model 3450 offers two depth modes: automatic and manual. In the automatic mode, the gauge software reads a depth strip on the index rod to determine the source rod depth. In the manual mode, the operator enters the source rod depth at a gauge prompt whenever taking a measurement.

To access the *Depth Indicator* menu, press **<3>** at the *Gauge Setup* menu shown on page 3–9.

**-Depth Indicator-
1- Automatic
2- Manual
3- Calibrate Depth**

To select a depth mode, press either **<1>** *Automatic* or **<2>** *Manual*.
To calibrate the depth strip, press **<3>** *Calibrate Depth*.

After the depth mode is selected, the gauge sets the mode and returns to the *Gauge Setup* menu. To return to the *Ready* screen, press the **<ESC>** key.

To calibrate the depth strip, press **<3>** and follow instructions on the gauge screen.

BEEPER LEVEL (SPECIAL KEY)

The *Beeper Level* feature allows the operator to adjust the loudness of the beeper. To access this feature, press **(4)** *Set Beeper Level* at the *Gauge Setup* menu shown on page 3–9.

Set Beeper Level:
1- Soft 2- Loud
3- Extra Loud

To select a menu option, use the corresponding number key. The *loud* setting uses the external beeper. To further control the external beeper, the operator can manually adjust the opening of the beeper located on the back of the gauge.

NOTE

Using the external beeper reduces the battery life.

The gauge changes the loudness of the beeper and returns to the *Gauge Setup* menu. To return to the *Ready* screen, press the **(ESC)** key.

DISPLAY BACKLIGHT

The Model 3450 provides a *backlight* option for the liquid crystal display (LCD). The backlight can help the operator read the display at night. Using the backlight reduces battery life; therefore, the gauge offers four backlight modes. The operator can set the gauge to activate the backlight:

1. Only after the operator presses the **(LIGHT)** key
2. After a count
3. After a keypress
4. After either a count or a keypress

The operator can also set how long the display remains backlit.

NOTE

Using the display backlight reduces the battery life. The display backlight operates only from the charged NiCad batteries. If the NiCad batteries are not charged, or if the control unit is disconnected from the gauge, the gauge uses the alkaline batteries, and therefore the backlight will not operate.

To set up the *backlight* option, press **<5>** *LCD Backlight* at the *Gauge Setup* menu shown on page 3–9 (use the arrow keys to scroll to the *LCD Backlight* menu). The gauge displays the four backlight modes, as shown:

- 1- Manual Only**
- 2- After Count**
- 3- After Keypress**
- 4- After Key & Count**

To use the backlight only when the **<LIGHT>** key is pressed, select **<1>**. To use the backlight after a count, select **<2>**. To use the backlight after a keypress, select **<3>**. To use the backlight after either a count or a keypress, select **<4>**. After the mode is selected, the gauge displays:

**Backlight Time On:
0 Seconds
Input Time and
Press ENTER**

Using the number keys, enter the time in seconds that the display is to remain backlit. Press the **<ENTER>** key.

The gauge saves the backlight setup and returns to the *Gauge Setup* menu. Return to the *Ready* screen by pressing the **<ESC>** key.

NOTE

The gauge also features a hardware adjustment for the display contrast. If the gauge display is difficult to read in bright light, adjust the contrast as described in the *Display Contrast* section on page C–27.

SLEEP MODE/DISPLAY TIMEOUT (SPECIAL KEY)

To conserve power, the Model 3450 provides a *sleep* mode. If a key is not pressed within a set *timeout*, the gauge turns the display off. This is the sleep mode. When the gauge *sleeps*, it does not forget its previous state or lose data. In the sleep mode, the red light beside the display flashes. When the gauge is taking counts, the red light on the right of the display flashes more rapidly until the count is complete.

NOTE

Increasing or disabling the display time out reduces the battery life.

The *display timeout* is the time the gauge waits between keystrokes before it enters sleep mode. The default display timeout is 30 seconds. To change the display timeout, press **<6>** *Display Timeout* at the *Gauge Setup* menu shown on page 3–9.

Set Display Time-Out	
1- 15 Sec	2- 30 Sec
3- 1 Min	4- 5 Min
5- Continuous On	

To select the timeout, use the corresponding number key.

The gauge saves the display time out and returns to the *Gauge Setup* menu. Return to the *Ready* screen by pressing the **<ESC>** key.

BATTERY STATUS (SPECIAL KEY)

The *Battery Status* option displays the status of the charger and the voltage of the NiCad and alkaline batteries. For more information, see the *Battery Status* section on page C–19.

SET UNITS (SPECIAL KEY)

The Model 3450 can display measurement results in either metric (SI) or U.S. units. To set the units, press **<8>** *Set Units* at the *Gauge Setup* menu shown on page 3–9.



The gauge displays the current units on the first line. Select the new units using the corresponding number key.

The gauge displays the new units, then returns to the *Gauge Setup* menu. Return to the *Ready* screen by pressing the **<ESC>** key.

CUSTOMER NAME (SPECIAL KEY)

The Model 3450 can store a customer name or other messages up to 20 characters. To enter a customer name, press **<9>** at the *Gauge Setup* menu shown on page 3–9.

The *Customer Name* option requires the access code shown on page xi. At the gauge prompt, use the number keys to enter the access code.

The gauge displays the current customer name on the second line. To change the customer name, press the **<YES>** key.



To enable the alphabetic keys on the gauge, use the **⟨SHIFT⟩** key. When the alphabetic keys are enabled, the cursor blinks. The **⟨NO⟩** key acts as a character backspace. Enter the new name and press the **⟨ENTER⟩** key.

The gauge stores the new customer name, then returns to the *Gauge Setup* menu.

COUNT TIME

The *count time* defines how long the gauge reads. Longer count times produce better measurement precision. Troxler recommends a count time of one minute for most sample measurements.

To change the count time, press the **⟨TIME⟩** key.

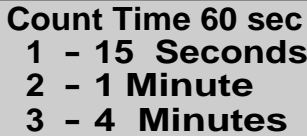

Count Time 60 sec
1 - 15 Seconds
2 - 1 Minute
3 - 4 Minutes

The gauge displays the current count time on the first line and options on subsequent lines. To select the desired count time, press the corresponding number key.

The gauge sets the new count time, then returns to the *Ready* display.

TARGET

Target values include Proctor values, Marshall values, and voidless density values. The *voidless density* is the maximum theoretical density for the test material as obtained in laboratory tests. The gauge uses the Proctor value when taking counts in the soil mode. It uses the Marshall and/or voidless density values in the asphalt and thin layer modes.

The Model 3450 can store up to four Proctor, Marshall, or voidless density target values. The gauge can also store three sets of Marshall and voidless density value pairs. The gauge uses the target values to determine the percent compaction after it has determined the density of the test material.

With the *Target* feature, the operator can enter a new target value, enable a stored target value, or disable a target value. To access the *Target* feature, press the <TARGET> key. The gauge displays the *Target* menu, as shown:

1- PR = x.xxx
2- MA = x.xxx
3- Voidless = x.xxx
4- Voidless/MA Pair

On the first line, the gauge displays the active Proctor value. On the second line, the gauge displays the active Marshall value. The third line shows the active voidless density value.

Proctor, Marshall, and Voidless Density

To edit a Proctor, Marshall, or voidless density value, press the number key that matches the number beside the target value display. For example, to edit the Proctor value, press <1>.

The gauge displays the *Target Value* menu. The *Target Value* menu for the Proctor value is:

Proctor Value:	
1: xxxx	2: xxxx
3: xxxx	4: xxxx
5: New	6: Disable

The *Target Value* menu shows the four stored target values and the *New* and *Disable* options.

ENABLE A DISPLAYED VALUE. To enable a displayed target value, press the number key that matches the number beside the target value on the *Target Value* menu. The gauge will enable the target value and return to the *Target Value* menu. Return to the *Ready* screen by pressing the **<ESC>** key.

STORE A NEW VALUE. To store a new target value, press **<5>** *New* at the *Target Value* menu. At the prompt, use the number keys to enter the target value. Press the **<ENTER>** key.

The gauge displays the value entered and asks if the operator wants to store the value. To store the value, press the **<YES>** key. Pressing the **<NO>** key allows the operator to use the value now without storing it for later use.

If the operator presses the **<YES>** key, the gauge can store the value in one of four *memory cells*. Storing a new value in a cell erases the old value. At the **Select memory cell** prompt, use the number keys to store the value. This will replace any stored values that were previously associated with the memory cell.

The gauge will enable the target value and return to the *Target* menu. Return to the *Ready* screen by pressing the **<ESC>** key.

DISABLE THE TARGET VALUE. To disable the target value, press **<6>** *Disable* at the *Target Value* menu. The gauge will disable the target value and return to the *Target* menu. Return to the *Ready* screen by pressing the **<ESC>** key.

NOTE

The 3450 gauge can be used with the target value disabled. In this case, no percent compaction value will be displayed.

Marshall Value/Voidless Density Pairs

To edit a density pair target, press <4> *New Pair* at the *Target* menu. The gauge displays the *Pairs* menu:



The *Pairs* menu shows the three stored sets of Marshall and voidless density value pairs and the *New Pair* and *Disable* options.

ENABLE A PAIR. To enable a displayed Marshall value/voidless density pair, press the number key that corresponds to the desired pair on the *Pairs* menu. The gauge enables the pair and returns to the *Target* menu. Return to the *Ready* screen by pressing the <ESC> key.

STORE A NEW PAIR. To store a new target value, press <4> *New Pair* at the *Pairs* menu. The gauge displays:

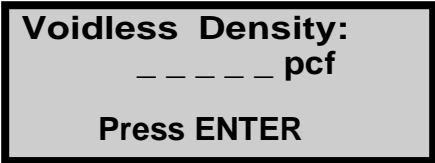

Use the number keys to enter the voidless density value. Press the <ENTER> key. The gauge displays:



Use the number keys to enter the Marshall value. Press the <ENTER> key.

The gauge displays the voidless density and Marshall values entered, and asks if the operator wants to store the pair. To store the pair, press **<YES>**. Pressing **<NO>** allows the operator to use the values without storing them for later use.

The gauge can store the pair in one of three memory cells. Storing a new pair in a cell erases the old pair. At the **Select memory cell** prompt, use the number key that corresponds to the desired cell to store the pair.

The gauge enables the pair and returns to the *Target Value* menu. Return to the *Ready* screen by pressing the **<ESC>** key.

DISABLE A PAIR. To disable the Marshall value/voidless density pair, press **<5>** *Disable* at the *Pairs* menu. The gauge disables the pair and returns to the *Target* menu. Return to the *Ready* screen by pressing the **<ESC>** key.

MEASUREMENT MODE

The Model 3450 provides three measurement modes (*Soil*, *Asphalt*, and *Thin Layer*) for precise readings on base and thin layer asphalt, concrete, soil, soil-stone aggregate, and similar materials. Before taking a measurement, select the appropriate measurement mode.

To select a measurement mode, press the **<MODE>** key. The gauge displays:

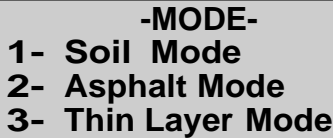

-MODE-
1- Soil Mode
2- Asphalt Mode
3- Thin Layer Mode

Use the *Soil* mode when measuring soil or a soil-stone aggregate. Use *Asphalt* mode when measuring concrete or asphalt layers of 4 inches or greater. Select the *Thin Layer* mode when measuring thin-layer asphalt of less than 4 inches. Use the number keys to select the mode.

If the *Thin Layer* mode is selected, the gauge prompts for the overlay thickness. Use the number keys to enter the overlay thickness, and press the **<ENTER>** key.

The gauge enables the selected measurement mode and returns to the *Ready* display.

QA SAMPLING (SPECIAL KEY)

The *QA Sampling* function generates random sample locations. Using random sample locations helps ensure fair and representative quality assurance sampling. The gauge bases the QA sample locations on the operator input for *average sample separation* and total number of samples. The average sample separation is the average distance between QA samples.

For example, if the QA protocol requires a sample every 500 feet on a 2000-foot strip, the samples will be randomly separated and the number of samples will be four. The first location will be a randomly selected value between 1 and 500; the second between 501 and 1000; the third between 1001 and 1500; and the fourth between 1501 and 2000.

After the gauge generates the sample locations, the operator can view or print the locations as a guide for QA testing.

To access the *QA Sampling* menu, press the **<SPECIAL>** key. At the *Special* functions menu, access the *Special Operation* menu by pressing **(1)**. At the *Special Operation* menu, press **(5)** *QA Sampling* (use the arrow keys to scroll to choose *QA Sampling*). The gauge displays the *QA Sampling* menu:

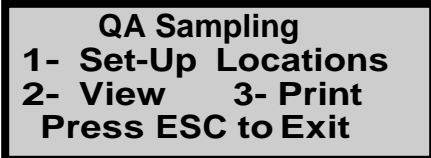
A rectangular screen with a black border and a light gray background. The text is centered and reads: "QA Sampling", "1- Set-Up Locations", "2- View", "3- Print", and "Press ESC to Exit".

QA Sampling
1- Set-Up Locations
2- View 3- Print
Press ESC to Exit

Use the corresponding number key to select a menu option.

Set Up QA Sample Locations

To set up the QA sampling mode, press **(1)** *Set-Up Locations* at the *QA Sampling* menu.

QA Sampling
Enter Average Sample
Separation: xxxx
Press ENTER

Enter the average sample separation, up to 1000 (QA test strip length divided by the number of samples to be taken). Then press the **(ENTER)** key.

QA Sampling
Enter Total Number
of Samples: xxx
Press ENTER

Enter the total number of samples, up to 100, using the number keys. Then press the **(ENTER)** key.

The gauge stores the setup and returns to the *QA Sampling* menu. Return to the *Ready* screen by pressing the **(ESC)** key.

View QA Sample Locations

To view the current QA sample positions, press **(2)** *View* at the *QA Sampling* menu.

QA Sampling	
Sample#	Position
#1	xxxx
#2	xxxx

To scroll through the current QA sample positions, use the arrow keys. To return to the *Ready* screen, press the **(ESC)** key.

Print QA Sample Locations

For details on printer setup, see page 3–13. To print the current QA sample positions, press **<3>** at the *QA Sampling* menu. The gauge displays **Printing Positions**. After printing the QA sample locations, the gauge returns to the *QA Sampling* menu. Return to the *Ready* screen by pressing the **<ESC>** key.

NUMBER AVERAGES (SPECIAL KEY)

The *Number Averages* function allows averaging of up to nine readings from a single test location when testing thin layer asphalt. This function is used only when the gauge is measuring in thin layer mode. When the gauge is using this function, it automatically prompts for repositioning of the gauge from a test location and begins another measurement. After all measurements have been completed, the gauge calculates the average density of the test material. When taking counts on thin layer asphalt, Troxler recommends averaging four one-minute readings (see the *Thin Layer Mode* section on page 4–14).

To access the *Number Averages* function, press the **<SPECIAL>** key. At the *Special* functions menu, access the *Special Operations* menu by pressing **<1>**. At the *Special Operation* menu, press **<3>** *Number Averages*. The gauge displays:

**Input Number Of Thin
Lift Averages:
—
Then Press ENTER**

Enter the desired number of readings (1 through 9) for the gauge to average. Press the **<ENTER>** key. The gauge sets the number of readings and returns to the *Ready* screen.

% AIR VOIDS (SPECIAL KEY)

The gauge uses the specific gravity of the material to calculate percent air voids and void ratio in soil mode only. The *% Air Voids* feature allows the operator to enter the specific gravity of a material and disable or enable the percent air voids display.

NOTE

To display percent air voids in asphalt or thin layer mode, enter a voidless density target value (see the *Target* section that begins on page 3–19).

To access the *% Air Voids* feature, press the **<SPECIAL>** key. At the *Special* functions menu, access special operations by pressing **<1>**. At the *Special Operation* menu, access percent air voids by pressing **<4>**. The gauge displays the *% Air Voids* menu:

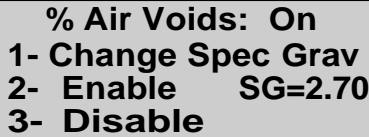

```
% Air Voids: On
1- Change Spec Grav
2- Enable      SG=2.70
3- Disable
```

The current specific gravity (default 2.70) is shown on the third line.

To either enable an existing specific gravity or enter a new one, press **<2>** at the *% Air Voids* menu. The gauge prompts the operator for a new specific gravity. If the displayed specific gravity is acceptable, press the **<ENTER>** key. To change the specific gravity, use the numeric keys to do so, then press the **<ENTER>** key. In either case, the gauge enables the percent air voids display and returns to the *Ready* screen.

To disable the percent air voids display, press **<3>** at the *% Air Voids* menu. The gauge disables the percent air voids display and returns to the *Ready* screen.

NOTES

CHAPTER 4

USING THE GAUGE

This chapter explains the basic use of the Troxler Model 3450 RoadReader Plus. Basic use includes taking the daily standard count, preparing measurement sites, setting the measurement mode, and taking measurements.

CONTENTS

Taking a Standard Count	4-2
Preparing a Test Site	4-6
Soil Site	4-6
Asphalt Site	4-8
Taking Measurements	4-9
Soil Mode	4-10
Asphalt Mode	4-12
Thin Layer Mode	4-14

TAKING A STANDARD COUNT

To adjust readings for source decay (see Appendix A) and natural background radiation, take a daily *standard count*. A four-minute daily standard count helps ensure the highest measurement accuracy.

Locate the reference standard block shipped with the gauge. Always take standard counts using the reference standard block.

Choose a standard count site. The standard count site should be:

- ◆ Dry and flat
- ◆ At least 3 meters (10 ft) from any large vertical surface
- ◆ At least 10 meters (33 ft) from any other radioactive source
- ◆ On asphalt, concrete, or compacted soil at least 10 centimeters (4 in.) thick

Turn the gauge on. At the *Ready* display, press the **<STANDARD>** key. The gauge displays the last standard counts for density (DS) and moisture (MS).

DS = xxxx xxxx
MS = xxxx
1- Take new count
2- View counts

To take a new standard count, press **<1>**. To view the last four standard counts, press **<2>** and scroll through the counts by pressing the **<ENTER>** key.

When taking a new standard count, the gauge displays:

Put Rod In STD Pos
Place Gauge On
Standard Block
Press ENTER

Place the reference standard block on the standard count site. As shown in Figure 4–1, place the gauge on the reference standard block, with the right side (keypad side) of the gauge against the metal butt plate. Ensure that the source rod is in the standard (SAFE) position and is firmly seated by gently tapping the handle of the source rod.

Begin the standard count by pressing the **<ENTER>** key. After taking the standard count, the gauge displays the results:

DS1=xxxx	x.x%PASS
DS2=xxxx	x.x%PASS
MS=xxxx	x.x%PASS
Use New Standard?	

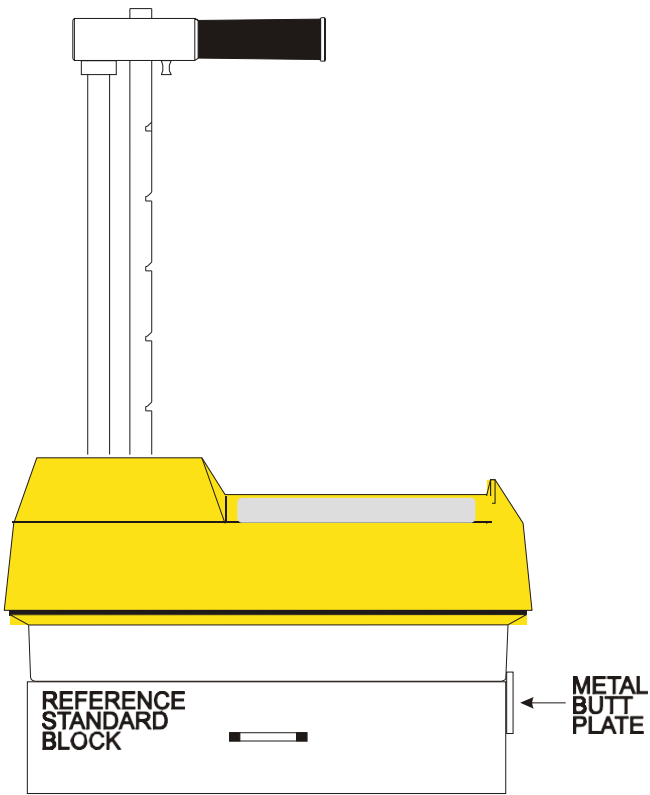

Figure 4–1. Standard Count Position

Troxler recommends that the operator keep a daily log of the moisture and density standard counts (see Appendix E). To verify gauge stability, compare the daily standard count to a reliable reference as follows:

- ◆ During the first four days of operation of a new or recalibrated gauge, compare the daily standard count to the factory-calibrated values.
- ◆ After the first four days of operation (or after taking four standard counts), compare the daily standard count to the average of the last four counts. Acceptable standard count limits are:

$\pm 1.3\%$ each day for DS1 and DS2 (density standards) and
 $\pm 1\%$ each day for MS (moisture standard).

- ▶ If the standard count *passes*, record the standard counts, then press the **<YES>** key. The gauge displays:

**Depth Calibration
Set Rod To BS.

And Press ENTER**

The gauge calibrates the index rod depth strip and returns to the *Ready* display.

- ▶ If the standard count *fails* and it has been *more than* a month since the last standard count, then accept the standard count by pressing the **<YES>** key. At the **Do You Want To Erase Last Four Standard Counts?** prompt, press the **<YES>** key. The gauge displays:

**Depth Calibration
Set Rod To BS.

And Press ENTER**

Follow the displayed instructions, and take four additional standard counts. The last of these counts will be compared to the previous four, and the standard counts should pass. If not, repeat the procedure. If it still fails, perform a stat test (see page C-3) and a drift test (see page C-5), then contact your Troxler representative.

- ▶ If the standard count *fails* and it has been *less than* a month since the last standard count, but the count was performed correctly and the failure is less than 5%, press the **<YES>** key. If the failure is more than 5%, press the **<NO>** key. Ensure that the gauge is properly positioned on the reference standard block (Figure 4-1). Verify that the standard count site meets the criteria listed on page 4-2. Take another standard count and accept it if it fails by less than 5%. If the standard count fails four times, perform a stat test (see page C-3) and a drift test (see page C-5), then contact your Troxler representative.

After the standard count passes, the operator can take measurements with the gauge. When not taking readings, always keep the source rod in the **SAFE** position. For added user safety, the source rod automatically retracts to the **SAFE** position when the gauge is lifted using the handle.

PREPARING A TEST SITE

To ensure measurement accuracy, properly prepare the test site before taking gauge measurements. This section describes how to prepare test sites properly for soil and asphalt measurements.

SOIL SITE

- ✓ Locate a smooth site on the soil free from any large holes, cracks, or debris.
- ✓ If necessary, smooth the surface by moving the scraper plate in a back and forth motion.
- ✓ Fill any voids or depressions with fine sand. Strike off any excess fill.
- ✓ Place the scraper plate back on the surface and press down slightly to level the surface.
- ✓ For direct transmission measurements:
 - ✓ Put the drill rod through the extraction tool and then through one of the guides on the scraper plate (Figure 4–2).
 - ✓ Wear safety glasses and a radiation dosimeter.
 - ✓ Place the drill rod assembly on the test site.
 - ✓ Step on the scraper plate.
 - ✓ Hammer the drill rod at least fifty millimeters (2 in.) deeper than the desired test depth. The drill rod increments include the additional depth.
- ✓ Mark the test area before removing the drill rod to ensure the gauge is placed over the same area as the scraper plate (Figure 4–3).

CAUTION

Under no circumstances should the source rod of the gauge be used to drill holes.

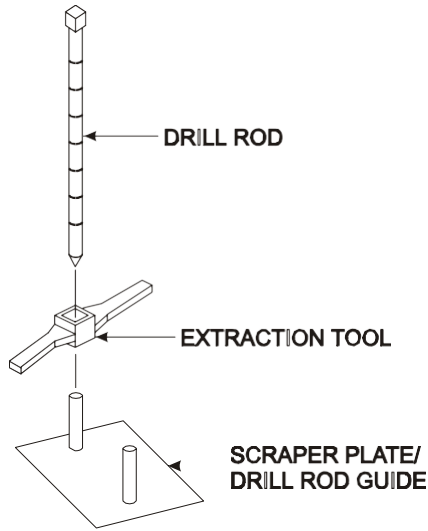

Figure 4–2. Drill Rod Assembly

- ✓ Remove the drill rod by pulling straight up and twisting the extraction tool. *Do not loosen the drill rod by tapping from side to side with a hammer.* Also, do not rock the extraction tool from side to side. This will distort the hole or cause loose material to fall into the hole.
- ✓ Carefully pick up the scraper plate.

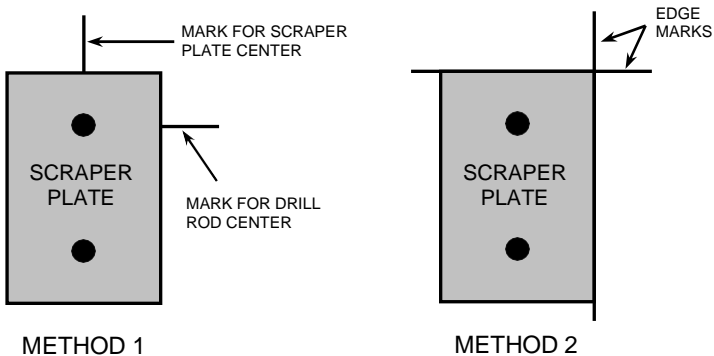

Figure 4–3. Marking the Test Area

ASPHALT SITE

This also applies to hardened concrete sites and soil.

NOTE

These directions also apply to taking a backscatter measurement on soil.

- ✓ Locate a smooth site on the asphalt.
- ✓ Fill the voids on open mixes with sand or cement. **The gauge base must rest on the asphalt, not the fill material!**
- ✓ Ensure that the gauge does not rock. To ensure accurate readings, the gauge base must be completely in contact with the test material. If the gauge rocks, then find a more suitable test site. If taking a measurement around a core, the gauge may be moved a few inches away from the core to level it.

TAKING MEASUREMENTS



NOTE

When not taking readings, always keep the source rod in the SAFE (shielded) position. For added user safety, the source rod automatically retracts to the SAFE position when the gauge is lifted by the handle.

If you do not hear a *click* when the gauge is raised to the **SAFE** position, look at the bottom of the gauge to verify that the tungsten sliding block is completely closed. If the gauge base opening is not completely closed by the sliding block, the sliding block and fixed tungsten block may require cleaning. Refer to page A-11 for cleaning instructions.



WARNING

Do not store or transport the gauge unless the sliding block is completely closed. Increased radiation levels may cause excessive personnel radiation exposure and may violate transportation regulations.

The *Current Status* feature (see page 3–9) allows the operator to view the current gauge status. This feature provides a quick overview of all enabled functions (mode of operation, enabled offsets, displayed units, etc.). Check the gauge's current status before taking measurements. To change any of the *Current Status* parameters, refer to Chapter 3.

Remember to take a standard count each day the gauge is to be used (see page 4–2).

For more information on storing measured data, see the *Storing Data* section on page 5–10.

If the gauge enters the sleep mode while taking counts, the red light will flash more rapidly until the count is complete. To restore the display, press any key.

SOIL MODE

To measure the moisture and density of soil, soil-stone aggregate, and similar materials, follow the steps below:

- ✓ Select the *Soil* mode (see page 3–23).
- ✓ If desired, enter, change, or enable the Proctor value (see page 3–19).
- ✓ Prepare the test site as described on page 4–6.
- ✓ Place the gauge on the test area.
- ✓ Insert the source rod into the hole made by the drill rod or source rod adapter. *Use care when inserting the source rod. Try not to disturb the soil around the hole.*
- ✓ Lower the source rod to the measurement depth. Release the trigger. Gently tap down on the handle over the source rod to lock the source rod into position. You should hear a *click* when the source rod locks into position.
- ✓ Gently slide the gauge to the right (towards the keypad) so the source rod makes contact with the wall of the hole.
- ✓ Press the **<START>** key.
 - ▶ In the *Manual* depth mode (see page 3–14), the gauge will prompt for the source rod depth. Enter the source rod depth using the number keys. For example, with the source rod in the backscatter position, press **<0>**. Then press **<ENTER>**.
 - ▶ In the *Automatic* depth mode, the gauge software reads the depth strip on the source rod to determine the source rod depth.
 - ▶ Note that the Proctor value is based on soil particles 3/8 inches or less in diameter (or those passing a #4 sieve). If an unusual reading is obtained and oversize particles are suspected, rotate the gauge 90°. Use the same drill hole to take a second reading.

NOTE

Prior to countdown, the gauge may display **Please Wait** for five seconds. This occurs if the baseboard electronics require warmup prior to starting the measurement.

- ✓ The gauge will display the time remaining while taking a measurement.
- ✓ After the count time, the gauge displays the measurement results.

NOTE

This is one of three screens that may appear, depending on the previous selections.

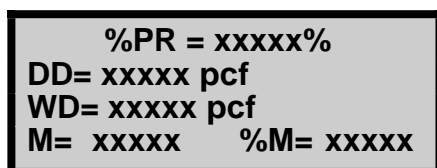

```
%PR = xxxxx%  
DD= xxxxx pcf  
WD= xxxxx pcf  
M= xxxxx    %M= xxxxx
```

where: %*PR* = percent Proctor
 DD = dry density
 WD = wet density
 M = moisture
 %*M* = percent moisture

If a project is enabled (see the *Handling Project Data* section on page 5–5), press the **<STORE>** key to store the measurements. To scroll through the results, use the arrow keys. Return to the *Ready* screen by pressing the **<ESC>** key, or press the **<START>** key to make another measurement.

- ✓ Lift the gauge from the test site by the source rod handle. This returns the source rod to the **SAFE** position. When not taking readings, always keep the source rod in the **SAFE** position.

ASPHALT MODE

To measure the density of asphalt (and hardened concrete of 4 inches or more) follow the steps below:

- ✓ Select the *Asphalt* mode (see page 3–23).
- ✓ If desired, enter or enable the Marshall value, voidless density value, or Marshall value/voidless density pair (see page 3–19).
- ✓ Prepare the test site as described on page 4–8.
- ✓ Place the gauge on the test area.
- ✓ Lower the source rod to the backscatter position. Release the trigger. Gently tap on the handle over the source rod to lock the source rod into position. You should hear a *click* when the source rod locks into position.
- ✓ Press the **<START>** key.
- ▶ In the *Manual* depth mode (see page 3–14), the gauge will prompt for the source rod depth. Enter the source rod depth using the number keys. For example, with the source rod in the backscatter position, press **<0>**. Then, press **<ENTER>**.
- ▶ In the *Automatic* depth mode, the gauge software reads the depth strip on the source rod to determine the source rod depth.
- ✓ The gauge will display the time remaining while taking a measurement.

NOTE

Prior to countdown, the gauge may display *Please Wait* for five seconds. This occurs if the baseboard electronics require warmup prior to starting the measurement.

- ✓ After the count time, the gauge displays the measurement results.

%MA = xxxxx %
WD = xxxxx pcf
%VOIDS = xxxxx

where: **%MA** = percent Marshall

WD = wet density

$$\%VOIDS = 100 \times \frac{1 - WD}{VOIDLESS}$$

(displayed only when enabled)

If a project is enabled (see the *Handling Project Data* section on page 5–5), press the **(STORE)** key to store the measurement(s). To scroll through the results, use the arrow keys. Return to the *Ready* screen by pressing the **(ESC)** key, or press the **(START)** key to make another measurement.

- ✓ Lift the gauge from the test site using the source rod handle. This returns the source rod to the **SAFE** position. When not taking readings, always keep the source rod in the **SAFE** position.

THIN LAYER MODE

To measure the density of thin layer asphalt, follow the steps below.

When taking counts after a core has been removed, Troxler recommends averaging four one-minute readings taken around the core site, as shown in Figure 4-4. If no core has been removed, place the gauge over the test site, as shown in Figure 4-5.

- ✓ Select the *Thin Layer* mode (see page 3-23).
- ✓ When the *Thin Layer* mode is selected, the gauge prompts the operator for the overlay thickness (see page 3-23). To enter a new overlay thickness, use the numeric keys and press the **<ENTER>** key when finished.
- ✓ If desired, enter or enable the Marshall value, voidless density value, or Marshall value/voidless density pair (see page 3-19).

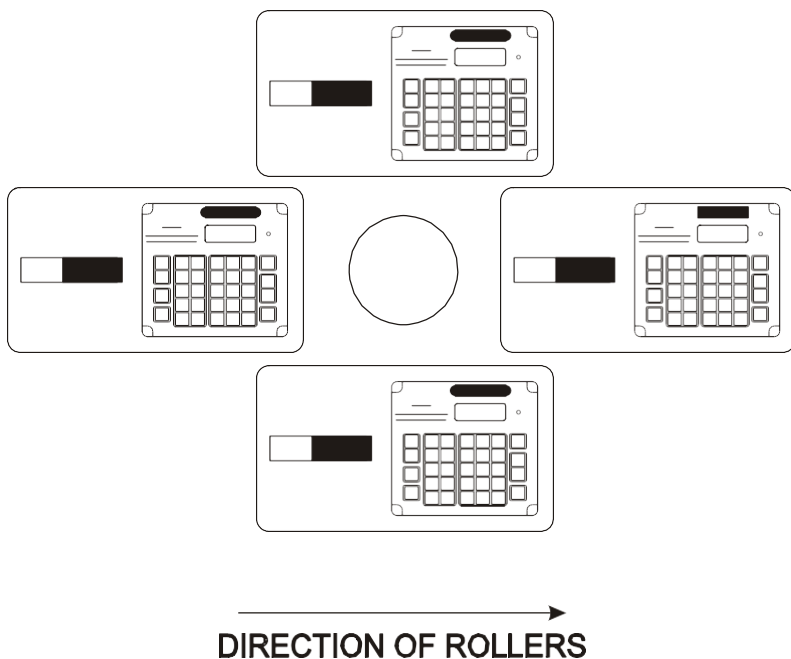

*Figure 4-4. Gauge Positioned Around a Core Site
(If Core Has Been Removed)*

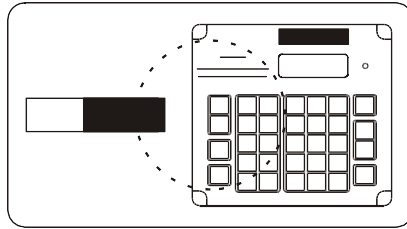

Figure 4–5. Gauge Positioned Over Designated Test Site

- ✓ Prepare the test site as described on page 4–8 for a backscatter measurement.
- ✓ Place the gauge on the test area.
- ✓ Press the **⟨START⟩** key.

**Ready For
Count 1 of x
Place in BS Then
Press START**

- ✓ Lower the source rod to the backscatter position. Release the trigger. Gently tap down on the handle over the source rod to lock the source into position. You should hear a *click* when the source rod locks into position.
- ✓ Press the **⟨START⟩** key again when prompted.
- ✓ The gauge displays a countdown.

NOTE

Prior to countdown, the gauge may display *Please Wait* for five seconds. This occurs if the baseboard electronics require warmup prior to starting the measurement.

- ✓ After the count time, the gauge displays the density (D) and the density counts. To continue, press the **⟨ENTER⟩** key.
- ✓ Reposition the gauge and repeat the above procedure for each count.

- ✓ After taking all the counts, the gauge displays the measurement results.

**%MA = xxxxx %
D = xxxxx pcf
%VOIDS = xxxxx**

where: %MA = percent Marshall

D = density

$$\%VOIDS = 100 \times \frac{1 - D}{VOIDLESS}$$

(displayed only when enabled)

Press the **<STORE>** key to store the measurement. To scroll through the results, use the arrow keys. Return to the *Ready* screen by pressing the **<ESC>** key or press the **<START>** key to take a measurement.

- ✓ Lift the gauge from the test site by the source rod handle. This returns the source rod to the **SAFE** (shielded) position. When not taking readings, always keep the source rod in the **SAFE** position. If you do not hear a *click* when the gauge is raised to the **SAFE** position, look at the bottom of the gauge to verify that the tungsten sliding block is completely closed. If the gauge base opening is not completely closed by the sliding block, the sliding block may require cleaning. Refer to page A-11 for cleaning instructions.



WARNING

Do not store or transport the gauge unless the sliding block is completely closed. Increased radiation levels may cause excessive personnel radiation exposure and may violate transportation regulations.

CHAPTER 5

PROJECT DATA

The Troxler Model 3450 RoadReader Plus allows unique project numbers to be entered into the gauge memory. Subsequent measurements can then be stored under this project number. This chapter describes how to handle project data.

CONTENTS

Separating the Control Unit	5-2
Handling Project Data.....	5-5
Select a Project	5-5
Create a Project	5-6
View Data.....	5-7
Print/Upload Data.....	5-7
Erase Projects	5-9
Recover Erase.....	5-9
Storing Data.....	5-10
Store Data.....	5-10
Edit Project Notes.....	5-11
Full Store.....	5-12

SEPARATING THE CONTROL UNIT



CAUTION

– EUROPEAN COUNTRIES –

Do not separate the control unit from the base. Doing so will result in non-compliance with EMC directive. Call your Troxler representative for additional information.

The control unit of the Model 3450 can be separated easily from the gauge. This enables the user to perform gauge setup, review data or status information, and upload or print projects while the nuclear sources are safely stored elsewhere.

The control unit is located on the top of the gauge and includes the keypad and the display. Before removing the control unit, turn the gauge off and disconnect the charger from the rear of the gauge.

CAUTION

Turn the gauge off before disconnecting the control unit. Unexpected operation or board failure may result if the control unit is disconnected while turned on.

NOTE

When working with multiple gauges, note which control unit goes to which gauge. Because gauge calibration constants are stored in the control unit, each control unit must be returned to the gauge from which it was removed.

Remove the control unit by loosening the four screws located in the corners of the keypad. Lift the control unit and place it to the right side of the gauge. Disconnect the ribbon cable where it enters the left side of the control unit by pushing out on the two small latches at the baseboard connector. On recent gauge revisions, the cable is shielded and is secured to the control unit by a flat metal bracket. Using a small Phillips screwdriver, remove the two screws that hold the bracket.

Place the gauge base in a secure location where liquid and dirt cannot enter the gauge (which could damage the baseboard assembly in the bottom of the gauge). The gauge NiCad batteries can be charged with the control unit detached.

The control unit can now be operated independently of the gauge. The control unit is fully functional except that it cannot take a measurement, and cannot read the temperature sensor or perform diagnostics on the baseboard assembly.

The 9-pin serial connector on the side of the control unit can be used to transfer data from the control unit in the same way that the serial connector on the rear of the gauge is used. Take care not to touch or damage the baseboard connector on the side of the control unit as damage to the electronics could result. Also, the control unit should only be removed when the gauge is inside (not outdoors) so the control unit does not become wet or dirty while separated from the gauge.

Before returning the control unit to the gauge base, turn off the control unit and disconnect the charger from the gauge.

CAUTION

Turn the gauge off before reconnecting the control unit. Unexpected operation or board failure may result if the control unit is connected while turned on.

To return the control unit to the gauge, reattach the baseboard connector to the control unit, taking care to align the connector properly. When properly aligned, the connectors should slide together easily without forcing. Push the connector in until the latches on each side click into the locked position. On gauges equipped with a shielded ribbon cable, secure the cable using the flat metal bracket. **Ensure that the shielding of the cable is gripped securely beneath the metal bracket.** Replace the two Phillips screws and tighten.

Gently place the control unit inside the gauge and tighten the four screws in the corners of the keypad. Turn the gauge on. If the gauge displays **Baseboard Not Connected**, then the ribbon cable is not connected properly. Check between the baseboard and the control unit connector again.

If the gauge displays **Incorrect Baseboard ID**, then the control unit is connected to the wrong gauge. The calibration constants for a gauge are stored in its control unit; therefore, the control unit must be returned to the gauge from which it was removed. To ensure that this occurs, the control unit checks an electronic ID on the base. If this error is displayed, return the control unit to the correct gauge.

HANDLING PROJECT DATA

The Model 3450 can store up to 1000 readings. The gauge stores the readings under project names, with up to 620 readings per project. Storing additional project data such as notes will reduce the maximum number of stored readings.

The *Project* and *Store* functions allow handling of project data. The keys for these two functions are located conveniently next to each other on the keypad. Measurement results are stored in files (gauge memory locations) called projects (named by the operator). The *Project* function allows the operator to create a new project, view project data, select a project (make an existing project active so that additional data may be added to it), print the data stored in the project, or erase projects. The *Store* function allows the operator to store measurement results and other test-identifying information in a selected project.

To access the *Project* function, press the **<PROJECT>** key. The gauge displays the *Project* menu with the current project on the first line.

PR#: Your Project	
1- Select Project	
2- New	4- Print
3- View	5- Erase

The following text provides details on the *Project* function.

SELECT A PROJECT

The gauge displays the current project on the first line of the *Project* menu. Use the arrow keys to scroll through the project names. When the gauge displays the desired project, press **<1>**.

The gauge enables the selected project name and returns to the *Ready* screen.

CREATE A PROJECT

To create a new project, press **<2>** at the *Project* menu shown on the previous page.

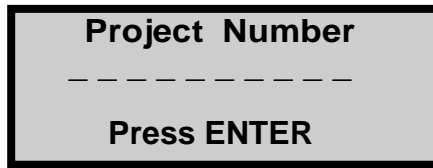

Enter a project name or number at this screen. By default, the number keys are enabled. To use the alphabetic keys, press the **<SHIFT>** key. When the alphabetic keys are enabled, the cursor blinks. The **<NO>** key acts as a character backspace if corrections must be made.

Enter a project name (up to ten characters) using the gauge keypad. To clear an entry, press the **<CE>** key. After the project name is complete, press the **<ENTER>** key.

The gauge prompts for a project ID number, as shown below. The project ID number can be any alternate project identification. For example, the operator could enter the U.S. Federal Highway Administration (FHWA) project number.

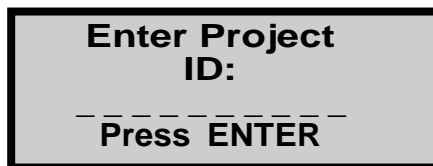

Enter the project ID number (up to sixteen characters) using the gauge keypad. To clear an entry, press the **<CE>** key. After the project ID number is complete, press the **<ENTER>** key.

To enable the new project, press the **<YES>** key. The gauge enables the new project and returns to the *Ready* screen. The new project name will appear on the last line of the *Ready* screen as the active project.

VIEW DATA

The Model 3450 offers two methods of viewing data. The operator can view either the last measurement results, or any project data, including project notes.

To view the last measurement results, press the **<RECALL>** key. Use the arrow keys to scroll through the displays. Return to the *Ready* screen by pressing the **<ESC>** key.

To view any project data, press the **<PROJECT>** key. As shown on page 5–5, the gauge displays the current project on the first line of the *Project* menu. Use the arrow keys to scroll through the project names. When the gauge displays the desired project number, press **<3>**. The gauge displays:

#: Your Project	
ID: xxxxx	
Station: x	
mm/dd/yyyy	HH:MM am

The gauge displays the station number on the third line. To scroll through the station numbers, press **<↑>**. To scroll through the project data for the displayed station number, press **<↓>**. Return to the *Ready* screen by pressing the **<ESC>** key.

PRINT/UPLOAD DATA

The *Print* option within the *Project* menu allows the operator to print (or upload) project data stored in the gauge. To print stat test or drift test data, see Appendix C.

Appendix H provides instructions on using the HyperTerminal program in current versions of Microsoft→Windows→to print (upload) data to a computer.

For details on setting up the gauge software for printing, see the *Printer (Special Key)* section on page 3–13.

To connect the gauge to a printer or computer, remove the cover from the 9-pin serial port on the back of the gauge. Connect a serial printer cable to the gauge serial port. Connect the serial printer cable to the printer (or computer) serial port.

At the *Project* menu shown on page 5–5, press **<4>**. The gauge displays the *Print Project* menu:

A screenshot of a menu displayed on a gauge. The menu is enclosed in a black rectangular border and has a light gray background. It contains three lines of text: the first line is "#: Your Project", the second line is "1-Print This Project", and the third line is "2-Print All Projects".

#: Your Project
1-Print This Project
2-Print All Projects

From this menu, the gauge can print (or upload) either a single project or all projects.

To print (or upload) a single project, use the arrow keys to scroll through the project names displayed on the first line. When the gauge displays the desired project, press **<1>**. The gauge prints (or uploads) the project and returns to the *Print Project* menu shown above. Press the **<ESC>** key to return to the *Ready* screen.

To print (or upload) all projects, press **<2>** at the *Print Project* menu shown above. The gauge prints (or uploads) all the projects and returns to the *Print Project* menu. Press the **<ESC>** key to return to the *Ready* screen.

ERASE PROJECTS

At the *Project* menu shown on page 5–5, press **<5>**. The gauge displays the *Erase Project* menu:

A screenshot of the 'Erase Project' menu. The text is displayed in a white box with a black border. The text reads: '#: Your Project', '1-Erase This Project', and '2-Erase All Projects'.

#: Your Project
1-Erase This Project
2-Erase All Projects

From this menu, the operator can erase either a single project or all projects.

To erase a single project, use the arrow keys to scroll through the project names displayed on the first line. When the gauge displays the desired project, press **<1>**. At the **Are You Sure . . .** display, press the **<YES>** key. The gauge erases the project and returns to the *Erase Project* menu. Return to the *Ready* screen by pressing the **<ESC>** key.

To erase all projects, press **<2>** at the *Erase Project* menu. At the **Are You Sure . . .** display, press the **<YES>** key. The gauge erases all the projects and returns to the *Ready* screen.

RECOVER ERASE

If project data is erased accidentally, the *Recover Erase* function **may** be able to recover the lost information. There is no guarantee that *Recover Erase* will successfully recover lost data. If **any** data has been stored after the accidental erasure, then a successful recovery is impossible.

To attempt to recover erased project data, press the **<SPECIAL>** key. At the *Special* functions menu, press **<3>** to access the *Memory Function* menu. At the *Memory Function* menu, press **<2>**.

If the gauge can recover the erased project data, it will display the recovery and return to the *Ready* screen.

STORING DATA

The Model 3450 can store up to 1,000 readings. The gauge stores readings under the project name that has been enabled. The gauge can store up to 620 readings per project. The operator can retrieve, print, and upload stored project data. For more information on selecting a project, see page 5–5.

When storing test results, the gauge can also store project notes or information required on FHWA projects. The gauge stores this extra project information with the project data. By default, the gauge allows the operator to enter project notes. To *edit* project notes later, use the *Edit Notes* feature described on the following page.

STORE DATA

After taking a measurement, the operator can store the data in the selected project by pressing the **(STORE)** key when the gauge displays the *Ready* screen. The gauge requests the station number as shown below. It displays the last station number on the third line.

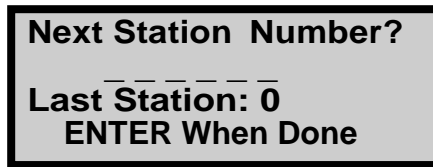

Enter the station number (up to six numbers) and press **(ENTER)**.

The gauge prompts the operator to enter additional project information. Press the **(SHIFT)** key to access the alphabetic characters and enter the information. If *Full Store* mode (page 5–12) is enabled, the 3450 gauge prompts the operator for more in-depth test data. The gauge stores the data with any additional project information under the selected project and returns to the *Ready* screen.

EDIT PROJECT NOTES

Project notes may be edited with the *Edit Notes* function. To edit the notes of the selected project (the project displayed on the last line of the *Ready* screen), press the **<SPECIAL>** key. At the *Special* functions menu, press **<3>** to access the *Memory Function* menu. At the *Memory Function* menu, press **<1>**.

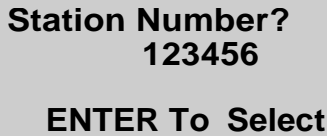

Station Number?
123456

ENTER To Select

The gauge displays the first station number of the selected project on the second line. Use the arrow keys to scroll through the station numbers. When the gauge displays the desired station number, press the **<ENTER>** key to edit the stored notes.

The gauge displays the notes for the selected station. Use the arrow keys to scroll through the notes. Use the alphanumeric keys to edit the project notes. To clear an entry, press the **<CE>** key. The gauge stores the edited notes and returns to the **Station Number?** screen shown above. Press the **<ESC>** key to return to the *Ready* screen.

FULL STORE

The 3450 gauge includes a *Full Store* feature, which provides prompted data entry of measurement conditions after each store. When this feature is enabled, the gauge prompts the operator for information required on FHWA projects. This information is stored in the project with the reading, and can be viewed, printed, or uploaded to a computer with the project data. There are three types of data storage based on the gauge operating mode.

In *Thin Layer* or *Asphalt* mode, the gauge prompts for asphalt-related information such as lift thickness and whether the mix is surface, intermediate, or base.

In *Soil* mode, the operator is prompted to select prompts for *Soil* or *Stone*. The soil prompts include test types such as embankment, subgrade, and backfill. The stone prompts include the test types plain aggregate and cement stone.

The complete listing of *Full Store* prompts is shown in the following sections.

Full Store Prompts. Soil Mode – Soil

- Station Number**
- Relative position**
- 1– Soils**
 - Test for:**
 - 1– Embankments**
 - 2– Pipe Backfill**
 - Enter pipe size**
 - 3– Subgrade**
 - 4– Abut Backfill**
 - 5– Retaining Wall**
 - 6– Rockfill**
- Dir. Lane**
- Elevation above original ground**
- Elevation below finished grade**
- Method of compaction**
 - 1– Sheepsfoot**
 - 2– Tamper**

- 3– Vib Sheepsfoot
- 4– Vibratory Roller
- 5– Static Roller
- Density required

Full Store Prompts, Soil Mode – Stone

- Station Number
- Relative position
- 2– Stone
 - Lift Number
 - Thickness
 - Test for:
 - 1– Plain aggregate
 - 2– Cement stone
- Dir. Lane
- Elevation above original ground
- Elevation below finished grade
- Method of compaction
 - 1– Steel Wheel Stat
 - 2– Steel Wheel Vib
 - 3– Rubber Tire
 - 4– Rubber Tire Vib

Full Store Prompts, Asphalt/Thin Lift Mode

- Station Number
- L/R Of Center Line
- Lift Number
- Thickness
- Test for:
 - 1– Surface Mix
 - 2– Intermediate Mix
 - 3– Base Mix
- Dir. Lane
- Elevation above original ground
- Elevation below finished grade
- Method of compaction
 - 1– Steel Wheel Stat
 - 2– Steel Wheel Vib
 - 3– Rubber Tire
 - 4– 3 Wheel

Enabling Full Store

To enable the *Full Store* feature, press the **⟨SPECIAL⟩** key. At the *Special* functions menu, press **⟨3⟩** to access the *Memory Function* menu. At the *Memory Function* menu, press **⟨3⟩**. The gauge displays the status of the *Full Store* feature on the first line.



To enable the *Full Store* feature, press **⟨1⟩**. To disable the *Full Store* feature, press **⟨2⟩**. The gauge sets the *Full Store* mode and returns to the *Ready* screen.

CHAPTER 6

ADJUSTING MEASUREMENTS

This chapter explains how to adjust gauge readings using *offsets*, and how to create a special calibration.

CONTENTS

Calibration Offset	6-2
Wet Density Offset.....	6-3
Moisture Offset	6-4
Trench Offset.....	6-9
Special Calibration.....	6-11
Density Special Calibration.....	6-11
Thin Layer Special Calibration	6-16

CALIBRATION OFFSET

Troxler calibrates the Model 3450 RoadReader Plus at the factory for use on soils, asphalt, and concrete. The operating range of the gauge is 1100 to 2700 kg/m³ (70 to 170 pcf). If the gauge is to be used on materials outside of this range, the operator can adjust the gauge using an offset. The 3450 gauge provides three offsets: *wet density*, *moisture*, and *trench*.

Perform a *wet density offset* if the test material is outside the range of material composition and/or texture used during factory calibration.

Perform a *moisture offset* if the test material contains hydrogen in forms other than water, or is high in neutron absorbers. Examples of materials rich in hydrogen are cement, gypsum, coal, or lime. The moisture offset for soils containing these materials is a *negative* value. If the material is high in neutron-absorbing material, such as boron, cadmium, or chlorine, then the offset must be a *positive* value.

Perform a *trench offset* before taking measurements inside a trench or close vertical structures. Vertical structures scatter neutrons and gamma photons back to the gauge. This scattering could result in inaccurate moisture and density readings.

NOTE

When turned off, the gauge disables all special calibrations and offsets.

WET DENSITY OFFSET

The wet density offset is the difference between the gauge reading and the actual density. To access the wet density offset functions, press **<OFFSET>** to access the *Offset* menu. Then press **<1>** to access the *Wet Density Offset*.



Wet Density Offset:
xxxx kg/m³
1-Enable 2-Disable
3-Change Offset

The gauge displays the current wet density offset on the second line. To enable the offset, press **<1>**. To disable the offset, press **<2>**.

To enter a new wet density offset, press **<3>**. The gauge prompts for the wet density offset.

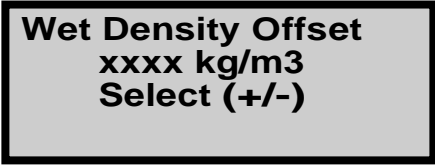

Wet Density Offset
xxxx kg/m³
Select (+/-)

To change the offset, select the offset sign (positive or negative). Enter the wet density offset. Press **<ENTER>**. The gauge enables the new wet density offset and returns to the *Ready* screen.

MOISTURE OFFSET

The moisture offset (k) is determined by comparing the moisture of a laboratory sample with the gauge moisture reading. With the Model 3450, the operator can either allow the gauge to derive the moisture offset or enter the moisture offset manually. To select a stored moisture offset or to allow the gauge to derive the moisture offset, see below. To manually enter the moisture offset, refer to page 6–8.

Select a Stored Moisture Offset

To select a moisture offset already stored in the gauge, access the *Offset* menu by pressing **<OFFSET>**. Access the *Moisture Offset* menu by pressing **<2>**. Select the *Change Offset* menu by pressing **<3>**.

Moisture Offset
1- Stored Offset
2- Gauge Derived
3- Keypad Entry

Press **<1>** *Stored Offset*. The gauge displays the stored moisture offsets. Use the number keys to select a moisture offset. The gauge enables the moisture offset and returns to the *Ready* screen.

Gauge-Derived Moisture Offset

To allow the gauge to derive the moisture offset, the operator must take readings with the gauge and then enter the true moisture derived by an oven dry or similar method. The Model 3450 can store one partial offset. A partial offset allows the operator to take readings and enter the true moisture at different times.

NOTE

When using destructive methods such as drilling cores or sample removal for true moisture measurement, take gauge readings before removing samples.

Access the *Offset* menu by pressing the **<OFFSET>** key. Access the *Moisture Offset* menu by pressing **<2> Moisture**. To change the offset, press **<3> Change Offset**.

Moisture Offset
1- Stored Offset
2- Gauge Derived
3- Keypad Entry

Press **<2> Gauge Derived**.

**Gauge Derived
Moisture Offset**
1- Measure Moisture
2- Input True Moist

If the operator saved a partial offset earlier, then the gauge will display a *P* beside the option entered before. To take readings for the offset, press **<1>** and refer to *Measuring the Moisture* below. To enter the true moisture, press **<2>** and refer to *Entering True Moisture* on page 6–7.

MEASURING THE MOISTURE. To measure the moisture, press **<1>** *Measure Moisture*.

**Place Gauge On
Surface To Be Tested
Press START For 4
One-Minute Counts**

Prepare the test site as described on page 4–6. Place the gauge on the test site and position the source rod in the measurement position. Press the **<START>** key.

The gauge displays the progress of the measurements. After taking each reading, the gauge displays the results. To continue to the next reading, press the **<START>** key. After the last reading, press the **<ENTER>** key. If the true moisture has not yet been stored, the gauge displays:

**Moisture Offset
1- Store Partial
Moisture Offset
2- Input True Moist**

To enter the true moisture later, create a partial offset by pressing **<1>**. To enter the true moisture now, press **<2>** and follow the gauge prompts to complete the offset.

ENTERING TRUE MOISTURE. Under normal circumstances, the true moisture will be entered at a time later than the measured moisture. If measured moisture has been stored as a partial offset, return to the *Moisture Offset* menu found directly above and press **<2>**.

The gauge requests the true moisture:

Input True Moisture
xxxxx %
ENTER When Done

COMPLETING GAUGE-DERIVED MOISTURE OFFSET.

After storing measured moisture and true moisture, the gauge will display the values and resulting offset value, k (see formula on the following page). The gauge offers four memory locations to store the k value. Select the desired memory location to save the value.

Edit a Partial Moisture Offset

If the operator saved a partial offset, then the gauge will display a P beside the option entered before. Select the value to be completed.

If a value already entered is selected, then the gauge prompts the operator to overwrite. To overwrite the partial offset, press the **<YES>** key. To use the stored partial offset, press the **<NO>** key and select the other value.

To take measurements, see page 6–6. To enter the true moisture, see the description above.

Enter Moisture Offset (Keypad Entry)

Use standard laboratory methods (for example, oven drying, and so on) to determine the true moisture content of a sample taken at the measurement site ($\%M_{LAB}$).

Take a gauge reading at the site. Record the reading ($\%M_{GAUGE}$). Take multiple samples and measurements, and calculate the average moisture of the samples. Use this average value for the offset factor calibration.

Calculate the offset factor (k), using the following formula:

$$k = \frac{\%M_{LAB} - \%M_{GAUGE}}{100 + \%M_{GAUGE}} \times 1000$$

Access the *Offset* menu by pressing the **<OFFSET>** key. Access the *Moisture Offset* menu by pressing **<2>**.

Moisture Offset
K=xxxx
1-Enable 2-Disable
3-Change Offset

Press **<3>** *Change Offset*, then **<3>** *Keypad Entry*. Follow the gauge prompts to enter the true moisture and gauge moisture reading. The gauge displays the moisture offset (k) and prompts the operator to save. To save the offset, press the **<YES>** key, then select one of the four memory cell locations.

TRENCH OFFSET

To use the Model 3450 in a trench or within 0.6 m (2 ft) of a large vertical surface, first perform a *trench offset*. The trench offset adjusts all moisture and density measurements from backscatter to 4 inches. For direct transmission measurements over 4 inches deep, only the moisture measurement needs to be adjusted. In the displays shown below, *TMO* refers to *trench moisture offset*; *TDO* refers to *trench density offset* values (one for each set of detectors).

Access the *Offset* menu by pressing the **<OFFSET>** key. Access the *Trench Offset* menu by pressing **<3>**.

**Trench: TMO = xxxx
TDO = xxxx xxxx
1-Enable 2-Disable
3-Change Offset**

The gauge displays the current trench offset values. To enable the offset, press **<1>**. To disable the offset, press **<2>**.

To create a new trench offset, press **<3>**. The gauge displays:

**Set Rod to STD Pos
Press START For
1 Minute STD Count
In Trench**

Select a position inside the trench and the same distance from the wall as the test measurements. Place the gauge on the standard block in this position. Press the **<START>** key.

The gauge displays the progress of the standard count operation.
After the standard count, the gauge displays:

New Trench Offset
TMO = xxxx
TDO = xxxx xxxx
Want To Accept?

To enable the new trench offset, press the **<YES>** key. To create another trench offset, press the **<NO>** key and repeat.

SPECIAL CALIBRATION

The *Special Calibration* features allow the operator to recalibrate Model 3450 soil and thin layer readings. Special calibrations are specific for the test material and measurement depth. The gauge can store four density special calibrations and four thin-layer special calibrations.

NOTE

When turned off, the gauge disables all special calibrations and offsets.

Before performing a special calibration:

1. Prepare the sample area for testing as described in Chapter 4.
2. Take gauge measurements on each area.
3. Take a density measurement using an alternate method.

DENSITY SPECIAL CALIBRATION

The factory calibration provides accurate results for the majority of materials encountered in the field. However, there are situations when varying material compositions and/or texture could affect the gauge accuracy.

The *Special Calibration* function allows the operator to recalibrate the Model 3450 gauge for material characteristics not covered by the factory calibration. The true density is typically determined by measuring samples of a known material in a laboratory.

The *Special Calibration* function is activated only in *Soil* mode.

To access the *Special Calibration* function, press the **<SPECIAL>** key. At the *Special* functions menu, press **<1>** to access the *Special Operation* menu. Press **<1>**, the gauge displays the *Special Calibration* menu:

SP. CAL:Stored Cal	
1-Enable Spec Cal	
2-Disable	4-New
3-View	5-Erase

The gauge displays a special calibration on the first line, if one exists in gauge memory. The following text provides details on the *Special Calibration* function.

Enable a Special Calibration

Use the arrow keys to scroll through the special calibrations. When the gauge displays the desired special calibration, press **<1>**.

The gauge enables the selected special calibration and returns to the *Ready* screen.

Disable a Special Calibration

To disable the last enabled special calibration, press **<2>** at the *Special Calibration* menu. The gauge disables the last enabled special calibration and returns to the *Ready* screen.

View a Special Calibration

Use the arrow keys to scroll through the special calibrations. When the gauge displays the desired special calibration, press **<3>**. The gauge displays:

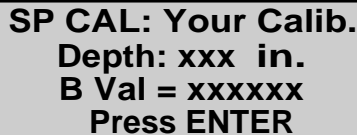

**SP CAL: Your Calib.
Depth: xxx in.
B Val = xxxxxx
Press ENTER**

The gauge displays the special calibration name, depth, and B value. To return to the *Special Calibration* menu, press the **<ENTER>** key. Return to the *Ready* screen by pressing the **<ESC>** key.

Create a Special Calibration

To create a special calibration, the operator must take readings with the gauge and enter the true density. The Model 3450 can store one partial calibration. A partial calibration allows the operator to enter the true density or take readings at different times.

To create a special calibration, press **<4>** at the *Special Calibration* menu (see page 6–11).

Special Calibration
1-Measure Density
2-Input True Density

If a partial calibration was saved earlier, the gauge will display a *P* beside the option entered before (see page 6–15). To take readings for the special calibration, press **<1>** and see *Measuring the Density* below. To enter the true density, press **<2>** and see *Entering True Density* on page 6–14.

MEASURING THE DENSITY. Press **<1>** to select *Measure Density*. Prepare the test site as described on page 4–6. Place the gauge on the test site and position the source rod in the desired measurement position.

NOTE

When using destructive methods (such as drilling cores or sample removal) for true density measurement, take gauge readings before removing samples. Position the gauge over the designated test site as in Figure 6–1.

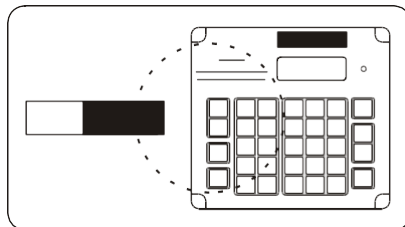

Figure 6–1. Gauge Positioned Over Designated Test Site
Model 3450

The gauge displays:

SPECIAL CALIB
Depth: xxx in
Time 4 min
Press START

Begin the measurement by pressing the **<START>** key. The gauge displays the progress. Then, it displays the reading. Press the **<ENTER>** key.

Special Calibration
1-Input True Density
2-Store Partial
Calibration

To enter the true density now, press **<1>** and follow the gauge prompts to complete the calibration. To enter the true density later, create a partial calibration by pressing **<2>**.

ENTERING TRUE DENSITY. If the measured density has been stored as a partial calibration, return to *Special Calibration* menu as described on page 6–11. The gauge requests the true density:

Input True
Density
xxxx kg/m³
Press ENTER

Use the number keys to enter the true density. Press the **<ENTER>** key.

COMPLETING SPECIAL CALIBRATION. After storing the measured density and true density, enter the desired Special Calibration name.

Edit a Partial Special Calibration

If a partial calibration was saved earlier, the gauge will display a *P* beside the option entered before. Select the value to be completed.

If the value already entered is selected, the gauge prompts the operator to overwrite. To overwrite the partial calibration, press the **<YES>** key and go to page 6–13, *Create a Special Calibration*. To use the stored partial calibration, press the **<NO>** key and select the other value.

To take measurements, see page 6–13. To enter the true density, see page 6–14.

Erase Special Calibrations

At the *Special Calibration* menu (page 6–11), press **<5>**. The gauge displays the *Erase Special Calibration* menu:

<p>SP CAL: Your Special Calib</p> <p>1 Erase This Sp Cal</p> <p>2 Erase All Sp Cal</p>

From the *Erase Special Calibration* menu, the operator can erase either a single special calibration or all special calibrations.

To erase a single special calibration, use the arrow keys to scroll through the special calibrations names displayed on the first line. When the gauge displays the special calibration to be erased, press **<1>**. At the **Are you sure . . .** display, press the **<YES>** key. The gauge erases the special calibration and returns to the *Ready* screen.

To erase all special calibrations, press **<2>** at the *Erase Special Calibrations* menu. At the **Are you sure . . .** display, press the **<YES>** key. The gauge erases all the special calibrations and returns to the *Ready* screen.

THIN LAYER SPECIAL CALIBRATION

The *Thin Lift Special Calibration* function allows the operator to re-calibrate the gauge for materials not covered by the factory calibration. Once a special calibration is enabled, it remains active until the gauge is turned off, or until another calibration is enabled.

The thin layer special calibration uses the average of 3 to 20 measurements. Troxler recommends averaging one-minute readings taken on a test site (see Figure 6–1 on page 6–13) or around a core site (as shown in Figure 6–2). This average and the density obtained by another method (such as core samples) are used to re-calculate the gauge constants.

To access the *Thin Lift Special* functions, press the **(SPECIAL)** key. At the *Special* functions menu, press **(1)** *Special Operation*. At the *Special Operation* menu, press **(2)** *Thin Lift Special*. The gauge displays the *Thin Lift Special* menu:

Thin Spec:Current	
1-Enable Thin Spec	
2-Disable	4-New
3-View	5-Erase

The gauge displays a thin layer special calibration on the first line, if one exists in gauge memory. The following text provides details on the *Thin Lift Special* function.

Enable a Thin Layer Special Calibration

Use the arrow keys to scroll through the thin layer special calibrations. When the gauge displays the thin layer special calibration to be enabled, press **(1)**.

NOTE:

The 3450 gauge must be in *Thin Layer* mode to enable a thin layer special calibration.

The gauge enables the selected thin layer special calibration and returns to the *Ready* screen.

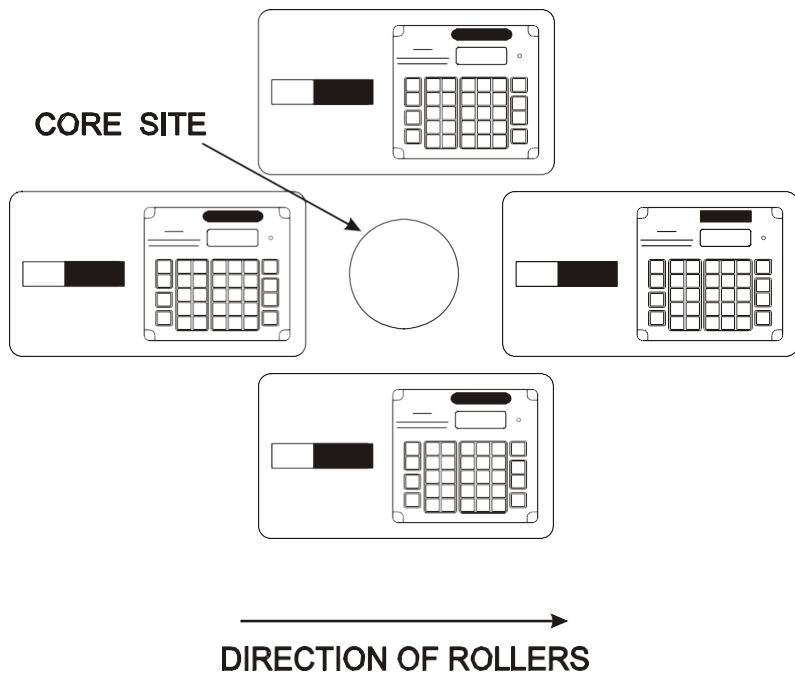

Figure 6–2. Taking Measurements Around a Core Site

Disable a Thin Layer Special Calibration

To disable the last enabled thin layer special calibration, press **<2>** at the *Thin Lift Special* menu. The gauge disables the last enabled thin layer special calibration and returns to the *Ready* screen.

View a Thin Layer Special Calibration

Use the arrow keys to scroll through the thin layer special calibrations. When the gauge displays the thin layer special calibration to be viewed, press **<3>**. The gauge displays:

SP CAL: Your Calib.
B1 Val = xxxx
B2 Val = xxxx
Press ENTER

The gauge displays the thin layer special calibration name and both B values. To return to the *Thin Lift Special* menu, press the **<ENTER>** key. Return to the *Ready* screen by pressing the **<ESC>** key.

Create a Thin Layer Special Calibration

To create a thin layer special calibration, the operator must take readings with the gauge and enter the core density. The gauge uses these values to calculate the thin layer special calibration constants. The Model 3450 can store one partial calibration. A partial calibration allows the operator to enter the asphalt parameters and take readings at different times.

METHOD 1 – MEASURE DENSITY FIRST. To create a thin layer special calibration, press **<4>** *New* at the *Thin Lift Special* menu shown on page 6–16. The gauge displays the *Thin Special Calibration* menu:

**Thin Special Calib
1-Measure Density
2-Input True Density**

If a partial calibration was saved earlier, the gauge will display a *P* beside the option entered before (see page 6–21). To take readings for the thin layer special calibration, press **<1>** and see *Measuring the Density* below. To enter the core density, press **<2>** and see *Entering the True Densities* on page 6–20.

Measuring the Density. Prepare the test site as described on page 4–6. Place the gauge on the test site. Lower the source rod to the backscatter position. Release the trigger and lock the source rod into position. You should hear a *click* when the source rod locks into position.

Go to *Thin Special Calibration* menu and press **<1>** as described above. The gauge displays:

**Input Number of Thin
Lift Averages
— — (3-20)
Then Press ENTER**

When taking counts on thin layer asphalt, Troxler recommends averaging large numbers of readings over the same material to ensure results that are more accurate. Use at least ten (10) gauge readings before cutting cores. Enter the number of measurements the gauge is to average, and press the **<ENTER>** key.

**Ready For
Count 1 Of xx
Place in BS Then
Press START**

With the source rod in the backscatter position, begin the measurement by pressing the **<START>** key. The gauge displays the progress.

After taking the reading, the gauge displays the results and prompts the operator to accept or reject the results. If the operator rejects the results, the gauge retakes the measurement. If the operator accepts the results, the gauge continues to the next measurement.

Reposition the gauge and repeat the above procedure for each count (see Figure 6–2). After taking all the readings, the gauge displays:

**Special Calib
DC= xxxxx xxxxx
Press ENTER**

To enter the true densities now, press **<1>** *Input True Density* and follow the gauge prompts to complete the calibration. To enter the true density later, create a partial calibration by pressing **<2>** *Store Partial Calibration*.

Entering the True Densities. Return to *Thin Special Calibration* menu shown on page 6–18. Follow the gauge prompts to enter the core density.

Completing Thin Special Calibration. After storing measured density and true density, enter the desired Thin Special Calibration name.

METHOD 2 – INPUT TRUE DENSITY FIRST. If the operator chooses **<2>** *Input True Density* from the *Thin Special Calibration* menu shown on page 6–18, and the project was a partial calibration, the gauge displays:



Input Core Density
xxxx kg/m3
Press ENTER

Use the number keys to input the core density and press the **<ENTER>** key to go the next screen. If the project was not a partial calibration, the gauge will skip the *Input Core Density* screen and go directly to the following screen:



Thin Special Calib
1-Measure Density
2-Store Partial
Calibration

To measure the density later, create a partial calibration by pressing **<2>**. To measure the density now, press **<1>**. Prepare the test site as described on page 4–6. Place the gauge on the test site and position the source rod in the measurement position.

The gauge displays:

**Input Number of Thin
Lift Averages
— — (3-20)
Then Press ENTER**

Enter the number of measurements the gauge is to average. Press the **<ENTER>** key.

**Ready For
Count 1 Of xx
Place in BS Then
Press START**

With the source rod in the backscatter position, begin the measurement by pressing the **<START>** key. The gauge displays the progress.

After taking the reading, the gauge displays the results. To continue, press the **<ENTER>** key. Follow the gauge prompts to complete the calibration.

Edit a Partial Thin Layer Special Calibration

If a partial calibration was saved earlier, the gauge will display a *P* beside the option entered before. Select the value to be completed.

If the value already entered is selected, the gauge prompts the operator to overwrite. To overwrite the partial calibration, press the **<YES>** key and go to page 6–18. To use the stored partial calibration, press the **<NO>** key and select the other value.

To take measurements, see page 6–18. To enter the true density, see page 6–20.

Erase Thin Layer Special Calibrations

At the *Thin Lift Special* menu shown on page 6–16, press **<5>** *Erase*. The gauge displays:

SP CAL:
1- Erase This Sp Cal
2- Erase All SpCal

From this menu, the operator can erase either a single thin layer special calibration or all thin layer special calibrations.

To erase a single thin layer special calibration, use the arrow keys to scroll through the thin layer special calibrations names displayed on the first line. When the gauge displays the thin layer special calibration to be erased, press **<1>**. At the **Are you sure . . .** prompt, press the **<YES>** key. The gauge erases the thin layer special calibration and returns to the *Ready* screen.

To erase all thin layer special calibrations, press **<2>**. At the **Are you sure . . .** display, press the **<YES>** key. The gauge erases all the thin layer special calibrations and returns to the *Ready* screen.

APPENDIX A

RADIATION THEORY AND SAFETY

This appendix is required reading for anyone who will use the Troxler Model 3450 RoadReader Plus. This appendix covers topics related to radiation theory and the safe operation of the gauge. A brief overview of the regulatory requirements related to the ownership and use of the gauge, as well as a listing of radiation safety-related warnings and cautions, is included.

CONTENTS

Radiation Theory	A-2
Atomic Structure	A-2
Radioactivity	A-3
Types of Radiation	A-4
Radiation Safety.....	A-5
Radiation Dose	A-5
Limiting Exposure.....	A-6
Personnel Monitoring.....	A-8
Source Encapsulation	A-8
Source Rod Inspection	A-9
Daily Inspection	A-10
Cleaning the Tungsten Blocks.....	A-11
Leak Testing.....	A-13
Regulatory Requirements	A-15
Licensing	A-15
Training	A-15
Disposal.....	A-16
Emergency Procedures.....	A-16
Gauge Use Precautions	A-18
3450 Radiation Profile	A-19

RADIATION THEORY

A more detailed discussion of radiological theory can be found in the *Troxler Nuclear Gauge Safety Training Program* manual, provided at the Troxler Safety Class.

ATOMIC STRUCTURE

All matter is made up of atoms. For example, water has two atoms of hydrogen (H) and one atom of oxygen (O), which in chemical notation is written H_2O .

An atom is made up of a dense nucleus, consisting of positively charged protons and uncharged neutrons, surrounded by a cloud of negatively charged electrons. Under normal circumstances, the number of electrons in an atom equals the number of protons. The number of protons in the atom is called the *atomic number* (Z). A chemical element consists of all atoms having the same atomic number.

The number of protons plus neutrons in the nucleus is called the *atomic mass* (A). Atoms of a given chemical element can exist in slightly different variants called *isotopes* that have different atomic masses. For example, carbon-12 (C-12) is non-radioactive and carbon-14 (C-14) is radioactive. Isotopes that are radioactive are termed radioisotopes or radionuclides.

Figure A-1 depicts a helium atom consisting of two protons and two neutrons in the nucleus and two orbiting electrons.

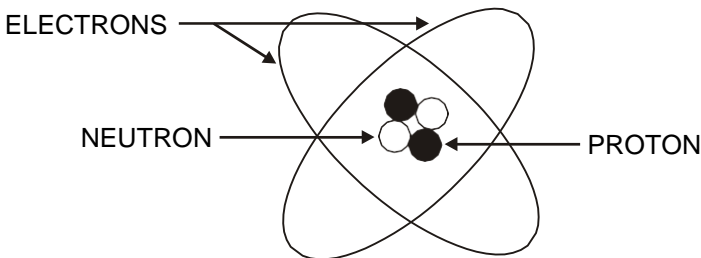

Figure A-1. Diagram of an Atom

RADIOACTIVITY

Radioactivity is the spontaneous transformation (or disintegration) of an unstable nucleus into a more stable configuration accompanied by the emission of radiation.

The quantity of a radioactive material is measured in terms of the average number of nuclear disintegrations per unit time. The traditional unit of measure for radioactivity (or *activity*) is the *curie* (Ci), which is defined as 3.7×10^{10} disintegrations per second. The activities of the radioactive sources in nuclear gauges are so small that they are typically measured in *millicuries* (mCi), which is one-thousandth of a curie, or *microcuries* (μ Ci), which is one-millionth of a curie.

In the Standard International (SI) (or *metric*) system, the unit of activity is the *becquerel* (Bq), which equals one disintegration per second. Because the becquerel is such an extremely small unit, the activity of sources in nuclear gauges is normally expressed in *megabecquerel* (MBq), which is one million bequerals, or *gigabecquerel* (GBq), which is one billion Bq.

The radioactivity of a source is not constant, but decreases with time as the source decays. The time it takes for one-half of the original atoms to disintegrate is called the *half-life*. In successive half-lives, the activity decreases to 1/2, 1/4, 1/8 and so on of the initial value. After seven half-lives, less than 1% of the original radioactive atoms remain. Each radioisotope has a characteristic half-life, which can range from seconds to billions of years. The half-lives for the typical radioisotopes used in nuclear gauges are:

Radioisotope	Half-life
Cs-137	30 years
Am-241	432 years

TYPES OF RADIATION

The radioactive sources in the Model 3450 produce four types of radiation:

- Alpha particles
- Beta particles
- Gamma rays (photons)
- Neutrons

The alpha and beta particles are stopped by the source capsule. Therefore, they present no external hazard to personnel. Only the gamma and neutron radiation from sealed sources contribute to any occupational radiation exposure.

Gamma rays (photons) are a type of electromagnetic radiation, like X rays, radio waves, and visible light. Photons have no mass or electrical charge, and travel at the speed of light. Gamma rays are energetic and penetrating. Dense materials (such as lead, tungsten, and so on) provide the best shielding against gamma radiation.

Neutrons are a form of particulate radiation but, unlike alpha and beta particles, they have no electrical charge. This makes neutron radiation very penetrating. Fast neutrons lose energy primarily by so-called “billiard ball” elastic collisions with the nuclei of low atomic number atoms, especially hydrogen. The best shielding materials for fast neutrons are those with a high hydrogen content, such as water, concrete, and polyethylene.

RADIATION SAFETY

This section discusses the principles of general radiation safety. This information includes specific procedures for operating, inspecting, cleaning, and leak testing the gauge to ensure safe operation..

RADIATION DOSE

Ionization cannot be detected by any of the human senses (sight, touch, hearing, smell). However, using appropriate instruments and devices, ionization can be detected and measured at levels far below those that significantly affect health.

For purposes of radiation protection, the basic unit of radiation dose is the *rem*. The SI unit is the *sievert* (Sv), where 1 Sv = 100 rem. The rem is a relatively large unit, so often radiation dose is expressed in smaller units called millirem (mrem), where 1 rem = 1000 mrem.

The risk of injury from radiation is generally related to the total radiation dose received over a period of time. It is also related to the dose rate, which is the amount of dose received per unit time. The same amount of radiation received over a long period (months to years) is much less hazardous than if received over a very short period (hours). This has to do with the body's ability to repair cell damage caused by the radiation.

The U.S. Nuclear Regulatory Commission (NRC) has established the following limits on the amount of whole body radiation exposure that individuals may safely receive from licensed radioactive materials.

Type of Individual	Dose Limit
Adult worker	5000 mrem per year
Minor (under 18 years old)	500 mrem per year
Member of the public	100 mrem per year

LIMITING EXPOSURE

Under average conditions, an individual working with the 3450 gauge will receive less than 200 millirem per year.

A basic principle of radiation protection is that radiation exposure should be kept as far below the limits as is reasonably achievable. This is known as the *ALARA* (as low as reasonable achievable) principle. The three methods for limiting exposure are:

Time

Distance

Shielding

Time

The simplest way to reduce exposure is to minimize the time spent around a radioactive source. If the time spent near a source is cut in half, then the exposure is halved, all other factors remaining constant.

Distance

Distance is another effective means to reduce radiation exposure. A formula known as the *inverse square law* relates the radiation exposure rate to distance (Figure A-2). Doubling the distance from a radiation source reduces the exposure to one-fourth its original value. If the distance is tripled, then the exposure is reduced by a factor of nine, and so on.

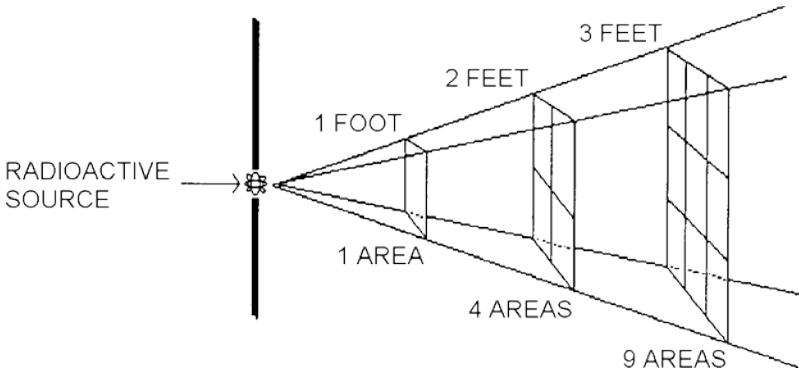

Figure A-2. Effect of Distance on Exposure

Shielding

Shielding is any material used to reduce the radiation exposure rate from a radioactive source. The 3450 gauge has some built-in shielding, which reduces the exposure rate. When gauges are in storage, additional shielding may be necessary to keep exposure to personnel in adjacent areas below the dose limits for members of the public.

The thickness of any material that reduces the incident radiation intensity by one-half is known as the *half-value layer (HVL)*. The HVL of a material varies with the type and energy of radiation. The HVL values of certain common shielding materials are shown below for gamma and fast neutron radiation.

Material	Cs-137 Gamma Half-Value Layer	Am-241:Be Neutrons Half-Value Layer
Concrete	1.9 inches	4.3 inches
Lead	0.3 inches	*

- * Lead does not provide any effective shielding of fast neutrons.

PERSONNEL MONITORING

In the United States, anyone working with or near radioactive materials is subject to occupational dose limits. Individual monitoring of each authorized user is recommended in order to demonstrate compliance with these dose limits.

The most common types of individual monitoring devices used by licensees are film badges and thermoluminescent dosimeter (TLD) badges. Film badges are typically exchanged and processed monthly due to concerns about film fading. TLD badges are usually exchanged quarterly. Troxler offers NVLAP-certified personnel monitoring services using TLD badges.

In Canada, nuclear gauge users are not normally classified as Atomic Radiation Workers. In such cases, the general public dose limit of 500 mrem/year applies. Users may not be required to wear a dosimeter. To establish the personnel monitoring requirements for your application, consult the conditions of your radioisotope license and the CNSC regulatory document *R91: Monitoring and Dose Recording for the Individual*.

SOURCE ENCAPSULATION

The neutron (Am-241:Be) and photon (Cs-137) source materials are welded inside stainless steel capsules. These sealed sources meet U.S. and international regulatory requirements for classification as “Special Form” radioactive material for purposes of transportation. The sealed sources are designed to prevent leakage of radioactive material under severe accident conditions. They are also designed to comply with applicable ANSI classification requirements for sealed sources used in portable gauges.

SOURCE ROD INSPECTION

To ensure the integrity of the source rod, Troxler recommends that a qualified Troxler service person inspect the gauge and the source rod at least once every five years. This inspection includes checking for excessive wear, corrosion, or damage that could affect the safety of gauge operation.

✓ However, as a precaution, ensure that the tip of the source rod is intact and undamaged (that is, ensure that the source is not missing). Use a radiation survey meter to check the radiation levels at the gauge base surface (without extending the source rod). A maximum reading of 10-20 mrem/hr is normal, and indicates the source is present. However, if the maximum reading is less than 1 mrem/hr or if a survey meter is not available, perform a visual inspection of the source rod tip as follows to confirm its integrity:

1. Extend the source rod just far enough to see the source rod tip. The tip should appear flat to slightly rounded and smooth.
2. Stay at least three feet away from the tip of the unshielded source rod and complete the inspection as quickly as possible to minimize exposure (the dose rate at three feet from the unshielded source is about 2.7 mrem/hr).

If the visual inspection indicates that the source rod tip is broken off (source is missing):

1. Immediately contact your Radiation Safety Officer (RSO).
2. Initiate a search for the source starting at the location where the gauge was last used.
3. Report lost or missing radioactive sources to the state or federal radiation control agency in accordance with applicable regulatory requirements.

Contact the Troxler Radiation Safety Department for further advice.

DAILY INSPECTION

The gauge should be inspected daily before use to ensure proper operation of all safety features as follows:

- ✓ The source rod opening in the bottom of the gauge is equipped with a spring-loaded tungsten sliding block that shuts when the source rod is in the **SAFE** (shielded) position. To check the operation of the sliding block, push the source rod down into the backscatter position (see Figure 3–3 on page 3–5), and then raise it back to the **SAFE** position. You should hear a *click* as the sliding block snaps shut. Turn the gauge over and verify that the sliding block is shut. If any portion of the opening is uncovered, the tungsten sliding block and fixed tungsten block should be cleaned before using, transporting, or storing the gauge. Refer to page A–11 for instructions on cleaning the sliding and fixed blocks.

NOTE

The bottom edge of the tungsten sliding block is beveled, as shown in Figure A–3 on page A–12. As a result, there may appear to be a slight opening when the sliding block is closed. However, you should hear a *click* as the sliding block snaps shut when the source rod is raised to the **SAFE position.**



WARNING

Do not store or transport the gauge unless the sliding block is closed. Increased radiation levels may cause excessive personnel radiation exposure and may violate transportation regulations.

- ✓ If a radiation survey instrument is available, verify that the radioactive gamma source is in place by measuring the exposure rate at the surface of the gauge. The exposure rate should be approximately 10–20 mrem per hour. A reading of about 1 mrem or less indicates either that the survey instrument is not working properly or that the cesium-137 source may be missing. Refer to the *Troubleshooting* section on page C–9 for further instructions.

CLEANING THE TUNGSTEN BLOCKS

If the tungsten sliding block and the fixed tungsten block are not kept clean, the sliding block may stick partially or completely open when the source rod is raised to the **SAFE** (shielded) position. This will result in high radiation levels near or in line with the source rod opening on the bottom of the gauge. After cleaning and reassembling the gauge as described below, check the operation of the sliding block by pushing the source rod into the backscatter position, then returning it to the **SAFE** position. You should hear a *click* as the sliding block snaps shut. Inspect the opening on the base of the gauge to confirm that the sliding block is closed. If not, check that the sliding block spring was properly installed after cleaning. If the sliding block still does not close properly, immediately contact the nearest Troxler Service Center.



WARNING

Do not store or transport the gauge unless the sliding block is closed. Increased radiation levels may violate transportation regulations, and may cause excessive personnel radiation exposure.

The tungsten sliding block and the fixed tungsten block may require cleaning if the source rod becomes difficult to lower into the “measure” position, or if a *click* is not heard when the source rod is raised to the **SAFE** (shielded) position. An improperly operating sliding block may also result in erratic or incorrect density readings and increased radiation levels.



WARNING

Removal of the sliding block results in dose rates of up to one rem per hour in the path of the beam. Stand clear of the gauge bottom while performing this procedure and proceed as quickly as possible while working in the cavity to minimize exposure to your extremities.

- ✓ With the source rod in the **SAFE** (shielded) position, place the gauge on its side.
- ✓ Clean the heads of the four corner screws that hold the bottom plate to the gauge base (Figure A–3). Using a 1/8-in. Allen wrench, remove the four screws in the corner of the plate and remove the plate. **Do not remove** the two screws located in the center of the plate that secure the fixed block to the plate.
- ✓ To reduce radiological exposure, stand to one side of the gauge. Paying close attention to the position of the sliding block, remove the block.
- ✓ Using a stiff brush or rag soaked in alcohol, clean the sliding block, the fixed block mounted on the bottom plate, and the cavity.
- ✓ Re-install the sliding block with the angled side up. Apply a light coating of Magnalube-G paste to the **top angled** surface of the sliding block and to the top surface of the fixed block.
- ✓ Re-install the bottom plate. **Do not over-tighten screws!** Ensure that the source rod moves up and down freely.

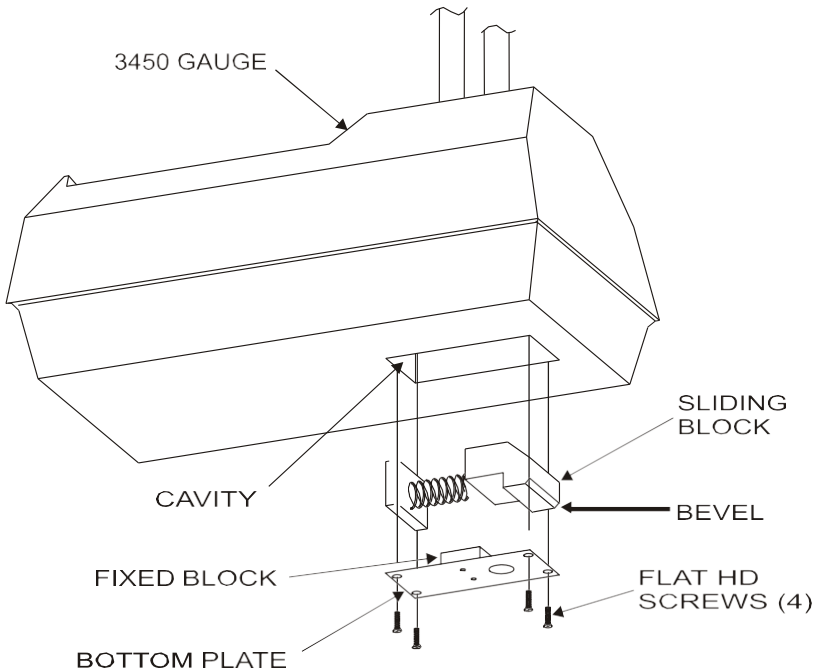

Figure A–3. Cleaning the Sliding and Fixed Blocks

LEAK TESTING

The 3450 gauge contains two radioactive sources that must be periodically leak tested. The purpose of leak testing is to verify the integrity of the source encapsulation. Because the source capsules are not directly accessible to users, the leak test is performed indirectly by testing gauge components near the capsules for contamination. Unless specified otherwise by your radioactive material license, the 3450 gauge must be leak tested at intervals not exceeding 12 months to verify the integrity of the radioactive sources contained in the gauge. In the United States, leak tests may only be performed by an organization licensed to provide leak test kits to licensees and to analyze leak test samples.

To perform a leak test, use the Troxler Model 3880 Leak Test Kit (PN 102868) and accompanying instructions to perform the following procedure:

- ✓ Write the gauge model and serial number on the wipe disk.
- ✓ Ensure that the source rod is latched in the **SAFE** (shielded) position.
- ✓ Loosen the four captive screws that secure the control unit, and remove the control unit from the gauge (Figure A-4).
- ✓ Look into the interior of the gauge and locate the baseboard assembly attached to the gauge base. The baseboard assembly consists of printed circuit (PC) boards in an aluminum housing.
- ✓ Holding the wipe disk with the tongs, wipe the gauge base and aluminum housing in front of and behind the baseboard in the middle of the gauge (approximately halfway between the source rod and the right hand side of the gauge).
- ✓ Return the control unit to the gauge and tighten the four captive screws.
- ✓ Turn the gauge on its side and locate the opening on the bottom of the gauge through which the source rod would protrude.

- ✓ Holding the wipe disk with the tongs, wipe around and in this opening.
- ✓ Pack the disk in the envelope as instructed, and mail to Troxler Electronic Laboratories, Inc. for analysis.
- ✓ Secure the gauge properly.

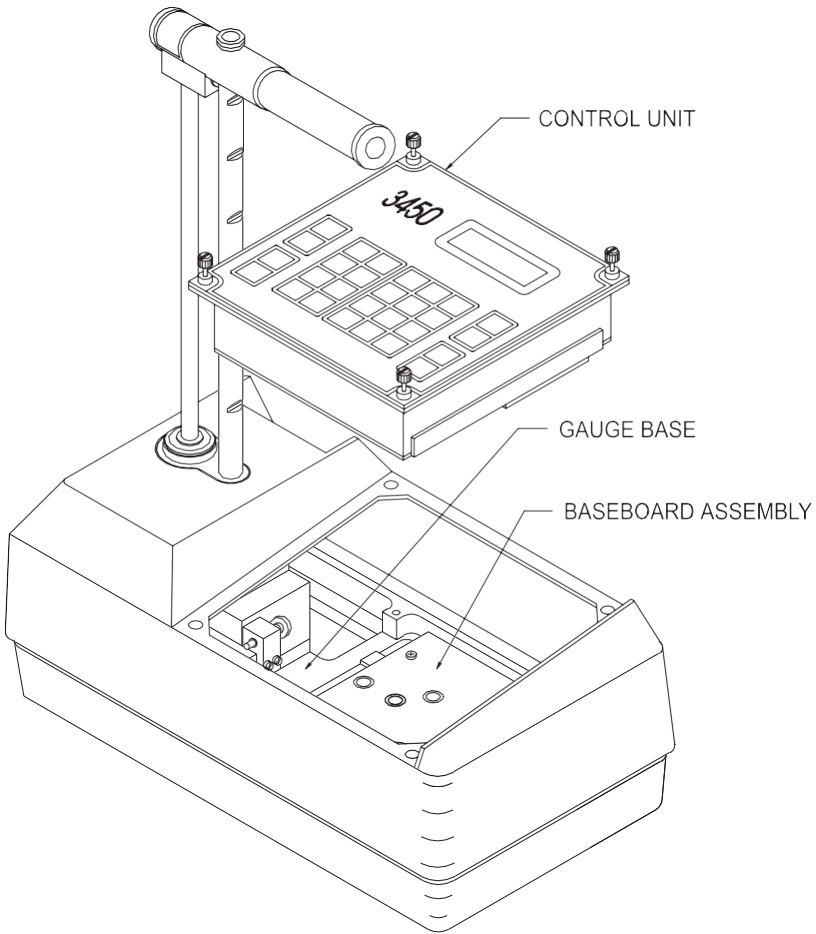

Figure A-4. Performing a Leak Test

REGULATORY REQUIREMENTS

This section summarizes the licensing and training requirements that pertain to ownership or operation of a nuclear gauge. This section also provides information on the proper disposal of the gauge, as well as emergency procedures to follow if the gauge is lost, stolen, or damaged.

LICENSING

In the United States, possession and use of the radioactive materials in a nuclear gauge require a license issued by the U.S. Nuclear Regulatory Commission (NRC) or an Agreement State licensing agency. Detailed information on obtaining a license is contained in the *Troxler Licensing Guide*. Copies of this guide are available from Troxler, or can be downloaded from the Troxler website, www.troxlerlabs.com.

To purchase a nuclear gauge in Canada, an owner must obtain a radioisotope license from the Canadian Nuclear Safety Commission (CNSC). The owner should obtain copies of the CNSC Regulations and the Transportation of Dangerous Goods Act and Regulations. For other countries, please consult your local regulatory agency.

TRAINING

In the United States, anyone working with or near radioactive materials must complete a radiation safety training course to be designated an *authorized user*. Authorized users must be trained in the precautions and procedures to minimize radiation exposure; applicable regulatory requirements; and the operating, emergency, maintenance, and transportation procedures for the gauge. Troxler offers training classes designed to meet regulatory agency training requirements for nuclear gauge users.

DISPOSAL

A nuclear gauge contains licensed radioactive material. At the end of a gauge’s service life, it must not be discarded as ordinary trash, recycled as scrap material, or abandoned. Instead, a nuclear gauge must be transferred to an authorized recipient licensed by the NRC or an Agreement State. For further information on gauge disposal, contact Troxler.

EMERGENCY PROCEDURES

If the nuclear gauge is lost or stolen, then immediately notify the gauge owner’s Radiation Safety Officer (RSO).

The gauge owner should complete the emergency contact information on the lines furnished below. (Note that *company* refers to the gauge owner’s company, not Troxler Electronic Laboratories.) This information should be readily available to the gauge operator at all times.

The company RSO is _____
Call the RSO at _____
The regulatory agency is _____
Call the agency at _____

If a gauge is damaged, then follow the steps below:

1. Locate the gauge and/or sources.
2. Do not touch or move the gauge.
3. Immediately rope off an area around the nuclear gauge and/or sources. A radius of 15 ft (5 m) is sufficient. Do not leave the area unattended.
4. Keep all unauthorized personnel from the nuclear gauge.

5. If a vehicle is involved, it must be stopped until the extent of contamination, if any, can be established.
6. The gauge user should perform a visual inspection of the nuclear gauge to determine if the source housing or shielding has been damaged.
7. Use a survey meter (such as the TroxAlert Survey Meter) to measure the dose rate at a distance of one meter (3 ft) from the gauge.
8. Contact the company RSO (name and number given at the beginning of this section). Provide the RSO with the following:
 - a. The date, time, and location of the accident
 - b. The gauge model and serial number
 - c. The nature of the accident
 - d. The location and condition of the gauge and/or source
 - e. The dose rate at 3 ft (1 m) from the gauge
9. If you are unable to reach the RSO, then call your regulatory agency (name and number given at the beginning of this section).
10. Follow the instructions of the RSO. The RSO may need to report the incident to the regulatory agency. The RSO may also be required to notify the USDOT of accidents during transport.
11. Before shipping a damaged gauge to Troxler, obtain an RGA (Returned Goods Authorization) number from the Troxler Customer Service Department, as described in the *Returning the Gauge for Service* section on page C-30.

GAUGE USE PRECAUTIONS

The following precautions should be observed when transporting, storing, maintaining, or operating the gauge.

- ◆ Never touch the unshielded tip of the source rod with your bare hands. The dose rates on contact with the source rod tip can result in exposures exceeding the annual dose limits to the skin of the extremities within a short time period (about 1 hour).
- ◆ When not taking readings, always keep the source rod in the **SAFE** (shielded) position. For added user safety, the source rod automatically retracts to the **SAFE** position when the gauge is lifted by the handle.
- ◆ If you do not hear a *click* when the gauge is raised to the **SAFE** position, look at the bottom of the gauge to verify that the tungsten sliding block is completely closed. If the gauge base opening is not completely closed by the sliding block, the sliding block and fixed tungsten block may require cleaning. Refer to Appendix C for cleaning instructions.
- ◆ Do not store or transport the gauge unless the sliding block is completely closed. Increased radiation levels may cause excessive personnel radiation exposure and may violate transportation regulations.
- ◆ When preparing a test site, use the drill rod assembly to drill the test hole. **Under no circumstances should the source rod of the gauge be used to drill holes.**
- ◆ Do not tamper with or modify the 3450 gauge. Also, do not remove the sealed source from the gauge. Tampering with or modifying the gauge or removing the sealed source can be dangerous. Such actions are illegal unless authorized by your radioactive materials license.

3450 RADIATION PROFILE

Table A-1 shows the radiation profile for the Model 3450 gauge. The table lists the radiation dose equivalent rates (in mrem/hour) for each side of the gauge and transport case shown in Figure A-5.

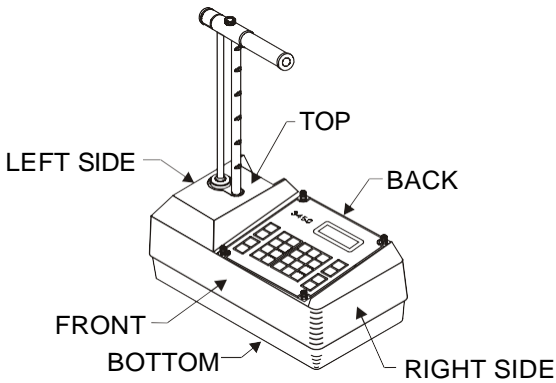

GAUGE

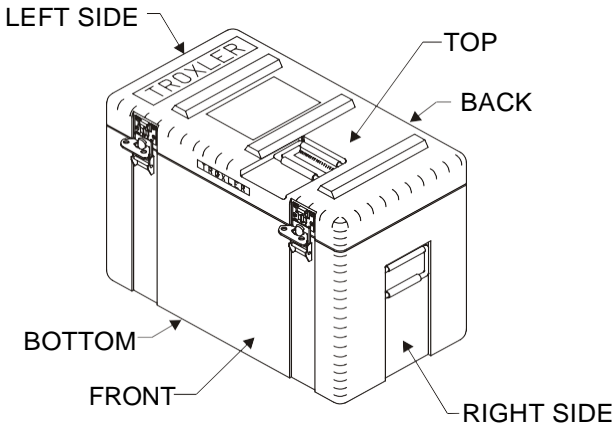

TRANSPORT CASE

Figure A-5. Model 3450 Gauge and Transport Case

*Table A-1. Radiation Profile for Model 3450 Gauge
(Dose Rate in Millirem per Hour)*

	Surface			5 cm			30 cm			100 cm		
	Gamma	Neutron	Total	Gamma	Neutron	Total	Gamma	Neutron	Total	Gamma	Neutron	Total
GAUGE												
Front	6.5	N/A	6.5	3.5	N/A	3.5	0.8	0.3	1.1	0.1	0.1	0.2
Back	14.0	N/A	14.0	7.0	N/A	7.0	0.7	0.5	1.2	0.14	0.1	0.24
Left Side	11.0	N/A	11.0	3.5	N/A	3.5	0.8	0.1	0.9	0.1	0.0	0.1
Right Side	3.5	N/A	3.5	2.5	N/A	2.5	1.0	0.3	1.3	0.25	0.07	0.32
Top	14.0	N/A	14.0	6.0	N/A	6.0	1.7	0.35	2.05	0.3	0.1	0.4
Bottom	14.0	N/A	14.0	10.0	N/A	10.0	1.6	0.25	1.85	0.2	0.05	0.25
GAUGE IN TRANSPORT CASE												
Front	7.0	N/A	7.0	3.0	N/A	3.0	0.5	0.1	0.6	0.12	0.0	0.12
Back	2.0	N/A	2.0	1.5	N/A	1.5	0.9	0.3	1.2	0.2	0.05	0.25
Left Side	0.2	N/A	0.2	0.15	N/A	0.15	0.08	0.5	0.58	0.0	0.05	0.05
Right Side	5.0	N/A	5.0	2.5	N/A	2.5	0.5	0.55	1.05	0.15	0.1	0.25
Top	5.0	N/A	5.0	4.0	N/A	4.0	1.0	0.35	1.35	0.15	0.05	0.2
Bottom	5.0	N/A	5.0	3.5	N/A	3.5	0.85	0.25	1.1	0.15	0.1	0.25

Survey Equipment Used:

Gamma: Ludlum Model 14C Survey Meter, serial #57418, calibrated 10/02/1996.

Neutron: Snoopy Portable Neutron Doserate Meter, model#NP-2, serial #NP183404, calibrated 12/07/1995.

NOTES:

1. All tabulated values are in units of mrem/hr.
2. The orientation of the gauge in the transport case is as follows:
 - a. Back of gauge to front of case.
 - b. Bottom of gauge to right side of case
 - c. Top of gauge to left side of case
3. Dose rates measured by the State of North Carolina Department of Environment and Natural Resources, Division of Radiation Protection.
4. Dose equivalent rates for 8 mCi Cs-137 and 40 mCi Am-241:Be.
5. Surface indicates surface of the gauge or surface of the transport case.

APPENDIX B

3450 SPECIFICATIONS

This appendix contains gauge and measurement specifications for the Troxler Model 3450 RoadReader Plus.

CONTENTS

Measurement Specifications	B-2
Soil and Asphalt Modes	B-2
Thin Layer Mode.....	B-4
Radiological Specifications	B-5
Electrical Specifications	B-6
Mechanical Specifications	B-8

MEASUREMENT SPECIFICATIONS

SOIL AND ASPHALT MODES

SI Units

Density at 2000 kg/m³

Direct Transmission (150 mm)

	15 sec	1 min	4 min
Precision (kg/m ³)	5.2	2.6	1.3
Composition error (kg/m ³)	8.0	8.0	8.0
Surface error (1.25 mm, 100% Void) (kg/m ³)	-18.0	-18.0	-18.0

Backscatter

	15 sec	1 min	4 min
Precision (kg/m ³)	16.0	8.0	4.0
Composition error (kg/m ³)	14.0	14.0	14.0
Surface error (1.25 mm, 100% Void) (kg/m ³)	-80.0	-80.0	-80.0

Moisture at 240 kg/m³

	15 sec	1 min	4 min
Precision (kg/m ³)	11.0	5.5	2.8
Surface error (1.25 mm, 100% Void) (kg/m ³)	-19.0	-19.0	-19.0

U.S. Customary Units

Density at 125 pcf

Direct Transmission (6 in.)

	15 sec	1 min	4 min
Precision (pcf)	0.32	0.156	0.08
Composition error (pcf)	0.50	0.50	0.50
Surface error (0.05 in., 100% Void) (pcf)	-1.1	-1.1	-1.1

Backscatter

	15 sec	1 min	4 min
Precision (pcf)	1.0	0.50	0.25
Composition error (pcf)	0.87	0.87	0.87
Surface error (0.05 in., 100% Void) (pcf)	-5.0	-5.0	-5.0

Moisture at 15 pcf

	15 sec	1 min	4 min
Precision (pcf)	0.69	0.34	0.17
Surface error (0.05 in., 100% Void) (pcf)	-1.2	-1.2	-1.2

THIN LAYER MODE

Precision at 2240 kg/m³ (140 pcf)

<u>Time (min)</u>	<u>Thickness</u>	<u>kg/m³</u>	<u>pcf</u>
1.0	2.5 cm (1.0 in.)	±16	±1.0
	5.0 cm (2.0 in.)	±10	±0.60
	6.3 cm (2.5 in.)	±8	±0.50
	10.0 cm (4.0 in.)	±8	±0.5
4.0	2.5 cm (1.0 in.)	±8	±0.50
	5.0 cm (2.0 in.)	±5	±0.30
	6.3 cm (2.5 in.)	±4	±0.25
	10.0 cm (4.0 in.)	±4	±0.25

Precision is defined as ±one standard deviation in readings.

RADIOLOGICAL SPECIFICATIONS

Gamma Source	0.30 GBq (8 mCi) \pm 10% Cs-137
Neutron Source	1.48 GBq (40 mCi) \pm 10% Am-241:Be
Source Type	Sealed Source – Special Form
Source Housing	Stainless Steel, Encapsulated
Shielding	Lead, Tungsten
Surface Dose Rate	See Radiation Profile on page A-19
Shipping Case	Type A, Yellow II, TI = 0.3
Certificates of Competent Authority	Cs-137 – USA/0614/S or USA/0356/S Am-241:Be – USA/0632/S or CZ/1009/S

ELECTRICAL SPECIFICATIONS

Stored Power	32 watt-hours
Average Power Consumption	
Idle mode	0.12 watts
Measurement mode	0.17 watts
Standby	0.06 watts
Backlight	0.6 watts
Default Time Before Sleep Mode	30 seconds between keypresses, no loss of data or previous status
Time Before Automatic Shutdown	5 hours of complete inactivity
Power Source(s):	
Base	4 Sub-C NiCad (Rechargeable Pack) batteries
Control Unit	6 AA alkaline batteries
Charge Source	10-14 V dc, 650 mA minimum
Battery Recharge Time	4 hours maximum, automatic cutoff (may be charged incrementally without damaging the batteries)
Liquid Crystal Display	Alphanumeric, 4 line × 20 character, backlit
Keypad	33-key sealed membrane
Random-Access Memory (RAM)	128 kilobytes non-volatile
Serial Data Format	1 stop bit No parity 8 data bits

3450 to PC Computer Cable (Null Modem Cable)

9 pin FEMALE	9 pin FEMALE
Rx (pin 2)	Tx (pin 3)
Tx (pin 3)	Rx (pin 2)
DTR (pin 4).....	DSR (pin 6)
DSR (pin 6).....	DTR (pin 4)
RTS (pin 7)	CTS (pin 8)
CTS (pin 8)	RTS (pin 7)
Gnd (pin 5).....	Gnd (pin 5)

3450 to Weigh-Tronix→ Printer Cable

9 pin FEMALE	25 pin MALE
TXD (pin 3).....	RXD (pin 2)
CTS (pin 8)	CTS (pin 5)
GND (pin 5).....	GND (pin 7)
DSR (pin 6)	
DTR (pin 4)	

MECHANICAL SPECIFICATIONS

Gauge Size (w/ handle)	12-inch rod: 604 H × 411 L × 229 W mm (23.8 H × 16.2 L × 9.0 W in.)
	8-inch rod: 503 H × 411 L × 229 W mm (19.8 H × 16.2 L × 9.0 W in.)
Shipping Case Size	782 H × 353 L × 455 W mm (30.8 H × 13.9 L × 17.9 W in.)
Weight	17 kg (37.5 lb)
Shipping Weight	43 kg (96.0 lb)
Operating Temperature (Ambient)	0 to 70 °C 32 to 158 °F
Max Test Material Surface Temperature	175 °C (347 °F) for 15 minutes
Storage Temperature	-55 to 85 °C -67 to 185 °F
Humidity	98%, noncondensing

CAUTION

This instrument contains sensitive electronic and nuclear components. This instrument *must not* be subjected to stress, abuse, or use other than in accordance with the standard operating procedures listed in this manual.

APPENDIX C

TROUBLESHOOTING AND SERVICE

This appendix provides details for troubleshooting and servicing the Troxler Model 3450 RoadReader Plus. For further details, call the nearest Troxler Service Center or representative.

CONTENTS

Stat Test	C-3
Taking a Stat Test.....	C-4
Reviewing the Stat Test.....	C-4
Printing the Stat Test.....	C-4
Drift Test.....	C-5
Taking a Drift Test	C-6
Reviewing the Drift Test	C-6
Printing the Drift Test.....	C-7
Source Decay	C-8
Troubleshooting.....	C-9
Error Messages.....	C-14
Batteries	C-18
Battery Status	C-19
Charging.....	C-20
Replacing the Batteries.....	C-20
Mechanical Maintenance	C-22
Cleaning the Base and Top Shell	C-22
Lubricating the Source Rod.....	C-23
Replacing Gaskets	C-24

CONTENTS (Continued)

- Leak Testing C-25
 - Leak Test Date C-25
 - Leak Test Interval C-26

- Display Contrast C-27

- Replacement Parts C-28
 - Accessories C-29
 - Options C-29
 - Maintenance Supplies C-29

- Returning the Gauge for Service C-30



STAT TEST

Erratic readings, or readings that seem to fluctuate, may indicate a problem with the gauge. If the readings are suspect, perform a *stat test*, or statistical stability test, to validate the normal operation of the gauge.

A stat test consists of 20 one-minute counts. From the 20 counts, the gauge calculates the standard deviation. This standard deviation is compared to a theoretical standard deviation value. Ideally, this ratio should be 0.354, with acceptable limits from 0.225 to 0.465. The gauge is considered unstable if the ratio is outside these limits and the stat test will fail. If the stat test fails, ensure that the gauge setup and testing was conducted correctly, and take an additional test. If the second test fails, call the nearest Troxler service center for assistance.

To access the *Stat Test* menu, press the **<SPECIAL>** key. At the *Special functions* menu, access the *Gauge Status/Test* menu by pressing **<2>**. At the *Gauge Status/Test* menu, press **<2>**. The gauge displays the *Stat Test* menu:

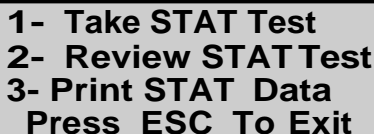

```
1- Take STAT Test
2- Review STAT Test
3- Print STAT Data
Press ESC To Exit
```

The following text provides details on the stat test function.

TAKING A STAT TEST

Choose an area free of other nuclear gauges or radioactive sources. Place the gauge on the reference standard block as shown in Figure 4-1 on page 4-3.

To take a new stat test, press **<1>** at the *Stat Test* menu. The gauge prompts the operator to place the gauge on the reference standard block with the source rod in the **SAFE** (shielded) position. Ensure that the gauge is properly positioned and press the **<ENTER>** key.

The gauge displays the progress of the stat test. After taking the stat test, the gauge displays the average counts and indicates if the test passed or failed. If the stat test *fails*, see page C-3. Press the **<ENTER>** key to return to the *Stat Test* menu, or press the **<ESC>** key to return to the *Ready* screen.

REVIEWING THE STAT TEST

To review the results of the last stat test, press **<2>** at the *Stat Test* menu (see page C-3). The gauge displays the results of the last stat test. To scroll through the data, use the arrow keys. Press the **<ENTER>** key to return to the *Stat Test* menu, or press the **<ESC>** key to return to the *Ready* screen.

PRINTING THE STAT TEST

The operator can print or upload the results of the stat test to either a printer or a computer. For details on setting up the printer, see page 3-13.

To print the results of the last stat test, press **<3>** at the *Stat Test* menu (see page C-3). The gauge prompts the operator to connect the printer to the gauge. Connect the gauge to the printer (or computer) as described on page 5-7. Follow the gauge prompts to print the data.

The gauge prints or uploads the stat test data and returns to the *Stat Test* menu. To return to the *Ready* screen, press the **<ESC>** key.

DRIFT TEST

If the gauge passes the stat test, but shows long-term drift between measurements, perform a *drift test* to check the long-term drift of the gauge. A drift test consists of five counts taken 3 to 8 hours after a stat test *with no movement of the gauge between tests*. The gauge sets the pass/fail limits based on the percent difference between the average of the stat test and drift test results. If the percent difference exceeds 0.5 percent for density counts or 1 percent for moisture counts, then the drift test fails. If the drift test fails, ensure that the gauge setup and testing were conducted correctly, and take an additional test. If the second test fails, call the nearest Troxler service center for assistance.

NOTE

The drift test consists of five 4-minute count, whereas the stat test consists of twenty 1-minute counts. Therefore, each test takes approximately twenty minutes to conduct. DO NOT turn the gauge off between a stat test and a drift test. The drift test should be taken in the same location as the stat test.

DO NOT move the gauge between the stat and drift tests to eliminate possible failure due to positioning changes.

To access the *Drift Test* menu, press the **<SPECIAL>** key. At the *Special* functions menu, access the *Gauge Status/Test* menu by pressing **<2>**. At the *Gauge Status/Test* menu, press **<3>**. The gauge displays the *Drift Test* menu:

<p>1- Take Drift Test 2- Review Drift Test 3- Print Drift Data Press ESC To Exit</p>
--

The following text provides details on the drift test.

TAKING A DRIFT TEST

With the gauge still in an area free of other nuclear gauges or radioactive sources and on the reference standard block, press **<1>** at the *Drift Test* menu shown above.

NOTE

If it has been less than four hours or more than eight hours since the last stat test, then the gauge allows the operator to exit the drift test. To exit and take another stat test, press the **<YES> key at the prompt. To continue with the drift test, press the **<NO>** key at the prompt.**

The gauge prompts the operator to place the gauge on the reference standard block with the source rod in the **SAFE** (shielded) position. Ensure that the gauge is positioned properly and press the **<ENTER>** key.

The gauge displays the progress of the drift test. After taking the drift test, the gauge displays the average counts and indicates if the test passed or failed. If it fails, see page C-3 for instructions. Press the **<ENTER>** key to return to the *Drift Test* menu, or press the **<ESC>** key to return to the *Ready* screen.

REVIEWING THE DRIFT TEST

To review the results of the last drift test, press **<2>** at the *Drift Test* menu (see page C-5). The gauge displays the results of the last drift test. To scroll through the data, use the arrow keys. Press the **<ENTER>** key to return to the *Drift Test* menu, or press the **<ESC>** key to return to the *Ready* screen.

PRINTING THE DRIFT TEST

The operator can print or upload the results of the drift test to either a printer or a computer. For details on setting up the printer, see page 3–13.

To print the results of the last drift test, press **<3>** at the *Drift Test* menu (see page C–5). The gauge prompts the operator to connect the printer to the gauge. Connect the gauge to the printer (or computer) as described on page 5–7. Follow the gauge prompts to print the data.

The gauge prints the drift test data and returns to the *Drift Test* menu. To return to the *Ready* screen, press the **<ESC>** key.

SOURCE DECAY

The strength of radioactive material is measured by its activity, or rate of decay. This activity decreases with time. The length of time it takes a given amount of radioactive material to decay to half of its original strength is referred to as the *half-life*. The half-life of the Am-241:Be source is 432 years. The half-life of the Cs-137 source is 30 years.

The *Source Decay* feature allows the operator to view how the decrease in the radiation intensity of the source affects gauge measurements. It displays the actual standard count, the predicted standard count, and the error between the two sets of counts. The gauge calculates the predicted standard count by correcting the calibration standard count for source decay.

To access the *Source Decay* feature, press the **<SPECIAL>** key. At the *Special* functions menu, access the *Gauge Status/Test* menu by pressing **<2>**. At the *Gauge Status/Test* menu, press **<6>** *Source Decay*.

**Current D1 Std:xxxx
Predict D1 Std:xxxx
% Difference: xx.x%
Press ENTER**

To scroll through the displays, press the **<ENTER>** key. After displaying all the displays, the gauge returns to the *Ready* screen.

TROUBLESHOOTING

GAUGE FAILS STANDARD COUNTS

- ✓ Ensure the source rod opening on the bottom of the gauge is completely closed or covered by the tungsten sliding block. If any opening is visible, the sliding block should be cleaned. Refer to page A-11 for instructions. If the sliding block still does not close completely, contact the nearest Troxler Service Center.
- ✓ Ensure that the standard count site is asphalt, concrete, or compacted soil at least 4 in. (10 cm) thick.
- ✓ Check for 10 ft (3 m) clearance around gauge.
- ✓ Check that any sources are at least 33 ft (10 m) away.
- ✓ Ensure the source rod handle is fully latched in the **SAFE** (shielded) position.
- ✓ Check that the gauge is positioned correctly on the reference standard block (see Figure 4-1 on page 4-3).
- ✓ Perform the standard count again. If the standard count still fails, contact the nearest Troxler Service Center.

NO DENSITY READINGS

- ✓ The most likely reason for no density readings is an electronic problem, such as a failure of the detector preamplifier. However, there is a remote possibility that the radioactive source could have become dislodged or lost. Refer to the *Source Rod Inspection* section on page A-9 for instructions on inspecting the source rod.

GAUGE READINGS APPEAR ERRATIC

- ✓ If taking readings in the backscatter position, ensure the source rod is properly locked in the notch and not resting on the test material.
- ✓ Check the inside of the gauge for moisture. To dry the gauge interior, remove the keypad. If necessary, use a hair dryer (on low heat) to circulate warm air for one to three hours.
- ✓ Remove any foreign objects from inside the gauge.
- ✓ Ensure the hardware mounting screws are tight and in place.
- ✓ Check count time – a four-minute count will give the highest precision, with a repeatability of ± 1 pcf on repeated tests performed without moving the gauge.
- ✓ Erratic density readings may be caused by a dirty tungsten sliding block. Clean the sliding block (see page A-11).
- ✓ Perform a stat test:
 - ▶ If test passes, proceed with job.
 - ▶ If test fails, repeat two more times. If test fails two out of three times, contact the nearest Troxler Service Center.

GAUGE WILL NOT COMMUNICATE WITH PRINTER OR COMPUTER

- ✓ Check that the correct cable is being used.
- ✓ Ensure that the gauge and printer/computer baud rates are the same (see page 3-13).
- ✓ Ensure that all other parameters match:
 - ◆ Data bits = 8
 - ◆ Stop bits = 2
 - ◆ Parity = none
 - ◆ Protocol = DSR/DTR

SOFTWARE LOCKS UP

- ✓ To turn the gauge off, press and hold the **<ON>** key for five seconds or more, then release.
- ✓ Check the inside of the gauge for moisture. To dry the gauge interior, remove the keypad. If necessary, use a hair dryer (on low heat) to circulate warm air for one to three hours.
- ✓ Remove any foreign objects from inside the gauge.
- ✓ The scaler (control unit) may be defective. To test, replace the suspect (control unit) scaler with a good scaler.

GARBAGE OR XXXXXX IS DISPLAYED

- ✓ If a value exceeds the display area, the gauge will display **++++**.
- ✓ Check the standard counts in memory. If the standard counts are suspect, perform new standard counts. If counts equal zero for both systems, the high voltage board must be replaced (contact the nearest Troxler Service Center).
- ✓ Check gauge for water damage. If the gauge is wet, dry the gauge interior with hair dryer (on low heat) for 3 hours.
- ✓ Check that the calibration constants are valid.
- ✓ Ensure that the measurement depth displayed by the gauge corresponds to the actual source rod depth.

GAUGE TURNS OFF AFTER IT IS TURNED ON

- ✓ To conserve power, the Model 3450 provides a sleep mode (see page 3–17). To turn the display on in the sleep mode, press any key.
- ✓ The gauge may be wet. **Do not turn the gauge on until moisture is removed from gauge interior! Component damage may result.** If the gauge is wet, dry the gauge interior with hair dryer (on low heat) for 3 hours.
- ✓ Replace the alkaline batteries.
- ✓ If the rechargeable battery is below 4 volts, recharge or replace the batteries (see page C–20).
- ✓ The scaler (control unit) may be defective. To test, replace the suspect scaler with a good scaler.

SHORT BATTERY LIFE AFTER RECHARGING

- ✓ NiCad batteries may be charged up to 100 or 500 or more full charge/discharge cycles. The batteries may be reaching the end of their life cycle, and should be replaced.
- ✓ Charger/adaptor may not be supplying full charge – check the ac outlet and the dc output (12 V dc) using a voltmeter on the proper setting.
- ✓ Check that you are using the correct charger.
- ✓ Remove any loose screws or foreign objects from the gauge interior that may cause an electrical short to ground.
- ✓ The ac charger may be defective. To check, use the dc adapter to charge the batteries.

SATISFACTORY COUNTS BUT RESULTS ARE IN ERROR

- ✓ Ensure that the measurement depth displayed by the gauge corresponds to the actual source rod depth.
- ✓ Check that the calibration constants are valid.
- ✓ Check to see if an offset (density, moisture, trench or special) is enabled.
- ✓ Ensure the standard counts are correct.

BACKLIGHT WILL NOT OPERATE

- ✓ NiCad batteries may be discharged. Backlight will not operate on alkaline batteries. Recharge NiCad batteries.

ERROR MESSAGES

BATTERIES TOO LOW! GAUGE IS TURNING OFF IN XXX SECONDS

This error occurs when the following three items are **all true**: the charger is not connected, the NiCad batteries are low, and the alkaline batteries need replacing.

Solution: Charge the NiCad batteries and replace the alkaline batteries.

DIVIDE BY ZERO ERROR!

This error occurs when attempting to perform division by zero.

Solution: Check for incorrect measurement depth, calibration constants, standard count, counts, offsets, and special calibrations. Identify and correct the problem.

ERROR! BASEBOARD NOT CONNECTED

This error occurs when the control unit does not detect a base unit.

Solution: Unscrew the four captive screws on the control panel and make sure the ribbon cable connecting the control unit with the base unit is seated properly.

ERROR! GAUGE MUST BE IN THIN LAYER MODE

This error occurs when attempting to enable a thin layer special calibration when in *Soil* or *Asphalt* mode.

Solution: To enable a thin layer special calibration, change to the *Thin Layer* mode. To enable special calibration in *Soil* or *Asphalt* mode, select the special calibration for the selected mode.

ERROR! INCORRECT BASEBOARD ID

This error occurs if the ID stored in the base unit does not match the ID stored in the control unit.

Solution: Make sure the control unit is the correct unit for a particular base unit.

INVALID DEPTH – CHECK SOURCE ROD

This error occurs when the source rod is not at a valid depth when starting a measurement.

Solution: Check source rod position to ensure it is at a valid depth when starting a measurement. Recalibrate depth strip. Call the nearest Troxler Service Center.

KEYPAD ERROR!

This error is reported after the power-up self-test if a stuck key is detected.

Solution: Clear the keypad of any objects pressing keys on powerup.

LCD ERROR!

During the Liquid Crystal Display (LCD) test, a sequence of characters is written to the LCD and is then read back. This message occurs if a character read back does not match the character written out.

Solution: Call the nearest Troxler Service Center.

MEMORY ERROR!

This error occurs when gauge software detects that non-volatile memory has been corrupted.

Solution: Call the nearest Troxler Service Center.

NO ACTIVE PROJECT

This error occurs when trying to store measurement data in a project without a project selected.

Solution: Select an existing project or create a new project and select.

NO DATA TO PRINT

This error occurs when attempting to print a project with no data.

Solution: Be sure to select the correct project when attempting to print.

PROJECT XXXXXXXXXXXX HAS NO DATA

This error occurs when attempting to view a project with no data.

Solution: Be sure to select the correct project when attempting to view.

REPLACE BATTERIES!

This error occurs when the alkaline batteries need replacing.

Solution: Charge the NiCad batteries and replace the alkaline batteries.

SERIAL DEVICE NOT CONNECTED!

This error occurs when the serial input signals from printing device are incorrect.

Solution: Check for correct serial cable. Printer must be on line. (Serial printer only.)

SYSTEM ERROR! SYSTEM DATA MAY BE LOST

This error occurs when the software system variables have been corrupted.

Solution: The software attempts to correct the problem, but gauge setup may be lost. If problems continue to occur, call the nearest Troxler Service Center.

WARNING! LEAK TEST IS DUE. LAST LEAK TEST DATE: XX/XX/XXXX

This error occurs when the leak test interval (default: 6 months) has elapsed since the last reset of the leak test date.

Solution: Perform a leak test and reset the leak test date to current date.

WARNING! SOURCE ROD NOT AT BS

This error occurs when the software expects the source rod to be at a particular position and detects that it is not.

Solution: Check source rod position to ensure it is at the proper position. Recalibrate depth strip. Call the nearest Troxler Service Center.

BATTERIES

The Model 3450 is equipped with three sets of batteries: one set of NiCad batteries (pack of four Sub-C batteries), and two sets of AA alkaline batteries. Each set of alkaline batteries contains three batteries. All six alkaline batteries should be replaced together.

NOTE

Do not remove the alkaline batteries for more than one hour. Do not attempt to operate the gauge with the alkaline batteries removed. Loss of all project, setup, and calibration data may result. Change the NiCad and alkaline batteries separately to prevent data loss.

The primary batteries are the rechargeable NiCad batteries. Under standard conditions, fully charged NiCad batteries can power the gauge for about four weeks of average operation (150 one-minute readings per week). Standard conditions assume that the operator does not use the backlight or external beeper, and that the sleep mode is set to 30 seconds.

The alkaline batteries provide backup for the NiCad batteries and RAM. Under average operating conditions, the six alkaline batteries should be replaced yearly.

When the NiCad batteries drop below 4 V, the gauge switches to the alkaline batteries. The operator can finish the day's measurements, then recharge the NiCad batteries. In fact, the alkaline batteries can power the gauge for about ten weeks of average operation. However, Troxler recommends that the operator recharge the NiCad batteries and use the alkaline batteries only as a backup. The NiCad batteries can be fully recharged in only four hours. Note that the backlight will not operate when the gauge is powered by the alkaline batteries.

BATTERY STATUS

The *Battery Status* option displays the charge status of the NiCad batteries and the voltage of the NiCad and alkaline batteries. The *Battery Status* option is a *Special* function under *Gauge Setup*. To access the *Gauge Setup* menu, press the **<SPECIAL>** key, then press **<4>**.

- | |
|---|
| <p>1- Set Time/Date
 2- Print Set-Up
 3- Depth Indicator
 4- Set Beeper Level</p> |
|---|

To scroll through the *Gauge Setup* menu, use the arrow keys. To select *Battery Status*, press **<7>**.

<p>Chgr: 0.0V- OFF Nicad: 4.5V- In Use Alk 1: 4.3V- Ready Alk 2: 4.5V- Ready</p>

The first line shows the NiCad charger voltage and status. The second line shows the NiCad battery voltage and status. The third and fourth lines show the voltage and status for the two sets of alkaline batteries. The minimum requirements for battery operation are as follows:

	<u>Minimum</u>
NiCad batteries	4.0 V
Alkaline batteries 1 (ALK1)	3.0 V
Alkaline batteries 2 (ALK2)	3.5 V

If the NiCad batteries are below their minimum voltage, re-charge them. If either ALK1 or ALK2 is below its minimum voltage, replace both sets of batteries.

Return to the *Gauge Setup* menu by pressing the **<ENTER>** key. Return to the *Ready* screen by pressing the **<ESC>** key.

CHARGING

To charge the NiCad batteries, plug the charger into the round jack on the back of the gauge. Plug the other end of the ac charger into a standard 110 V ac outlet. For the international charger, 220 V ac may be used. For the European charger, 100-240 V ac may be used. The dc adapter may be connected to any 12-14 V dc source (such as a vehicle's cigarette lighter). To ensure a full charge, charge the batteries for four hours.

After recharging the batteries, unplug the charger from both the wall outlet and the gauge. Store the charger for later use.

REPLACING THE BATTERIES

To replace the alkaline batteries:

- ✓ Turn the gauge off.
- ✓ Loosen the four captive screws on the keypad assembly.
- ✓ Carefully lift the keypad assembly from the gauge.
- ✓ Unplug the ribbon cable from the keypad assembly.
- ✓ Place the keypad assembly face down.
- ✓ Remove the four screws from the 4 × 2-inch black cover on the back of the keypad assembly. Set the screws aside.
- ✓ Remove the black cover.
- ✓ Replace the batteries with six standard AA alkaline batteries (three at a time to prevent data loss).
- ✓ Replace the black cover.
- ✓ Secure the black cover to the keypad assembly with the four screws.
- ✓ Plug the ribbon cable into the keypad assembly.
- ✓ Attach the keypad assembly to the gauge with the four captive screws.

To replace the NiCad battery pack:

- ✓ Turn the gauge off.
- ✓ Unscrew the four captive screws on the keypad assembly.
- ✓ Carefully lift the keypad assembly from the gauge.
- ✓ Unplug the ribbon cable from the keypad assembly.
- ✓ Place the keypad assembly face down.
- ✓ Unplug the 6-pin connector from the NiCad battery pack (see Figure C-1). Gently squeeze the connector.
- ✓ Lock the battery pack retaining pin into the disengaged position by pulling and twisting the knob on the pin.
- ✓ Slide the NiCad battery pack out of the gauge.
- ✓ Slide a new NiCad battery pack into the gauge.
- ✓ Engage the battery pack retaining pin by pulling and twisting the knob on the pin.
- ✓ Plug the 6-pin connector into the NiCad battery pack.
- ✓ Re-assemble the gauge.

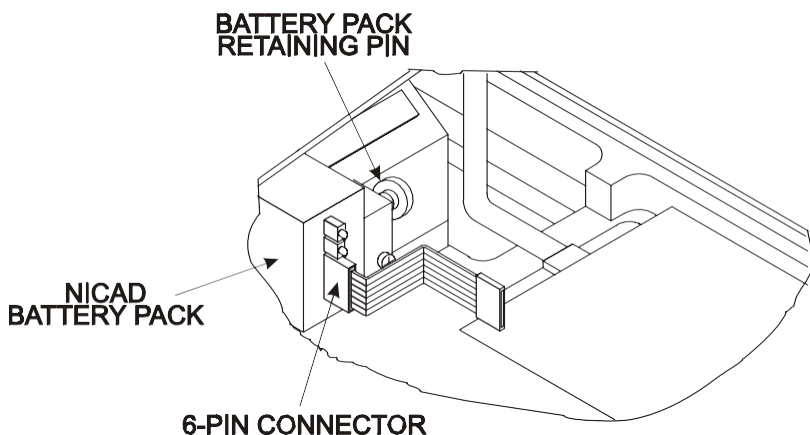

Figure C-1. Replacing NiCad Battery Pack

MECHANICAL MAINTENANCE



CAUTION – EUROPEAN COUNTRIES –

Do not separate the control unit from the base. Doing so will result in non-compliance with EMC directive. Call your Troxler representative for additional information.

CLEANING THE BASE AND TOP SHELL

To clean the gauge base, use a putty knife to scrape away any built-up accumulations of soil or asphalt. **Be careful not to damage the gauge base!** After removing any large accumulations, wipe the gauge base with a cloth soaked in WD-40→ (see note below). The WD-40 should remove the remaining debris.

CAUTION

WD-40 can damage the keypad. Do not allow WD-40 to come in contact with the keypad! The keypad may be cleaned using a mild soap (such as 409□ or Fantastic□), followed by clean water.

The 3450 gauge top shell is manufactured from an engineering thermoplastic designed specifically to provide high impact strength and to offer excellent compatibility with many industrial solvents and petro-chemicals. The top shell may be cleaned with mild (low alkaline) soap and water. Other approved cleaning substances include: methyl, isopropyl, or isobutyl alcohols. A cloth dampened with kerosene or diesel fuel may be used to remove heavy soils. **Avoid prolonged exposure and do not soak.**



CAUTION

The use of any unapproved cleaning agents such as methyl-ethyl-ketones, amines, and methylene chloride will damage the top shell and void the warranty.

LUBRICATING THE SOURCE ROD

If the source rod does not slide up and down freely, the source rod bearing may require lubrication.



CAUTION
– EUROPEAN COUNTRIES –
Do not operate the control unit separate from the base. Doing so will result in non-compliance with EMC directive. Call your Troxler representative for additional information.

- ✓ Remove the control unit from the gauge by loosening the four captive screws that secure the control unit to the top shell. Lift the control unit out of the gauge and disconnect the ribbon cable.
- ✓ Using a 9/64-inch Allen wrench, remove the six screws that hold the top shell to the gauge base.
- ✓ Clean the screws and set them aside.
- ✓ Carefully remove the gauge top shell and slide it up, out of the way. To keep it out of the way, tie the top shell to the handle.
- ✓ To catch any grease, place a rag or cloth under the vent valve located below the grease fitting on the source rod tower.
- ✓ Using a standard 16-oz grease gun loaded with a Magnalube→-G cartridge, apply five shots of lubricant or until all dirty grease is ejected from the vent valve and clean grease is visible.

NOTE

The vent valve was not installed on earlier gauges. Instead, an Allen-head screw was located below the grease fitting. On these gauges, remove the Allen-head screw before applying lubricant to allow the old grease to be ejected. Failure to remove this screw may result in severe mechanical damage to the base assembly.

- ✓ Re-assemble the gauge.

REPLACING GASKETS

The Model 3450 employs two gaskets and an o-ring to protect its electronics from moisture, dirt, and debris. However, if the gauge has been exposed to extremely wet weather or high humidity, or if the gauge was used in the cold and stored in a warm building, condensation may form inside the gauge. If this happens the top shell should be removed and the gauge allowed to dry. Use a hair dryer (on low heat) if necessary to remove any built-up moisture. If moisture continues to be a problem or debris is present inside the gauge base, the gaskets or o-ring may need replacing.

To replace the control panel gasket, loosen the four captive screws that attach the control unit (keypad) to the top shell. Carefully lift the control unit from the top shell and detach the ribbon cable.

Gently peel the old gasket from the panel and replace it with a new gasket. Reconnect the ribbon cable and reinstall the control unit.

To replace the top shell/base o-ring, remove the control unit as described above, then remove the screws that hold the top shell to the gauge base. Lift the top shell from the gauge base. Remove the o-ring from the gauge base. Coat the replacement o-ring with vacuum grease. Install the new o-ring in the groove on the base. Replace the top shell and tighten the top shell screws.

The auxiliary panel gasket should never need to be replaced. To replace this gasket, remove the screws that hold the top shell to the gauge base. Lift the top shell from the gauge base. Remove the screws that secure the auxiliary gasket to the backing plate. **Gently** peel the old gasket from the plate and replace it with a new gasket. Re-assemble the top shell and gauge base.

LEAK TESTING

To ensure the integrity of the radioactive source encapsulation, the Model 3450 must be periodically leak tested. For instructions on performing the leak test, see page A-13.

LEAK TEST DATE

The *Leak Test* function allows the operator to enter the date of the last leak test. The gauge alerts the operator if the *leak test interval* has been exceeded.

By default, the leak test interval is set to six months, as required by U.S. regulations. In countries outside of the United States, the time required between leak tests may vary from six months to three years. Check local regulations, then refer to page C-26 for instructions on setting the leak test interval.

Until a current leak test date is entered, the gauge displays an alert after the self-test at power up. Update the leak test date in the gauge after each leak test.

NOTE

The *Leak Test* function does not replace the leak test analysis records that must be maintained for review by your licensing agency.

To view or change the leak test date displayed by the gauge, press the **<SPECIAL>** key. At the *Special* functions menu, press **<2>** to access the *Gauge Status/Test* menu. At the *Gauge Status/Test* menu, press **<5>**.

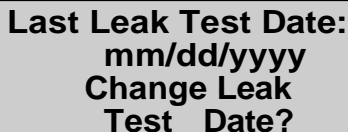

**Last Leak Test Date:
mm/dd/yyyy
Change Leak
Test Date?**

The gauge displays the date entered for the last leak test. To return to the *Ready* screen, press the **<NO>** key. To change the leak test date, press the **<YES>** key.

**Input Leak Test Date
mm/dd/yyyy
Change Leak
Test Date?**

The gauge displays mm/dd/yy on the second line. To enter a date for the most recent leak test for this gauge, use the numeric keys. When the second line displays the most recent leak test for this gauge, press the **<ENTER>** key. The gauge updates the leak test date and returns to the *Ready* screen.

LEAK TEST INTERVAL

The leak test interval and leak test date values are used to alert the operator when a leak test is due. To change the leak test interval, press the **<SPECIAL>** key. Press **<4>** *Gauge Setup*. Use the arrow keys to scroll down to the following display:

**9- Customer Name
.0- Change User Code
.1- Leak Test
Press ESC To Exit**

Press **<.>** then **<1>** *Leak Test*. The gauge displays:

**Leak Test Interval
XXX Days
Input # of Days
Then Press ENTER**

The default value for the leak test interval is 183 days (six months). Enter the desired number of days and press **<ENTER>**. The gauge returns to the *Gauge Setup* menu. Press **<ESC>** to return to the *Ready* mode.

DISPLAY CONTRAST

The gauge display may be difficult to read when viewed in bright light. If so, adjust the display contrast as follows:

- ✓ Loosen the four captive screws located in the corners of the keypad.
- ✓ Gently lift the control unit from the gauge and place it to the right side of the gauge.
- ✓ An adjustment potentiometer for the display contrast is located inside an access hole in the top edge of the control unit, as shown in Figure C-2.
- ✓ Using a small screwdriver, adjust the potentiometer to obtain the desired display contrast.
- ✓ Gently place the control unit inside the gauge and tighten the four captive screws in the corners of the keypad.

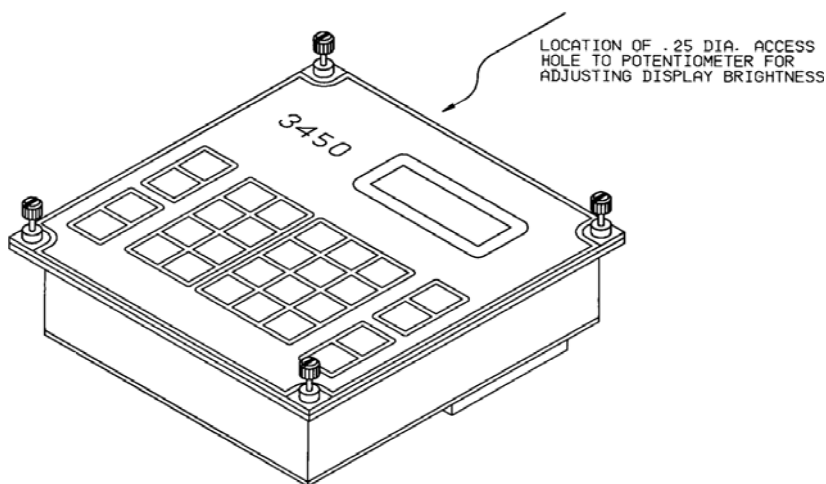

Figure C-2. Display Contrast Adjustment

REPLACEMENT PARTS

<u>PART #</u>	<u>DESCRIPTION</u>
107279	Gasket Front Panel
107849	O-Ring, Gauge Base
107831	Gasket, Auxiliary Panel
107846	Gasket, Beeper
107233	Grommet, Tower Index Rod
107278	3450 Topshell
107800	Assembly, 3450 Front Panel
107275	Overlay, 3450
108531	Assembly, I/O Baseboard Cable
107847	Base Plate Assembly
107276	3450 Bottom Plate
012754	Ring Scraper (for Bottom Plate)
012753	Ring Retaining (for Scraper Ring)
013200	Fitting, 3/16 Grease w/ Serrated Shank
107493	3450 Sliding Block
107494	Fixed Tungsten Block
102069.1000	2400/3400 Wiper Cap
012752	Seal, Wiper
012759	Seal, Oil 5/8-inch ID
102399	Shield Spring 3400
108866	Source Rod Bearing
012176	Lock w/ 2 Keys (Handle)
107835	Handle Assembly
104305	Handle Sleeve
108865	Trigger
012225	Spring (For Trigger)
102096	3400 Cap Screw
102103	Cap Screw Bumper
104553	Plunger 3400
101603.1010	Roll Pin, 3/32 D × 5/8 L (Index Rod Top)
012775	Battery Spring Plunger
107990	Cable, NiCad Battery
107820	Assembly, 3450 NiCad Battery
100156	5/8-inch Tube GM (Detector)
105062	3/4-inch GM Tube (Detector)
104094.0001	900 V dc Moisture Tube Assembly
108863	Bioshield w/ Bearing

ACCESSORIES

<u>PART #</u>	<u>DESCRIPTION</u>
107839.3450	3450 Shipping Case/Carton Assembly
100421	Forged Drill Rod
107795	Scraper Plate Weldment
103680.1000	Extraction Tool
107830	Reference Standard Block Assembly
110403	AC Adapter, 12 V CE
104156	DC Charger
107837	3450 User Manual
107900	3450 Quick Reference Guide

OPTIONS

<u>PART #</u>	<u>DESCRIPTION</u>
104661.3000	Printer Package 3450
107768.0006	Printer Cable
104340	3440 (3450) Printer
104341	3440 (3450) Printer Battery Pack
106514.0002	Serial Cable Assembly
107480	3450 Concrete Adapter
021140	Radiation Sign Kit
102868	3880 Leak Test Kit w/4 Packets
102873	1-oz Solution Detergent
102876.0005	Leak Test Packet (4 units)
109661	Survey Meter
105817	Kit, Emergency Response

MAINTENANCE SUPPLIES

<u>PART #</u>	<u>DESCRIPTION</u>
012784	Lubricant Magnalube-G Paste 1.5 oz
012786	Lubricant Magnalube-G Paste 1 lb Can
012789	Lubricant Magnalube-G 14.5 oz
100761	Source Rod Pig

RETURNING THE GAUGE FOR SERVICE

All shipments within the United States to the factory must be accompanied by an RGA (Returned Goods Authorization) number, and a description of the instrument and its problem. This information is used by Troxler shipping and service personnel to expedite the repair work.

To obtain an RGA number, please call or fax the factory or branch office with your request. Please have the following information available when contacting Troxler for an RGA number:

- ◆ Gauge model and serial number.
- ◆ Part number/serial number (if applicable).
- ◆ Is the gauge still under warranty?
- ◆ Problem or difficulty you are having with the instrument.
- ◆ Shipment method to Troxler and for return shipment.
- ◆ Shipping and billing address (not P.O. Box) – street address and zip code.
- ◆ Telephone number and contact (for questions from Troxler).
- ◆ Will estimate be required before performing any work on the gauge?
- ◆ Payment method: credit card, account number, or purchase order number. All U.S. government agencies (city, county, state and federal) must send purchase order numbers.

NOTE

To prevent order duplication, if an order has been placed by telephone, please write “Confirming Order” on any follow-up written requests.

NOTE

When returning a 3450 gauge, follow the required special handling and shipping procedures detailed in Appendix D. Please contact a Troxler Sales Support or Service Representative with any questions.

APPENDIX D

TRANSPORTATION AND SHIPPING

Devices containing radioactive materials must be transported in accordance with the rules of the U.S. Department of Transportation (DOT) and the International Atomic Energy Agency (IAEA). The IAEA recommendations have been codified in the International Air Transport Association (IATA) Dangerous Goods Regulations. International customers should consult their local government or licensing authority for applicable regulations.

CONTENTS

U.S. Shipping Requirements.....	D-2
Accident Notification Requirements.....	D-3
Hazmat Training.....	D-3
Canadian Shipping Requirements.....	D-4

U.S. SHIPPING REQUIREMENTS

The U.S. DOT hazmat regulations (49 CFR, Parts 100–185) apply any time a nuclear device is transported by motor vehicle on a public highway or by other means of transport (rail, air, ship).

The major requirements for transporting a nuclear gauge in the United States are listed below. For more detailed information about these requirements, please refer to the *Troxler Transportation Guide*.

- ◆ A copy of the current IAEA Certificate of Competent Authority for each source in the gauge (Special Form Certificate) must be kept on file. Current versions can be downloaded from the Troxler website, www.troxlerlabs.com.
- ◆ A copy of the results of the Type A package testing must be kept on file.
- ◆ Hazmat employee training records must be kept on file.
- ◆ An *Emergency Response Information* document must be in the vehicle and immediately accessible to the driver.
- ◆ A properly completed bill of lading must be in the vehicle and immediately accessible to the driver. The shipping papers must include a 24-hr emergency response phone number.
- ◆ If shipping by air, a *Shipper's Declaration for Dangerous Goods* must accompany the air waybill.
- ◆ The package must be properly marked and labeled in accordance with hazmat regulations.
- ◆ The package must have a tamper-evident seal.
- ◆ The package must be inspected prior to each shipment.
- ◆ The package must be securely blocked and braced in the vehicle to prevent shifting during transport.

ACCIDENT NOTIFICATION REQUIREMENTS

In the event of a reportable incident involving radioactive material, notify the licensing agency as soon as practical. The operator is also required to notify, at the earliest practical moment, the U.S. DOT at 1-800-424-8802 of an accident that occurs during the course of transportation (including loading, unloading, and temporary storage) in which fire, breakage, spillage, or suspected contamination occurs involving shipment of radioactive materials.

HAZMAT TRAINING

The U.S. DOT regulations require every hazmat employer to train, test, certify, and maintain records for each hazmat employee. Hazmat training applies to anyone who transports or prepares for transport radioactive materials. To remain in compliance with this requirement, training must be repeated every two years (IATA requirement) if the gauge is shipped by air (for example, by Federal Express→) or every three years (U.S. DOT requirement) if shipped by ground transportation.

CANADIAN SHIPPING REQUIREMENTS

The *Transportation of Dangerous Goods Act and Regulations* (TDG) and *Transport Packaging of Radioactive Materials Regulations* (TPRM) apply any time a nuclear device used in commerce is transported by any means in Canada.

For training and accident notification requirements, consult the *Transportation Of Dangerous Goods Regulations*. For further information on transporting a nuclear device, contact the transportation section of The Canadian Nuclear Safety Commission (CNSC).

APPENDIX E
STANDARD COUNT LOG

Use the form in this appendix as a guide when recording the daily standard counts. To verify gauge stability, compare the daily standard count to the average of the last four recorded standard counts.

STANDARD COUNT LOG

Gauge Serial Number _____

Date	Moisture (MS)	Density (DS1)	Density (DS2)

STANDARD COUNT LOG

Gauge Serial Number _____

Date	Moisture (MS)	Density (DS1)	Density (DS2)

E. STANDARD COUNT LOG

STANDARD COUNT LOG

Gauge Serial Number _____

Date	Moisture (MS)	Density (DS1)	Density (DS2)



STANDARD COUNT LOG

Gauge Serial Number _____

Date	Moisture (MS)	Density (DS1)	Density (DS2)

E. STANDARD COUNT LOG

STANDARD COUNT LOG

Gauge Serial Number _____

Date	Moisture (MS)	Density (DS1)	Density (DS2)



STANDARD COUNT LOG

Gauge Serial Number _____

Date	Moisture (MS)	Density (DS1)	Density (DS2)

E. STANDARD COUNT LOG

STANDARD COUNT LOG

Gauge Serial Number _____

Date	Moisture (MS)	Density (DS1)	Density (DS2)

APPENDIX F

UNIT CONVERSION

The Troxler Model 3450 RoadReader Plus can display measurement results in either SI (metric) units or English units. Also, HM-181 of 49 CFR changes the standard units of radioactivity in the United States from the English unit of *curies (Ci)* to the SI unit of *becquerel (Bq)*. This requires the shipper to convert the activity on the Bill of Lading from curies to becquerels (GBq). Until everyone is accustomed to the SI units, it is permitted to follow the SI units with the English units in parentheses to clarify the description [for example: 1.48 GBq (40 mCi)].

To help our users convert from English units to SI units, the table in this appendix provides SI conversion factors for common English units relevant to the 3450 gauge.

CONTENTS

Measurement Units	F-2
Radiological Units	F-2

MEASUREMENT UNITS

1 in. = 25.4 mm

1 in. = 2.54 cm

1 ft = 30.48 cm

1 ft = 0.3048 m

1 pcf = 16.02 kg/m³

1 pcf = 1.6 × 10⁻² g/cm³

RADIOLOGICAL UNITS

1 rem = 0.01 Sv

1 Ci = 37 GBq

1 mCi = 37 MBq

1 μCi = 37 kBq

The following table is provided to assist the operator in converting from millicuries to gigabequerels:

<u>mCi</u>	to	<u>GBq</u>
8.0.....		0.30
40.....		1.48

APPENDIX G

SPECIAL EUROPEAN CONSIDERATIONS

This section applies only to those Troxler Model 3450 RoadReader Plus gauges with the CE mark that are to be used in European countries.

CONTENTS

Declaration of Conformity..... G-2

Safety Warnings..... G-3

DECLARATION OF CONFORMITY

Application of Council EMC Directive 89/336/EEC, 93/42/EEC and Low Voltage Directive 73/23/EEC

Standards to which Conformity is Declared:

EN 61010-1
EN 55011 Group 1, Class A
EN 50082-2

Manufacturer:

Troxler Electronic Laboratories, Inc.
P.O. Box 12057
3008 Cornwallis Road
Research Triangle Park, North Carolina
27709
USA

Apparatus:

Model 3450 RoadReader Plus
Surface Moisture-Density Gauge

Year of Declaration:

2002

Responsible Person:

Roland A. Hohlrieder
Prokurist
Troxler Electronics GmbH
Wholly Owned Subsidiary
Gilchinger Strasse 33
D-82239 Alling
Germany
Telephone: 011 49 81 41 71063
FAX: 011 49 81 41 80731



SAFETY WARNINGS

Owners are encouraged to require study of this manual before allowing anyone to use the gauge. **A potential hazard does exist if improperly used.** The sections of the manual covering radiological safety should be required reading for all users and potential users. **If these sections are not completely understood, users should seek assistance from Troxler, an appointed Troxler representative, or others designated within the user's organization.**

The following list of safety warnings applies to gauges with the CE mark and that are to be used in European countries. In addition to these safety warnings, all other safety warnings and cautions throughout this manual apply to gauges with the CE mark.

- ◆ There are no user-serviceable parts — only qualified service personnel should remove shields or covers to attempt repairs.
- ◆ Do not remove any shields or covers. A high-voltage hazard is located under the baseboard cover.
- ◆ The dc adapter shall be used on properly fused vehicle cigarette lighters only.
- ◆ Do not separate the control unit from the base. This will result in non-compliance with the EMC directive.
- ◆ European countries shall use a proper IEC input cord to the European charger (specified by local laws and practices).
- ◆ Do not throw batteries into fires. There is a risk of explosion.
- ◆ Use caution when lifting, moving, and/or carrying the gauge — it is heavy.
- ◆ See Appendix A for radiation safety instructions.

NOTES

APPENDIX H

PRINTING (UPLOADING) PROJECT DATA

Current versions of Microsoft→ Windows→ (Windows 95 and later) include a *HyperTerminal* communications program that can be used to transfer project data from the Model 3450 RoadReader Plus to a computer. This appendix provides instructions on using the *HyperTerminal* program to print (upload) data from the gauge.

CONTENTS

Windows Hyperterminal.....	H-2
HyperTerminal Setup	H-2
Equipment Connection.....	H-3
Printing (Uploading) Project Data.....	H-3
Viewing Project Data.....	H-5

WINDOWS HYPERTERMINAL

To print (upload) data from the gauge to a computer equipped with a Microsoft Windows operating system, use the *HyperTerminal* program as described in the following sections.

HYPERTERMINAL SETUP

To configure the Windows *HyperTerminal* program and set up a dedicated icon to transfer data from the gauge, perform the following steps:

1. Click on the **Start** button, select the **Programs** menu, and then the **Accessories** folder.
 - ▶ In Windows 95, select the **HyperTerminal** icon.
 - ▶ In Windows 98 and later versions, select the **Communications** subfolder, and then select the **HyperTerminal** icon.
2. From the **HyperTerminal** window, double-click on the **Hypertrm** icon. The **Connection Description** window is displayed. This window is used to set up a new connection.
3. In the **Name** box, enter a name (for example, *Troxler Data*) for the new connection. Select an icon to use for the connection, then click **OK**. The **Connect To** window is displayed.
4. In the **Connect To** window, *do not* enter a telephone number. Instead, select **Direct to Com1**, **Direct to Com2**, **Direct to Com3**, or **Direct to Com4**, depending upon the computer. The **COM# Properties** window is displayed, where # is the number of the selected COM port.
5. Configure the **Port Settings** as follows:

Bits per second	9600
Data bits	8
Parity	None
Stop bits	1
Flow control	Hardware

6. Click **OK**. The **Troxler Data – HyperTerminal** window is displayed, where *Troxler Data* is the icon name entered in step 3.
7. From the toolbar, click on **F**ile and select **S**ave from the dropdown menu.
8. Close the **Troxler Data – HyperTerminal** window by selecting **E**xit from the **F**ile menu.

EQUIPMENT CONNECTION

Connect the gauge to the computer using the appropriate serial cable (see the list of *Accessories* on page C-29). Connect the gauge's serial port (see Figure 3-1 on page 3-2) to the computer COM port selected in step 4 of the *HyperTerminal Setup* section on the previous page.

PRINTING (UPLOADING) PROJECT DATA

To print (upload) project data from the gauge to the computer:

1. On the computer, click on the **S**tart button, then select the **P**rograms menu and the **A**ccessories folder.
 - ▶ In Windows 95, select the **H**yperTerminal icon.
 - ▶ In Windows 98 and later versions, select the **C**ommunications subfolder, then select the **H**yperTerminal icon.
2. From the **H**yperTerminal window, double-click on the **Troxler Data – HyperTerminal** icon (where *Troxler Data* is the icon name entered in the *HyperTerminal Setup* section on the previous page). The **Troxler Data – HyperTerminal** window is displayed.

3. From the toolbar, click **T**ransfer, then select **C**apture Text from the dropdown menu. The **Capture Text** window is displayed, showing a default folder and filename to be used to store the data. Troxler recommends using the default settings when first using the program. After selecting a filename, click **S**tart to enable data capture.
4. On the gauge, select the project data to be printed (uploaded) to the computer, and follow the instructions in Chapter 5 to print the data to the computer. The project data will be displayed in the **Troxler Data – HyperTerminal** window as it is uploaded.
5. When the data transmission is complete, select **T**ransfer from the toolbar. Then select **C**apture Text and **S**top from the dropdown submenu.
6. Exit the *HyperTerminal* program.

VIEWING PROJECT DATA

After project data has been printed (uploaded) to the computer, the *.txt* file can be viewed using Microsoft Notepad or a word processing program, such as Microsoft Word→.

The data can also be imported into an Excel spreadsheet, which can then be used to manipulate and manage the data. To import the data into an Excel spreadsheet:

1. Open the Excel program.
2. From the Excel toolbar, click **Data**, then select **Get External Data** and **Import Text File**. The **Import Text File** window is displayed.
3. Select the file that was saved when data was downloaded using the *Hyperterminal* program, then click **Import**. The **Text Import Wizard** is displayed.
4. In step 1 of the **Text Import Wizard**, check the **Delimited** radio button, then click **Next**. In step 2 of the wizard, select only the **Comma** checkbox, then click **Next**. In step 3, select the **General** radio button, then click **Finish**. The **Import Data** window is displayed.
5. Check the **Existing worksheet** radio button, then click **OK** to import the data.

NOTES

INDEX

A

AC charger.....	1-5
Access code	xi
Accessories	1-4, C-29
Accident notification.....	D-3
Accuracy	2-6, 4-2
Adapter, dc.....	1-5
Air voids	3-27
Alkaline batteries	C-20, C-19
Alpha particles	A-4
American Society of Testing and Materials (ASTM) standards ...	1-2
Americium-241:beryllium (Am-241:Be).....	2-3
Arrow keys.....	3-4
Asphalt	
Mode setup.....	3-23
Mode specifications	B-2
Site preparation.....	4-8
Taking measurements	4-12
Atomic structure	A-2
Automatic	
Depth mode.....	3-14
Shutdown	B-6

B

Backlight.....	3-15
Backscatter position.....	2-2, 3-5
Battery.....	C-18
Charge.....	C-20, C-14, B-6
Replace alkaline.....	C-20
Replace NiCad	C-21
Specifications.....	B-6
Status.....	3-17, C-19
Baud rate.....	3-13
Beeper level	3-15
Beta particles	A-4

C

Cable pinouts	B-7
Calibration	2-6
Density	6-11
Depth indicator	3-14
Moisture	6-4
Offset	6-2
Special	6-11
Thin layer	6-16
Trench	6-9
Wet density	6-3
Canadian Nuclear Safety Commission (CNSC)	1-3, D-4, A-15
Canadian shipping requirements	D-4
CE key	3-3
Cesium-137 (Cs-137)	2-2
Charge batteries	C-20
Charger, ac	1-5
Cleaning	
Base and top shell	C-22
Tungsten blocks	A-11
Code of Federal Regulations (CFR)	1-3
Communication protocol	3-13
Concrete	
Site preparation	4-8
Taking measurements	4-12
Connections, output device	3-13
Contrast, display	C-27
Control unit, separating	5-2
Convert units	F-1
Count time	3-19
Create project	5-6
Current status	3-9
Customer name	3-18

D

Data	
Erase	5-9
Print/upload.....	5-7
Project.....	5-5
Store.....	5-10
Transmission rate (baud rate).....	3-13
View.....	5-7
Date.....	3-12
Leak test.....	C-25
DC adapter.....	1-5
Decimal key.....	3-4
Declaration of Conformity.....	1-3, G-2
Density.....	2-2, 2-6, 4-10, 4-12, 4-14
Special calibration.....	6-11
Department of Transportation (DOT).....	D-1
Depth	
Indicator.....	3-14
Mode.....	3-14
Of measurement.....	2-3
Detectors.....	1-5, 2-2
Direct transmission.....	2-2, 3-5
Display	
Backlight.....	3-15
Contrast.....	C-27
Specifications.....	B-6
Timeout.....	3-17
Disposal.....	A-16
Drift test.....	C-5
Drill rod.....	1-5, 4-6
Drill rod guide.....	1-5

E

Edit	
Density partial special calibration.....	6-15
Partial moisture offset.....	6-7
Project notes.....	5-11
Target value.....	3-20
Thin layer partial special calibration.....	6-21

Emergency	
Procedures	A-16
Encapsulation	A-8
ENTER key	3-4
Erase	
Density special calibration	6-15
Projects	5-9
Recover	5-9
Thin layer special calibration	6-22
Erratic readings.....	C-10, C-3
ESC key	3-3
European considerations.....	G-1
Exposure, limiting	A-6
Extraction tool	1-5, 4-6

F

Federal Highway Administration (FHWA).....	5-6, 5-10
Flashing red light.....	3-17
Format	
Printout	3-13
Serial data	B-6
Time and date	3-12
Full store.....	5-12

G

Gamma rays.....	B-5, A-4
Gaskets, replacing	C-24
Gauge	
Setup menu	3-10
Temperature.....	B-8
Geiger-Mueller (G-M) tubes	2-2

H

Half-life	C-8
Half-value layer (HVL)	A-7
Hazmat training	D-3
Helium-3 detector.....	2-3
Humidity.....	B-8
HyperTerminal program.....	H-2

I

Inspection	
Daily	3-6, A-10
Source rod	A-9
Upon receipt.....	1-6
International Air Transport Association (IATA)	D-1
International Atomic Energy Agency (IAEA)	D-1

K

K value (moisture offset)	6-4, 6-8
Keypad.....	3-3, B-6

L

Leak test.....	C-25, A-13
Date.....	C-25
Interval.....	C-26
Licensing	1-3, A-15
LIGHT key.....	3-4, 3-15
Liquid crystal display (LCD).....	3-15, B-6
Lubricating source rod.....	C-23

M

Manual	
Depth mode.....	3-14
Display backlight	3-15
Marshall value	3-19
Measurement	
Mode	3-23
Specifications.....	B-2
Memory specifications.....	B-6
Microsoft	
Excel	H-5
Notepad.....	H-5
Windows	H-1
Word	H-5

Mode	
Asphalt.....	3-23, 4-12
Backscatter	2-2
Concrete.....	4-12
Depth	3-14
Direct transmission.....	2-2
Measurement	3-23
Sleep	3-17
Soil	3-23, 4-10
Thin layer	3-23, 4-14
MODE key	3-3
Moisture	2-3, 4-10
Offset.....	2-6, 6-2, 6-4
Monitoring personnel	A-8

N

Neutrons	2-3, B-5, A-4
NiCad batteries	C-19
NiCad battery pack.....	C-21, C-19
NO key	3-4
Number averages.....	3-26
Numeric keys.....	3-4

O

OFF key.....	3-3
Offset.....	2-6
Calibration.....	6-2
Moisture.....	2-6, 6-2, 6-4
Trench.....	2-6, 6-2, 6-9
Wet density.....	2-6, 6-2, 6-3
OFFSET key.....	3-3
ON key	3-3, 3-7
Options	C-29

P

Parts.....	1-4
Replacement	C-28
Percent air voids	3-27
Photons	2-2, A-4
Precautions	A-18

Precision	B-2
Print	
Drift test	C-7
Project data	5-7, H-3
QA sample locations	3-26
Stat test	C-4
Printer	1-5
Cable	1-5
Cable pinout	B-7
Connections	3-13
Setup	3-13
Proctor value	3-19
Profile, radiation	A-19
Project	
Create	5-6
Data	5-5
Erase	5-9
Notes	5-11
Print/upload data	5-7
Select	5-5
Store	5-10
View data	5-7
PROJECT key	3-3, 5-5

Q

QA Sampling	3-24
-------------------	------

R

Radiation	
Converting units	F-1
Dose	A-5
Exposure	A-6
Monitoring	A-8
Profile	A-19
Safety	A-5
Specifications	B-5
Theory	A-2
Types	A-4
Radioactivity	A-3

Reading.....	4-9
Asphalt.....	4-12
Concrete.....	4-12
Soil	4-10
Store	5-10
Thin layer	4-14
Ready screen.....	3-7
Recalibrate.....	6-11
Recall data.....	5-7
RECALL key.....	3-3
Recharge time.....	B-6
Recover erase	5-9
Reference standard block	1-5, 4-2
Regulations.....	1-3, A-15
Canadian shipping	D-4
U.S. shipping	D-2
Replace	
Alkaline batteries.....	C-20
Gaskets	C-24
NiCad battery pack.....	C-21

S

SAFE position	3-5
Safety warnings (European countries).....	G-3
Sample	
Average separation.....	3-24
Number.....	3-24
Scraper plate.....	1-5, 4-6
Select project.....	5-5
Self-test.....	3-7
Separating the control unit	5-2
Serial	
Connection.....	3-13
Data format.....	B-6
Port setup.....	3-13
Service.....	C-30
Centers.....	iii
Set units	3-18
Setup.....	3-9
Gauge.....	3-10
Printer	3-13

Shielding.....	B-5, A-7
SHIFT key	3-3
Shipper's Declaration for Dangerous Goods.....	D-2
Shipping.....	D-1
Canadian requirements.....	D-4
Case.....	1-5, B-8, B-5
U.S. requirements	D-2
Site	
Preparing test	4-6
QA sampling.....	3-24
Standard count	4-2
Sleep mode.....	3-17, B-6
Soil	
Mode setup.....	3-23
Mode specifications	B-2
Site preparation.....	4-6
Taking measurements	4-10
Source	B-5
Americium-241:beryllium (Am-241:Be).....	2-3, C-8
Cesium-137 (Cs-137).....	2-2, C-8
Decay	C-8
Encapsulation.....	A-8
Gamma ray.....	B-5
Neutron	B-5
Rod inspection	A-9
Rod lubrication	C-23
Rod positions	3-5
Shielding.....	B-5, A-7
Special calibration.....	6-11
Density.....	6-11
Theory.....	2-6
Thin layer.....	6-16
Special European considerations	G-1
SPECIAL key	3-3
Specifications.....	B-1
Spreadsheet.....	3-13
Standard count	4-2
Log.....	E-1
STANDARD key.....	3-3, 4-2
START key	3-4
Stat test.....	C-3

Status	
Battery	3-17, C-19
Current.....	3-9
Store	
Data	5-10
Full	5-12
Measurement	4-16
Measurements.....	4-11, 4-13
Target value	3-21
STORE key.....	3-3, 5-10

T

Taking measurements.....	4-9
TARGET key	3-3
Target values	3-19
Temperature.....	B-8
Test	
Drift	C-5
Leak	C-25
Site preparation.....	4-6
Stat.....	C-3
Theory	2-1
Density.....	2-2
Moisture.....	2-3
Offset	2-6
Radiation	A-2
Special calibration	2-6
Thin layer	2-5
Thermalization.....	2-3
Thermoluminescent dosimeter (TLD).....	A-8
THICKNESS key	3-3
Thin layer	2-5
Mode setup	3-23
Mode specifications.....	B-4
Special calibration	6-16
Taking measurements.....	4-14
Time	3-11
Count	3-19
Format	3-12
TIME key	3-3, 3-19

Training	1-3, A-15
Hazmat	D-3
Transport case	1-5, B-8, B-5
Transport Packaging of Radioactive Materials	
Regulations (TPRM)	D-4
Transportation	
Canadian requirements	D-4
U.S. requirements	D-2
Transportation of Dangerous Goods Act and	
Regulations (TDG)	1-3, D-4
Trench offset	2-6, 6-2, 6-9
Troubleshooting	C-9
Tungsten blocks, cleaning	A-11

U

U.S. shipping requirements	D-2
Unit conversion	F-1
Units, measurement	3-18
Unpacking	1-6
Upload	
Drift test	C-7
Project data	5-7
Stat test	C-4
Upload project data	H-3

V

Vertical structure offset	2-6, 6-2, 6-9
View project data	5-7
Void ratio	3-27
Voidless density value	3-19

W

Warmup	3-7
Wet density offset	2-6, 6-2, 6-3

Y

YES key	3-4
---------------	-----

NOTES

NOTES

WARRANTY

TROXLER ELECTRONIC LABORATORIES, INC.

LIMITED WARRANTY

TROXLER ELECTRONIC LABORATORIES, INC., and subsidiary, TROXLER INTERNATIONAL, LTD., hereinafter referred to as "TROXLER," warrants this instrument, Model 3450, Serial Number _____, against defects in material and workmanship for a period of 18 months from date of shipment. For gauges sold through authorized TROXLER representatives, the date of shipment will be as of the transfer from representative to purchaser. During the applicable warranty period, TROXLER's obligation under this warranty shall be limited exclusively to the repair at no charge, except for shipping to and from TROXLER'S plant, of any instrument which may prove defective under normal use and which TROXLER's examination shall disclose to its satisfaction to be thus defective. Normal use is defined for the purpose of this warranty as operation under normal load, usage, and conditions with proper care and maintenance and competent supervision. In no event shall TROXLER be held liable for damages, delays, or losses consequential, incidental, or otherwise attributable to the failure of this instrument or radioactive material contained therein. TROXLER's liability being specifically limited to repair as stated hereinabove. This warranty is automatically initiated except where modified by contractual or other written and signed agreement.

THERE ARE NO WARRANTIES WHICH EXTEND BEYOND THE DESCRIPTION ON THE FACE HEREOF, AND THIS WARRANTY IS EXPRESSLY IN LIEU OF ALL OTHER WARRANTIES, EXPRESSED OR IMPLIED, AND TROXLER NEITHER ASSUMES, NOR AUTHORIZES ANYONE TO ASSUME FOR IT ANY OTHER LIABILITY IN CONNECTION WITH THE SALE OF THE INSTRUMENT. THIS WARRANTY SHALL NOT APPLY TO THE INSTRUMENT OR ANY PART THEREOF, WHICH HAS BEEN SUBJECTED TO DAMAGE BY ACCIDENT, NEGLIGENCE, ALTERATION, ABUSE, MISUSE, OR SERVICE NOT AUTHORIZED IN WRITING BY TROXLER. SUCH DAMAGE TO INCLUDE BUT NOT BE LIMITED TO BURNING OF CIRCUIT BOARDS AND HARNESS FROM IMPROPER SOLDERING TECHNIQUES AND DAMAGE TO THE INSTRUMENT DUE TO PURCHASER'S FAILURE TO PERFORM MAINTENANCE AS OUTLINED IN THE AUTHORIZED OPERATOR'S MANUAL. DUE TO THE NATURE OF THEIR USE, MECHANICAL ACCESSORY PARTS AND BATTERIES ARE WARRANTED FOR 90 DAYS ONLY FROM DATE OF SHIPMENT.

TROXLER ELECTRONIC LABORATORIES, INC.

Troxler International, Ltd.
Troxler Electronics (Canada), Ltd.
3008 Cornwallis Road
Post Office Box 12057
Research Triangle Park, NC 27709 USA

NOTICE TO CONSUMERS

Any disclaimer or limitation on the remedies expressed above shall not be effective to the extent prohibited by state or federal law.

NOTE: THIS WARRANTY EXCLUDES DAMAGE INCURRED IN SHIPMENT. IF THIS INSTRUMENT IS RECEIVED IN DAMAGED CONDITION, THE CARRIER SHOULD BE CONTACTED IMMEDIATELY. ALL CLAIMS FOR DAMAGE IN TRANSIT SHOULD BE FILED WITH THE CARRIER. IF REQUESTED, TROXLER WILL AID IN FILING OF CLAIMS AND/OR LOCATING GAUGES LOST IN TRANSIT.