

Manual of Operation and Instruction

3400-B Series Moisture-Density Gauge

NOTE

Before using the gauge, carefully read this manual. It is especially important to understand the Safety Warnings at the beginning of this manual. Keep this manual in a safe place that is always easily accessible during the use of the gauge.



Troxler Electronic Laboratories, Inc.

Manual of Operation and Instruction 3008 E. Cornwallis Road • P.O.

Box 12057

Research Triangle Park, NC 27709 U.S.A.

Phone: 1.877.TROXLER

Outside the U.S.A.: +1.919.549.8661

Fax: +1.919.549.0761

www.troxlerlabs.com

Troxler products are protected by U.S. and foreign patents.

Copyright © 1988 – 2011

Troxler Electronic Laboratories, Inc.

All Rights Reserved

No part of this manual may be reproduced or transmitted in any form or by any means, electronic or mechanical, including photocopying, recording, or information storage and retrieval systems, for any purpose without the express written permission of Troxler Electronic Laboratories, Inc.

Magnalube-G is a registered trademark of Magnalube, Inc.

PN 103298

Edition 4

September 2011



SAFETY ALERT SYMBOL



The Safety Alert Symbol shall appear within this manual. Wherever it appears in this manual or on safety signs affixed to the machine, this is to make all aware of the potential for personal injury and to be cautious when these images are present.

Always observe all WARNING, CAUTION, and NOTE recommendations listed within this manual before operating the machine.



TROXLER SERVICE CENTERS

Troxler Corporate Headquarters

P.O. Box 12057
Research Triangle Park, NC 27709
Phone: 1.877.TROXLER (1.877.876.9537)
Outside the U.S.A.: +1.919.549.8661
Fax: +1.919.549.0761

Technical Support

Phone: 1.877.TROXLER
(1.877.876.9537)
TroxTechSupport@troxlerlabs.com

Florida Office & Service Center

2376 Forsyth Road
Orlando, FL 32807
Phone: +1.407.681.4221
Fax: +1.407.681.3188
TroxTechSupport@troxlerlabs.com

Western Office & Service Center

11300 Sanders Drive, Suite 7
Rancho Cordova, CA 95742
Phone: +1.916.631.0234
Fax: +1.916.631.0541
TroxTechSupport@troxlerlabs.com

Troxler Europe & Service Center

Troxler Electronics GmbH
Gilchinger Strasse 33 D.82239
Alling nr. Munich, Germany
Phone: ++ 49.8141.71063
Fax: ++49.8141.80731
troxler@t-online.de

To locate an independent, Troxler-authorized service partner near you, call 1.877.TROXLER (1.877.876.9537).

North Carolina Service Center

3008 E. Cornwallis Road
Research Triangle Park, NC 27709
Phone: +1.919.549.8661
Fax: +1.919.549.0761
TroxTechSupport@troxlerlabs.com

Midwestern Office & Service Center

1430 Brook Drive
Downers Grove, IL 60515
Phone: +1.630.261.9304
Fax: +1.630.261.9341
TroxTechSupport@troxlerlabs.com

Southwestern Office & Service Center

2016 East Randol Mill Rd., Suite 406
Arlington, TX 76011
Phone: +1.817.275.0571
Fax: +1.817.275.8562
TroxTechSupport@troxlerlabs.com

Troxler Electronic Technologies (Zhangjiagang)

1F, Bldg G, No. 1 Guotai North Road
ZJG, China, 215600
Phone: 0086.512.56793702
Fax: 0086.512.56793701
kjin@troxlerlabs.cn

ABOUT THIS MANUAL

The 3400-B Series *Manual of Operation and Instruction* provides detailed instructions for the proper use and care of the 3401 and 3411 gauges as well as radiation safety information.

Chapter 1, Introduction

Provides a brief overview of the gauges and their features

Chapter 2, Parts and Accessories

Contains instructions for unpacking and inspection and describes the controls for the 3401-B and 3411-B.

Chapter 3, 3411 Operating Procedures

Describes procedures for taking standard counts and measurements, and setting target values

Chapter 4, 3401 Operating Procedures

Explains how to take standard counts and measurements

Chapter 5, Special Use Procedures

Contains special procedures, including correction factors, trench measurements, thin lift overlays, and roof moisture

Chapter 6, Gauge Base Electronics

Describes the gauge's electrical components and provides procedures for performing static and drift test

Appendix A, Maintenance & Troubleshooting

Provides maintenance procedures and basic troubleshooting

Appendix B, Radiation Theory and Safety

Describes radiation safety, terminology, and theory

Appendix C, Theory of Operation

Describes how the gauge operates

Appendix D, Specifications

Contains the mechanical, electrical, and environmental performance specifications

Appendix E, Standard Count Log

Provides the count log template for your use.

HOW TO USE THIS MANUAL

The 3400-B Series *Manual of Operation and Instruction* contains information on safely using this unit. Also included in this manual are safety warnings, basic parameter setup, system troubleshooting, and general maintenance.

Do not attempt to operate the gauges before reading this manual and the safety warnings posted on the units. Troxler stresses that *the user is solely responsible* for ensuring safe use. The manufacturer, its subsidiary, representatives, and distributors cannot assume responsibility for any mishaps, damage, or personal injury that may occur from failure to observe the safety warnings in this manual and posted on the unit.

CONVENTIONS USED IN THIS MANUAL

Throughout this manual the following symbols and special formatting are used to reveal the purpose of the text.



WARNING

Warnings indicate conditions or procedures that, if not followed correctly, may cause personal injury.

CAUTION

Cautions indicate conditions or procedures that, if not followed correctly, may cause equipment damage.

NOTE

Notes indicate important information that must be read to ensure proper operation.

<KEY> This style indicates a key or character to press on the keypad.

1. Indicates a procedure with multiple steps.
- ◆ Indicates a list of things needed (such as equipment) or important points to know.
- ▶ Indicates that more than one option is available. Carefully select the option that applies.

TABLE OF CONTENTS

CHAPTER 1: INTRODUCTION

Introduction to the 3400 Series 1-2
Licensing and Regulations 1-4

CHAPTER 2: PARTS AND ACCESSORIES

Unpacking and Inspection 2-2

CHAPTER 3: 3411 OPERATING PROCEDURES

Taking Standard Counts 3-2
Taking Soil Measurements 3-4
Taking Asphalt Measurements 3-6
Setting Target Values 3-7

CHAPTER 4: 3401 OPERATING PROCEDURES

Taking Standard Counts 4-2
Taking Soil Measurements 4-4
Taking Asphalt Measurements 4-6

CHAPTER 5: SPECIAL USE PROCEDURES

Corrections for Varying Soils 5-2
Trench Measurements 5-5
Control Strip for Subbase, Base, and Asphalt Paving 5-7
Thin Lift Overlays 5-9
Roof Moisture Measurements 5-12
3400 Series Use on Coal 5-14

CHAPTER 6: GAUGE BASE ELECTRONICS

Electronic and Detector Service 6-2
Stability and Drift Tests 6-3

Gauge Base Electronics..... 6-7

APPENDIX A : MAINTENANCE & TROUBLESHOOTING

Charging BatteriesA-2
Mechanical Maintenance.....A-3
Troubleshooting.....A-7
Calibration..... A-10
Returning the Gauge for Service.....A-12
Replacement Parts..... A-13

APPENDIX B : RADIATION THEORY & SAFETY

Radiation Theory and Safety.....B-2
Working with Radiation Sources.....B-12

APPENDIX C : THEORY OF OPERATION

Density..... C-2
Moisture..... C-5

APPENDIX D : SPECIFICATIONS

Measurement SpecificationsD-2
Mechanical SpecificationsD-4
Radiological SpecificationsD-6
Electrical SpecificationsD-7

APPENDIX E : STANDARD COUNT LOG

WARRANTY

LIST OF FIGURES

Figure 1. Gauge and Accessories	1-3
Figure 2. 3411-B Front Panel Controls	2-4
Figure 3. 3401-B Front Panel Controls	2-6
Figure 4. Roller Pattern	5-8
Figure 5. Thin Lift Overlay Nomograph (SI Units).....	5-10
Figure 6. Thin Lift Overlay Nomograph (US Customary Units)	5-11
Figure 7. Midpoint of Interval	5-12
Figure 8. Midpoint of Interval	5-13
Figure 9. Statistical Stability Test	6-6
Figure 10. 3411-B Display Test Sequence	6-8
Figure 11. 3411-B Rotary Switch Test Format	6-9
Figure 13. Diagram of an Atom	B-2
Figure 14. Variation of Radioactive Emission	B-5
Figure 15. Effects of Distance on Exposure	B-8
Figure 16. Direct Transmission and Backscatter Geometries	C-3
Figure 17. Backscatter Surface Density Effects	C-4
Figure 18. Effect of Moisture on Depth	C-8

LIST OF TABLES

Table 1. Sample Moisture Correction Chart	5-3
Table 2. Key Codes for Keyboard Test Routines	6-10
Table 3. Radiation Profile.....	B-9
Table 4. Neutron Thermalization and Absorption Data	C-6

Chapter 1:

Introduction

This chapter covers the following topics and tasks:

- ✓ An introduction to the 3401 and 3411 gauges
- ✓ Regulatory information

Introduction to the 3400 Series

The 3400 series Surface Moisture-Density gauge is designed to measure the moisture content and density of soils, soil bases, aggregate, concrete, asphalt treated bases, and asphalt pavement. With a custom calibration or offset, the gauge can also be used on other materials. The 3400 series gauges allow you to quickly and precisely determine this moisture content and density without the use of core samples or other destructive methods.

Using direct transmission or backscattered gamma radiation, the 3400 series gauges determine the density of materials by counting the number of photons emitted by a cesium-137 source, which return to the G-M detectors in the gauge base. These detectors detect the radiation and the counts are converted into a density reading.

Utilizing the principle of neutron thermalization, the 3400 series gauges determine the moisture content of soils and soil-like materials. Hydrogen (water) in the material slows neutrons emitted from an americium-241:beryllium source. Detectors located in the base detect the slowed neutrons.

The 3400 series gauges meet or exceed all the requirements of ASTM Standards C1040, D6938, D2950, and AASHTO T-310.

The Model 3411-B stores all calibration constants needed to compute and display wet density, moisture, dry density, percent moisture, and percent compaction in either kilograms per cubic meter or pounds per cubic foot.

The Model 3401-B is a simpler gauge. It displays measured counts and users must perform calculations manually. Measurement results are determined using computer derived calibration tables. The Model 3401-B can easily be converted to a Model 3411-B by changing the keypad and display, also known as the scaler.



Figure 1. Gauge and Accessories

Licensing and Regulations

Owners of this gauge must maintain a current radioactive materials license as long as they own the gauge, even if it is in storage and not actively being used.

Owners are encouraged to require study of this manual by operator(s) before allowing any use of the instrument. While no radiation hazard exists for operator(s) during normal use, *a potential hazard does exist if improperly used.*

The sections of the manual covering radiological safety should be required reading for all operators and potential operators. If these sections are not completely understood, seek assistance from Troxler, an appointed Troxler representative, or others designated within the user organization. Additional nuclear safety information is available by completing our Nuclear Gauge Training course.

As changes are made to local, state and federal regulations on a continuing basis, the owner/user must maintain current status with these regulations. *The responsibility for compliance ultimately falls upon the owner.* The owner may also wish to purchase and subscribe to Titles 10 and 49 of the *Code of Federal Regulations* in addition to applicable local and state regulations. These are available at <http://hazmat.dot.gov>.

Chapter 2:

Parts and Accessories

This chapter covers the following topics and tasks:

- ✓ Performing an inventory and inspection
- ✓ Description of 3401-B and 3411-B controls

Unpacking and Inspection

Upon receipt of the gauge from the factory, a complete inspection and inventory should be performed. If the shipping case, any other part of the container, and/or the gauge appears to be damaged, notify the carrier and your Troxler representative *immediately*.

For shipping to another location or back to the factory, save the box and any packing material.

Check to see if the following have been included:

- ◆ **Gauge:** instrument containing all electronic modules, battery packs, detectors, and radioactive sources.
- ◆ **Reference Block** (also called the "standard"): provides a uniform reference material for gauge adjustment to compensate for source decay and stability tests.
- ◆ **Drill Rod:** used to prepare a hole for a direct transmission reading. Do not use the source rod for this purpose!
- ◆ **Drill Rod Removal Tool** (also called the "extractor"): used to remove the drill rod from the test material.
- ◆ **Scraper Plate:** used to prepare the test site and aid in guiding the drill rod into the soil.
- ◆ **AC Battery Charger:** operates from 115 or 230 volt power at 50-60 Hz.
- ◆ **DC Battery Charger:** operates when plugged into a DC charger of a 12-volt negative ground vehicle system.

The front panel module is the only difference between the 3401-B and the 3411-B gauges. The 3401-B scaler does not have electronics that store data and perform calculations.

The following is a functional description of the 3411-B controls. These items are labeled in Figure 2 on page 2-4.

1. Connector cover for battery charger cables.
2. The liquid crystal display (LCD) shows accumulated counts and computed results, and it also has status indicators as shown below:

ERR – Accumulation in progress or a computational error has occurred.

BAT – Low battery warning; batteries are in need of a recharge. The gauge will function normally for several hours before it automatically shuts off.

– – Displayed number is negative in value.

3. PWR/TIME switch turns the unit on and selects the time period for an accumulation. The SLOW, NORM, and FAST positions correspond to accumulation periods of 4, 1, or 0.25 minutes, respectively.
4. The keypad is color coded for ease of use. Five keys are “dual function.” The yellow <SHIFT> key activates functions labeled in yellow. The functions labeled in white are operational when <SHIFT> is not depressed.

The <STANDARD/MEASURE> key is used to start an accumulation of either a standard or a measure count.

The second row of keys is used to determine which register will be displayed. The <MS> (Moisture Standard) and <DS> (Density Standard) keys are used to display the standard counts.

The <MC> (Moisture Count) and <DC> (Density Count) keys are used to display the measure counts.

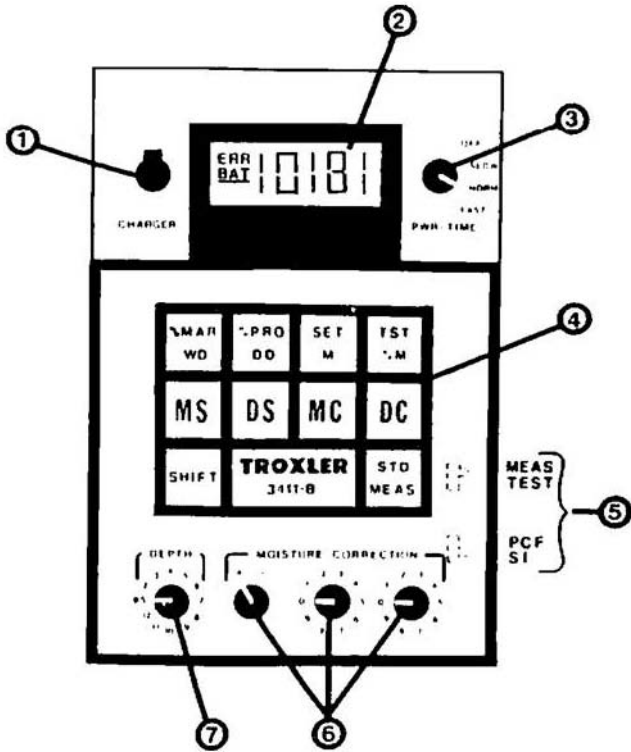

Figure 2. 3411-B Front Panel Controls

The top row of keys is for computations and test functions. The white keys on the top row (WD, DD, M %M) compute wet density, dry density, moisture content, and percent moisture, respectively. The %MAR and %PRO keys are used to compute percent of Marshall and percent of Proctor. The SET key is used to read or change the value of the established Proctor or Marshall target.

The **(TST)** key is used to initiate the self-test routines; these test routines are described starting on page 6-8.

5. The group of slide switches is located on the printed circuit board behind the front panel. To gain access to these switches, loosen the four thumbscrews in each corner of the front panel and lift it out of the gauge cavity. The functions of the switches are listed below:

MEAS/TST switch – In the TST position, a known signal is applied to the counter inputs for testing purposes. In the MEAS position, the gauge functions normally.

PCF/SI switch – This toggles the display units for computed results. In the PCF position, computations results are displayed in pounds-per-cubic foot. In the SI position, results are displayed in kilograms-per-cubic meter.

6. Moisture correction switches are used to offset the gauges' moisture readings.
7. The Depth switch is always set to the same value as the depth of the source rod when performing a measurements.

The 3401 scaler is shown in Figure 3.

The PWR/TIME switch is used to select SLOW, NORMAL, and FAST count times (4 minutes, 1 minute, and 15 seconds). The display switch chooses MOISTURE or DENSITY, and the **(START)** key begins count accumulation.

Moving the MEAS/TST switch to TST toggles the test routine (see Chapter 6).

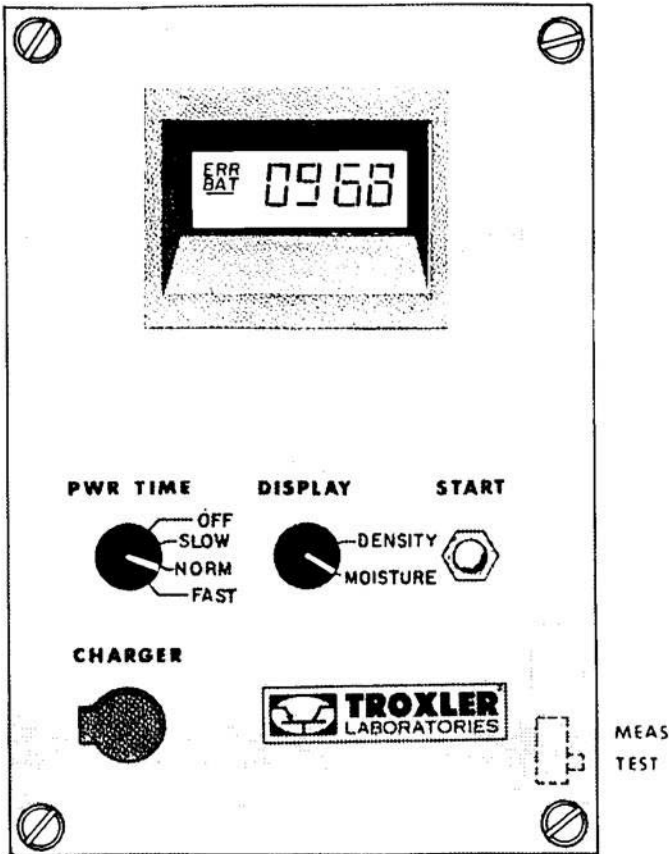

Figure 3. 3401-B Front Panel Controls

Chapter 3: 3411

Operating Procedures

This chapter covers the following topics and tasks:

- ✓ Performing standard counts
- ✓ Instructions for taking measurements
- ✓ Setting target values

NOTE

For added safety, the source rods on the 3400 series gauges automatically retract to the SAFE position when picked up by the handle.

Taking Standard Counts

1. Turn the gauge on. It will perform stabilization procedures. Please allow it to warm up for ten minutes.
2. Place the reference block on a solid surface with a density of 1600 kg/m³ (100 pcf) or greater, such as compacted soil, asphalt, or concrete. The gauge should be at least 3 meters (10 ft.) from any large object such as a vehicle or wall. There should be no other radiological sources within ten meters (30 ft.).
3. Place the gauge on the reference block with the keypad end against the metal plate between the raised edges. Be sure the gauge is properly seated on the recessed surface of the reference block.
4. Remove the padlock from the source rod. Leave the source rod in the SAFE position.
5. Turn the PWR/TIME switch to the SLOW (4 minute) position. Press the <SHIFT> and <STANDARD> keys at the same time. In the display window you will see the gauge counting and ERR in the upper-left corner.
6. After four minutes the counting will stop. Both moisture and density standard counts are stored in the gauge. Press the <DS> key and record the density standard count. Press <MS> and record the moisture standard count.
7. Return the reference block to the case.
8. Record the standard counts in the log book.

NOTE

To verify gauge stability, use the daily log of moisture and density standard counts.

Assuming the gauge is new or just calibrated, the acceptable standard count limits are:

For the first four days

$\pm 1\%$ each day for DS (density standard) as compared to the reference standard count (factory calibrated) value and

$\pm 2\%$ each day for the MS (moisture standard) as compared to the reference standard count

After four days

$\pm 1\%$ for DS and

$\pm 2\%$ for MS as compared to the average of the last four daily DS and MS values.

This averaging procedure is maintained until the instrument is returned to the factory for recalibration. Recalibration requires the log procedure to be started over. Standard count log sheets may be found on the last pages of this manual. In the event that standard counts do not fall into the above percentages, an instability is suspected. Refer to page 6-3 for more information about stability (stat) tests.

Taking Soil Measurements

1. If the surface is not relatively smooth, use the scraper plate provided with the gauge. Sand or native fines may be used to fill voids.
2. Using the drill rod and drill rod guide, drive a hole at least 2 inches (50 mm) deeper than the desired test depth. If the drill rod extraction tool is available, place the drill rod through the extraction tool into the scraper plate guide. Remove the drill rod by rotating and pulling straight up.

Do not loosen the drill rod by tapping from side-to-side with a hammer. The drill rod will turn easier if it is turned after every few inches of raising it from the hole.

3. Place the source rod in the hole to the desired depth of measurement by seating the handle in the proper notch.
4. Pull the gauge so the source rod is in firm contact with the side of the hole toward the front of the gauge.
5. Turn the depth indicator to the desired depth. Each number represents 1 inch or 25 mm.
6. Turn the PWR/TIOME switch to the NORMAL (1 minute) position.
7. Turn the moisture correction switches to "00" or to the previously determined correction factor.

NOTE

On soils that have not previously been checked by a nuclear gauge, a moisture sample may be obtained at a point of test to determine if a correction factor is needed. If a correction factor is necessary, it can be determined by following the procedures starting on page 5-2. A correction factor for a given soil need only be determined once. The correction can then be reused in future testing with the same gauge.

1. Press the **<MEASURE>** key. The display will show the gauge counting and ERR in the upper-left corner. After one minute the counting will stop.
2. Press **<WD>** and record the Wet Density (kg per cubic meter or PCF).
3. Press **<M>** and record the Moisture.
4. Press **<DD>** and record the Dry Density (WD-M).
5. Press **<%M>** and record percent moisture (M divided by DD)

Taking Asphalt Measurements

1. Place the gauge on the surface of the asphalt, choosing a smooth surface for best results. Sand can be used to fill large voids. Care must be taken to ensure that the gauge is resting on the asphalt and not on the sand. This procedure is only helpful when the voids are large.
2. Place each hand on opposite corners of the base to check for rocking.
3. Turn the depth indicator switch to BS.
4. Turn the PWR/TIME switch to the FAST (15 second) position or the NORMAL position.
5. Place the source rod in the backscatter position, making sure the source rod is in the BS notch and not resting on the asphalt.
6. Press **<MEASURE>**. The window will show the gauge counting and ERR in the upper-left corner.
7. After the counting stops, press **<WD>** and read the Wet Density.

Setting Target Values

The 3411-B can display the percent compaction achieved at the test location if a target value for the particular material is entered into the gauge register. Follow the procedure below to enter a Dry Density (Proctor) target or a Wet Density (Marshall) target, which is determined in the laboratory.

1. Press **<SHIFT>** and **<SET>** and read the stored value. For asphalt, the Marshall value should be stored in this register. For soils, the Proctor value should be stored.
2. If the value is too low, place the (+/-) switch on (+). Press **<SHIFT>** and **<SET>** and THEN release the **<SHIFT>** key. The display value should increase; release the **<SET>** key when the desired value is displayed. If the value is too high, utilize the same procedure but with the switch on (-).
3. On soils and bases, press **<SHIFT>** and **<%PRO>** to read the percent Proctor.
4. On asphalt, press **<SHIFT>** and **<%MAR>** to read the percent Marshall.

NOTES

Chapter 4: 3401

Operating Procedures

This chapter covers the following topics and tasks:

- ✓ Performing standard counts
- ✓ Instructions for taking measurements

NOTE

For added safety, the source rods on the 3400 series gauges automatically retract to the SAFE position when picked up by the handle.

Taking Standard Counts

1. Turn the gauge on. It will perform stabilization procedures. Please allow it to warm up for ten minutes.
2. Place the reference block on a solid surface with a density of 1600 kg/m^3 (100 pcf) or greater, such as compacted soil, asphalt, or concrete. The gauge should be at least 3 meters (10 ft.) from any large object such as a vehicle or wall. There should be no other radiological sources within ten meters (30 ft.).
3. Place the gauge on the reference block with the keypad end against the metal plate between the raised edges. Be sure the gauge is properly seated on the recessed surface of the reference block.
4. Remove the padlock from the source rod. Leave the source rod in the SAFE position.
5. Turn the PWR/TIME switch to the SLOW (4 minute) position. Press the **<SHIFT>** and **<STANDARD>** keys at the same time. In the display window you will see the gauge counting and ERR in the upper-left corner.
6. After four minutes the counting will stop. Both moisture and density standard counts are stored in the gauge. Press the **<DS>** key and record the density standard count. Press **<MS>** and record the moisture standard count.
7. Return the reference block to the case.
8. Record the standard counts in the logbook.

NOTE

To verify gauge stability, use the daily log of moisture and density standard counts.

Assuming the gauge is new or just calibrated, the acceptable standard count limits are:

For the first four days

± 1% each day for DS (density standard) as compared to the reference standard count (factory calibrated) value and

±2% each day for the MS (moisture standard) as compared to the reference standard count

After four days

±1% for DS and

±2% for MS as compared to the average of the last four daily DS and MS values.

This averaging procedure is maintained until the instrument is returned to the factory for recalibration. Recalibration requires the log procedure to be started over. Standard count log sheets may be found on the last pages of this manual. In the event that standard counts do not fall into the above percentages, an instability is suspected. Refer to page 6-3 for more information about stability (stat) tests.

Taking Soil Measurements

1. If the surface is not relatively smooth, use the scraper plate provided with the gauge. Sand or native fines may be used to fill voids.
2. Using the drill rod and drill rod guide, drive a hole at least 2 inches (50 mm) deeper than the desired test depth. If the drill rod extraction tool is available, place the drill rod through the extraction tool into the scraper plate guide. Remove the drill rod by rotating and pulling straight up.

Do not loosen the drill rod by tapping from side-to-side with a hammer. The drill rod will turn easier if it is turned after every few inches of raising it from the hole.

3. Place the source rod in the hole to the desired depth of measurement by seating the handle in the proper notch.
4. Pull the gauge so the source rod is in firm contact with the side of the hole toward the front of the gauge.
5. Turn the depth indicator to the desired depth. Each number represents 1 inch or 25 mm.
6. Turn the PWR/TIME switch to the NORMAL (1 minute) position.
7. Press the **(START)** button. In the window display you will see the gauge counting and ERR in the upper-left corner. After one minute the counting will stop.
8. Turn the display switch to density to record the density count. Turn the switch to moisture to record the moisture count.

9. Obtain the density *count ratio* by dividing the moisture count by the moisture standard count. The fractional result is then correlated with the closest moisture value found in the calibration tables supplied with the gauge. Interpolation may be necessary.
10. Calculate the Dry Density (DD) as follows: $DD = WD - M$.
11. Calculate the Percent Moisture (%M) as follows:

$$\%M = \frac{M}{DD} \times 100$$

NOTE

On soils that have not previously been checked by a nuclear gauge, a moisture sample may be obtained at a point of test to determine if a correction factor is needed. If a correction factor is necessary, it can be determined by following the procedures starting on page 5-2. A correction factor for a given soil need only be determined once. The correction can then be reused in future testing with the same gauge.

Taking Asphalt Measurements

1. Place the gauge on the surface of the asphalt, choosing a smooth surface for best results. Sand can be used to fill large voids. Care must be taken to ensure that the gauge is resting on the asphalt and not on the sand. This procedure is only helpful when the voids are large.
2. Place each hand on opposite corners of the base to check for rocking.
3. Turn the depth indicator switch to BS.
4. Turn the PWR/TIME switch to the FAST (15 second) position or the NORMAL (1 minute) position (recommended).
5. Place the source rod in the backscatter position, making sure the source rod is in the BS notch and not resting on the asphalt.
6. Press **(START)**. The window will show the gauge counting and ERR in the upper-left corner.
7. When the counting stops, turn the display switch to density and read the density count.
8. Obtain the *count ratio* by dividing the density count by the density standard count.
9. Use the *count ratio* to look up the density in the calibration tables supplied with the gauge.

Chapter 5:

Special Use Procedures

This section covers the following topics and tasks:

- ✓ Correction factors
- ✓ Trench measurements
- ✓ Thin lift overlays
- ✓ Roof moisture measurements

Corrections for Varying Soils

Density Correction

The 3400 series is calibrated for soils, aggregates, concrete, and asphalt with a density range of 1100 to 2700 kg/m³ (70 to 170 pcf). Corrections to the density calibrations are only necessary in rare conditions such as work involving industrial waste, mine tailings, and coal. For a general discussion of calibration, see page A-10. If working with coal, see page 5-14. For other applications, contact your Troxler representative.

Moisture Correction

The 3400 series measures moisture by determining the hydrogen (H) content of the soil and relating this to water (H₂O) content. In some soils there are compounds other than water that contain hydrogen. There are also elements in some soils that absorb neutrons, thereby lowering the count rate.

The 3400 series gauges are calibrated for soils without neutron-absorbing elements or components other than water containing hydrogen and need not be adjust for most soils.

To determine a correction factor, use the following procedure:

1. Take five or more oven dry and gauge sample pairs. Be sure oven dry samples are at least 1000-2000 grams taken under the center of the gauge to a depth of 15-20 cm (6-8 in.). Be sure nuclear tests are taken with the Moisture Correction set at 00 on the 3411-B keypad.
2. Prepare a chart as shown below.

Sample No.	%M Oven Dry	%M Gauge	%Oven Dry - % Gauge
1	4.5	8.6	-4.1
2	4.0	5.8	-1.8
3	7.2	9.7	-2.5
4	6.7	8.6	-1.9
5	5.1	7.3	-2.2
Average	5.5	8.0	-2.5

Table 1. Sample Moisture Correction Chart

The difference between the oven dry and the gauge samples is expected to vary from sample to sample due to normal variation. If the difference indicates the gauge is sometimes higher and sometimes lower than the oven dry, no correction may be needed. If the difference indicates the gauge reads *consistently* higher or lower than the oven dry, a correction factor is needed.

To determine the correction factor, calculate the average value and proceed as follows:

FOR THE 3411-B

Calculate the correction factor using the average value.

$$\frac{\%M \text{ Oven Dry} - \%M \text{ Gauge}}{100 + \%M \text{ Gauge}} \times 1000$$

Dial this value into the moisture correction switches on the 3411-B scaler, paying attention to the algebraic sign. In the example above, the moisture correction is:

$$\frac{-2.5}{100 + 8.0} \times 1000 = -23$$

The correction is independent of dry density and wet density and adjusts the apparent moisture to true moisture regardless of dry density. This value can be used for all future tests on the same soil type.

NOTE

Occasionally, non-homogenous soils may be encountered in which differences between oven dry and gauge readings are not consistent. In this case, one correction factor is not practical.

FOR THE 3401-B

Calculate the moisture from the oven dry in kg/m³ or pcf:

$$M \text{ Oven Dry} = \frac{\%M \text{ Oven Dry} \times WD}{\%M \text{ Oven Dry} + 100}$$

Here, WD = Wet Density

Next, calculate the correction factor in kg/m³ or pcf:

$$\text{Correction factor} = M \text{ Oven Dry} - M \text{ Gauge}$$

This factor should be used to adjust the gauge moisture reading, paying attention to the algebraic signs.

This correction factor is accurate at the wet density and percent moisture taken. Therefore, the samples taken should be close to optimum compaction. This value can be used on all future tests on the same soil type.

$$M \text{ Oven Dry} = \frac{5.5 \times 130}{5.5 + 100} = 6.8$$

$$\text{Correction Factor} = 6.8 - 9.6 = -2.8 \text{ PCF}$$

Trench Measurements

Direct transmission wet density will not be affected by a trench wall or vertical structure. Moisture and dry density (WD-M) may be affected when a gauge is operated within 0.6 meters (24 inches) of a large vertical structure with a moisture content of 240 kg/m^3 (15 pcf) or greater.

For trenches with a width of one meter (40 inches) or more, the moisture error will be less than 24 kg/m^3 (1.5 pcf) when the measurement is performed in the center of the trench.

Correction Procedure

1. Obtain the daily standard counts following the steps outline on page 3-2. (If a valid set of standard counts has already been obtained, it may be used.) Note that the standard counts are taken at a site *away* from the trench.
2. Enter the trench and take a set of counts (not a standard count) with the gauge *placed on the reference standard* at the desired test site. The distance from the wall must be the same as the area to be tested. This count may be taken with the PWR/TIME switch set on NORM. On the 3411, do not press **<SHIFT>** because your standard count will be erased.
3. Determine the moisture offset value by subtracting the moisture standard count from the second moisture count obtained in the trench. Record this number for future tests performed at this site and with this gauge at the same distance from the wall.

ON THE 3401

Subtract the offset value from the moisture measurement count before you divide by the moisture standard count.

ON THE 3411

Set this value on the MOISTURE CORRECTION switches. Press and hold the **<SHIFT>** key while depressing **<MC>**. The value set on the MOISTURE CORRECTION switches should now appear on the display. This value is preset negative so the + switch need not be moved.

The entered value for moisture offset will be retained by the gauge until a) it is changed by entry of a new offset, b) a new set of standard counts is taken, or c) the gauge is turned off.

Be sure to return the moisture correction switches to 00 or to the values representing the proper moisture correction factor after entering the trench correction value.

The moisture offset value can be removed by setting the MOISTURE CORRECTION switches to 00 and pressing **<SHIFT>** and **<MC>**.

Control Strip for Subbase, Base, and Asphalt Paving

The Virginia Highway Research Council developed an alternate method to take advantage of the fast testing capability of the instrument. The procedure involves the use of a *control strip*. While originally developed for paving, it is often used on plant-mixed base material.

The typical procedure involves the selection of a test site 100 meters (300 feet) long and the width of the paver. Compaction is accomplished with rollers and a nuclear density gauge is used to measure density between passes of the roller. From this information a roller pattern is established as shown in Figure 4.

Compaction is continued until there is no further increase in density. At this point, the maximum density is determined by taking the average of 10 randomly selected sites on the control section.

Using this method, the specifications for the project are normally established as 98% of the control section density. Tests are usually run on 2800 square meter (2800 square yard) sections and the average of five tests used to establish passing conditions for each section. Each test must be 95% or over and the average must be 98% or over.

A new control section must be established when the material source has changed or after 10 test sections have been approved.

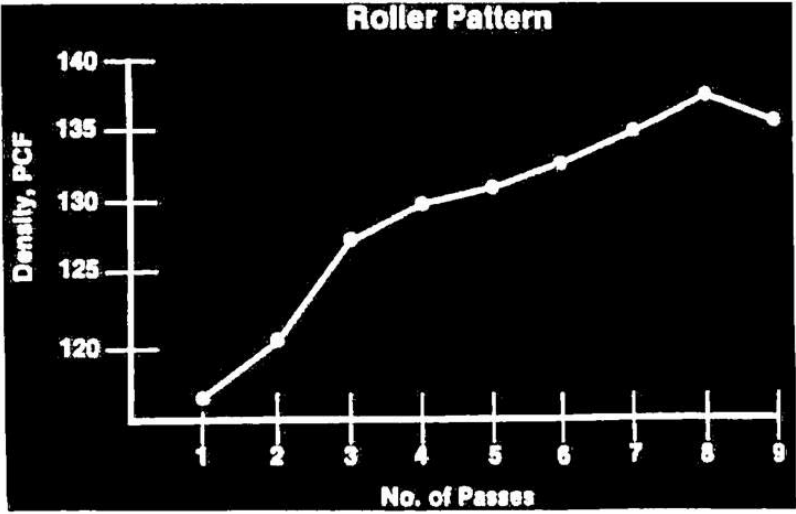

Figure 4. Roller Pattern

Thin Lift Overlays

Nuclear gauges, when used in the backscatter mode on overlays less than 7 cm (3 in.), have certain limitations that must be overcome in order to obtain correct densities. The problem arises because the gauge “sees” through the thin overlay and therefore the underlying material influences the reading.

Recognizing this problem, a nomograph was developed that allows rapid determination of overlay density. To use the nomograph, you must know the density of the bottom layer and the thickness of the top layer.

The simplest method of determining the bottom layer density is by taking nuclear density tests before the overlay is applied. Pavement is then placed and compacted.

Backscatter density measurements are made on top of the new pavement. Knowing the mat thickness, the density of the top layer may be determined from the nomograph.

NOTE

These procedures and nomographs are applicable only to the 3401-B and 3411-B gauges. They are not valid for other Troxler gauges or gauges from other manufacturers.

Following are examples with nomographs for SI and US Customary Units.

Overlay Example – SI Units

In this example, the bottom layer density (left scale) is 2080 kg/m³ with a mat 30 mm thick overlaying it. A backscatter density test on the top of the mat (right scale) yielded a result of 2220 kg/m³ (right) and extended to the right.

The correct density for the top layer is then read from the nomograph as 2321 kg/m³ on the right scale.

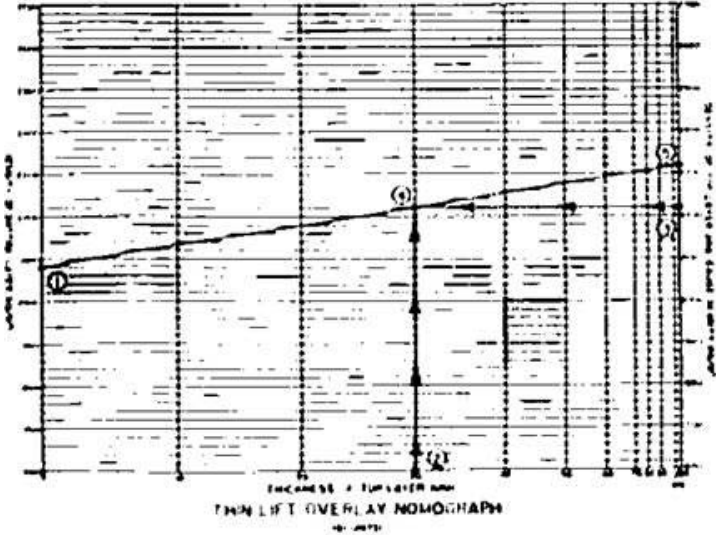

Figure 5. Thin Lift Overlay Nomograph (SI Units)

Overlay Example – US Customary Units

In this example, the bottom layer density (left scale) is 130 pcf with a mat 1.2 inches thick overlaying it. A backscatter density test on the top of the mat (right scale) yielded a result of 138.5 pcf. A line is then drawn from 130 pcf on the left scale through the intersection of 1.2 inches (bottom) and 138.5 pcf (right) and extended to the right.

The correct density for the top layer is then read from the nomograph as 144.5 on the right scale.

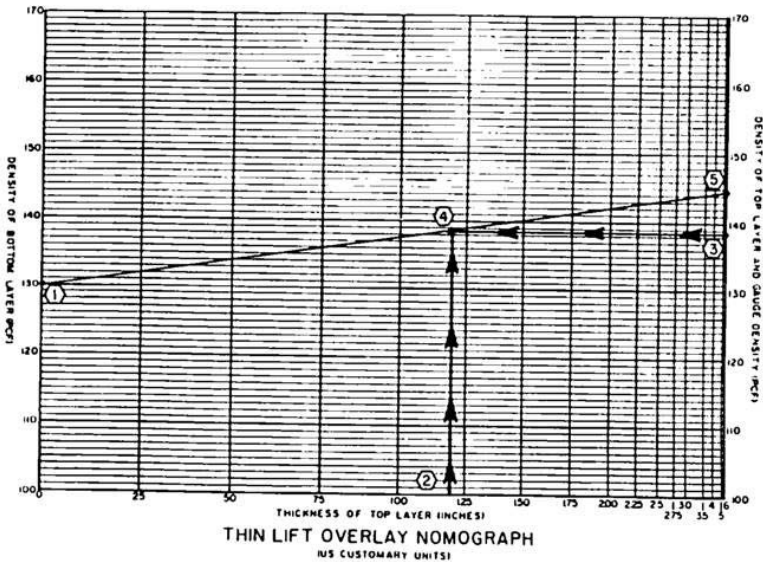

Figure 6. Thin Lift Overlay Nomograph (US Customary Units)

Roof Moisture Measurements

The 3400 can be used easily and effectively for determining the presence of elevated moisture levels in built-up roofing systems. Troxler also manufactures the Model 3216, which is specifically designed for roof moisture measurement.

To test roofs for moisture, a grid is first established on the roof to be surveyed. The grid can be made using a lightweight chain, rope, etc. A spray paint dot is all that is needed to mark the intersections. A roof plan of the structure at this point is also handy, showing vents, walkways, drains, heat and/or air conditioning units, etc.

Place the 3401 or 3411 in the safe carrying position with the PWR/TIME switch moved to FAST (15 seconds). Perform a measurement and record the moisture count (MC) values for each grid point on the roof. Then construct a frequency histogram that plots count rates versus frequency of occurrence. An example is shown below.

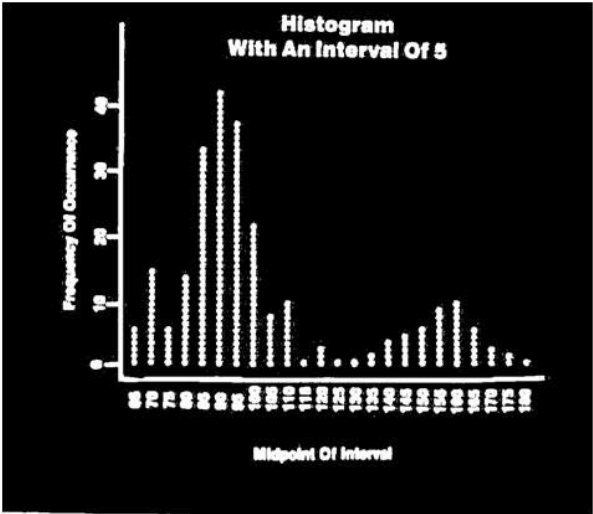

Figure 7. Midpoint of Interval

Data reduction is computed using the standard deviations which group the data into “dry” and “wet” categories. The limits of the “dry” area are shown below.

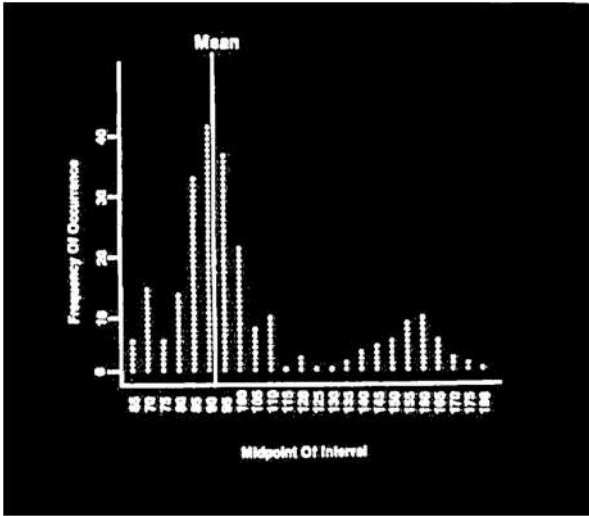

Figure 8. Midpoint of Interval

After limits of the “dry” areas are statistically established, count rates beyond the three standard deviation boundary could be considered to indicate the presence of moisture or other hydrogen-bearing materials. This area can then be “cut” into three or four levels for further interpretation.

You may wish to consider taking core samples based on histogram analysis as a means of determining absolute moisture content.

3400 Series Use on Coal

The wet density of coal often lies below the calibrated range of 1100-2700 kg/m³ (70-170 pcf) of the gauge. Many users adjust the calibration using samples prepared to simulate field conditions.

A minimum of three to four “standards” should be constructed, each having dimensions of 50 cm x 50 cm (20 in. x 20 in.). To represent infinite volume to the instrument, each box should be 10 cm or 4 in. deeper than the maximum depth setting to be used. Each box is then weighed and compacted to a calculated wet density value and count rates are accumulated for each.

Repeat this procedure and vary the compaction effort for each “standard” to achieve different wet densities.

A correlation can then be established between wet density of material at the site and values obtained on the standards. Backscatter mode is not recommended for use on coal.

Moisture data obtained with the instrument is subject to error due to the chemical composition of the material, which is inherently high in hydrogen content. Therefore, most operators use conventional methods for moisture readings on coal.

Chapter 6: Gauge Base Electronics

This section covers the following topics and tasks:

- ✓ Electrical components
- ✓ Stat, drift, and other tests

Electronic and Detector Service

The 3400-B series utilizes a high degree of integrated circuit technology. For this reason the reliability level is very high and repair is relatively simple because it consists of module or PC Board replacement.

If the gauge will not perform the functions described in the operating procedures, refer to the Troubleshooting section (starting on page A-7) or contact a Troxler representative.

If all the gauge functions perform normally but readings are suspect, perform stability and drift tests as outlined in the next section. If the gauge operates normally and is stable but field density and moisture readings are suspect, refer to the Troubleshooting section.

Stability and Drift Tests

If a gauge performs all functions in the operating sections normally, the final indication that the gauge is electronically correct is passing the stability and drift tests. Passing these tests means a gauge is suitable for field use, if properly calibrated. The Quick Field Stability Check also provides a quick check of the gauge's performance.

Quick Field Stability Test

If gauge readings are suspect, perform a quick stability test.

1. Turn the gauge on and allow it to warm up for fifteen to twenty minutes. (Ten minutes is adequate for normal field use.)
2. Place the gauge on the reference block in the standard count or SAFE position.
3. Recording each set of counts (DS and MS), take five four-minute standard counts in succession.
4. Calculate the difference between the highest density standard count and the lowest density standard count. The density counts are stable if the percent difference between the highest and lowest density standard count is less than 1%.
5. Calculate the percent difference between the highest moisture standard count and the lowest moisture standard count. The moisture counts are stable if the percent difference between the highest and lowest moisture standard count is less than 2%.

If the standard counts fail one or both of the above tests, return the gauge to the lab to perform statistical stability (stat) and drift tests.

Statistical Stability (Stat) Test

If gauge readings are suspect, perform a stat test as follows. (See the example on the next page.)

1. Turn the gauge on and allow it to warm up for fifteen to twenty minutes.
2. Place the gauge on the reference block in the standard count or SAFE position.
3. Recording all counts, take twenty one-minute readings.
4. Compute the standard deviation (s) and the average (\bar{x}) of the moisture and density readings using the following formulas:

$$\bar{x} = \frac{\sum x}{n} \qquad s = \left[\frac{1}{n-1} \sum_1^n (x - \bar{x})^2 \right]^{\frac{1}{2}}$$

5. Divide the standard deviation of the moisture readings by the square root of the average moisture reading. If this ratio is not within the range of 0.17 to 0.33, check or replace the moisture model and/or high voltage module. If the gauge is still unstable, replace the He³ tube. If the gauge is unstable after replacing the moisture module, high voltage module, and ³He tube, contact your Troxler service department.
6. Divide the standard deviation of the density readings by the average density reading. If this ratio is not within the range of 0.17 to 0.33, check or replace the density module and/or high voltage module. If the gauge is still unstable, replace the G-M tubes. If the gauge is unstable after replacing the density module, high voltage module, and G-M tube, contact your Troxler service department.

Drift Test

If the stat test has passed but gauge readings seem to drift between tests, a *drift test* can check the gauge's long-term drift.

NOTE

The gauge should not be turned off between the stat and drift test. That stat test must be current.

1. After performing the stat test, allow the gauge to sit for three to four hours.
2. Place the gauge on the reference block in the standard count position. Recording all counts, take five SLOW counts.
3. Average these five readings.
4. If the difference between this average and the average taken in the stability test is greater than 1% for moisture, check and replace the moisture module. If the gauge is still drifting, check and replace the He³ tube.
5. If the difference between this average and the average taken in the stat test is greater than 0.5% for density, check and replace the density module. If the gauge is still drifting, check and replace the G-M tubes.

The following is an example of the stat test and drift test.

Test Number n	Moisture Counts (x ₁)	ERROR E=(x ₁ -x̄ ₁)	E ²	Density Counts (x ₂)	ERROR E=(x ₂ -x̄ ₂)	E ²
1	526	3.3	10.89	2400	6.9	47.61
2	521	-1.7	2.89	2379	-14.1	198.81
3	509	-13.7	187.69	2379	-14.1	198.81
4	523	.3	.09	2410	16.9	285.61
5	516	-6.7	44.89	2412	18.9	357.21
6	527	4.3	18.49	2388	-5.1	26.01
7	521	-1.7	2.89	2376	-17.1	292.41
8	522	-.7	.49	2387	-6.1	37.21
9	527	4.3	18.49	2410	16.9	285.61
10	525	2.3	5.29	2394	.9	.81
11	522	-.7	.49	2402	8.9	79.21
12	526	3.3	10.89	2390	-3.1	9.61
13	527	4.3	18.49	2391	-2.1	4.41
14	533	10.3	106.09	2393	-.1	.01
15	524	1.3	1.69	2371	-22.1	488.41
16	525	2.3	5.29	2401	7.9	62.41
17	515	-7.7	59.29	2402	8.9	79.21
18	516	-6.7	44.87	2375	-18.1	327.61
19	533	10.3	106.09	2395	1.9	3.61
20	516	-6.7	44.89	2407	13.9	193.21
	<u>x₁ = 522.7</u>		<u>Σ = 690.18</u>	<u>x₂ = 2393.1</u>		<u>Σ = 2977.80</u>

$$\sqrt{\bar{x}_1} = 22.86 \quad s_1 = \sqrt{\frac{\Sigma}{n-1}} = 6.03 \quad \sqrt{\bar{x}_2} = 48.92 \quad s_2 = \sqrt{\frac{\Sigma}{n-1}} = 12.52$$

$$\text{Ratio} = \frac{6.03}{22.86} = 0.26$$

$$\text{Ratio} = \frac{12.52}{48.92} = 0.26$$

INSTRUMENT DRIFT TEST

Test Number	Moisture Counts	Density Counts
1	520	2392
2	522	2390
3	522	2397
4	520	2384
5	518	2393
Avg =	<u>520.4</u>	<u>2391.2</u>

$$\text{Difference} = 522.7 - 520.4 = 2.3 \quad = 2393.1 - 2391.2 = 1.9$$

$$\text{Drift} = \frac{2.3}{521.6} \times 100 = .44\%$$

$$= \frac{1.9}{2392.2} \times 100 = .08\%$$

Figure 9. Statistical Stability Test

Gauge Base Electronics

The gauge base electronics assembly consists of four sealed modules, which are field replaceable. It is not anticipated that field repairs will be made to the modules.

This unit contains HIGH VOLTAGE, which can cause shock. In addition to turning off the unit before working on it, discharge the high voltage by shorting across the HV DISACHARGE and GND test points. A wide blade, insulated handle screwdriver is useful for this purpose. These test points are located on the preamplifier board.

Power is supplied to the system by two battery packs that total 10 volts at 40 watt-hours, which are both separately replaceable.

The Battery Monitor contains voltage sensing circuits to activate the BAT alarm symbol when the battery voltage drops below 9.5 ± 0.1 volts. Another voltage sensing circuit detects when the battery voltage drops below 8.4 ± 0.1 volts and cuts off the gauge electronics.

NOTE

Either the 3401-B or 3411-B may be operated with a “non-B” base by use of an adapter cable (part number 102855).

3411-B Scaler Module Test Functions

The 3411-B microprocessor controls the majority of the instrument’s functions. If the display indicates four zeros (0000) when the instrument is turned on, the microprocessor is probably working normally.

If the microprocessor is working, there are three self-test routines that can be used to verify proper operation. To enter the routines, depress the <SHIFT> key and the <TST> keys at the same time. Each repeated depression of the <SHIFT> and <TST> keys indexes to the next test.

To return the instrument to the normal mode, hold the <SHIFT> key down while pressing and releasing the <STANDARD> key. Release the <SHIFT> key and the instrument will also return to the normal mode of operation if it is turned off and on again.

SELF-TEST 1: 3411-B DISPLAY TEST

This routine produces a cyclic number sequence that ripples across the display. The exact sequence is shown in the figure below. By watching each digit “count up,” you can verify that the LCD and its associated electronics are working properly.

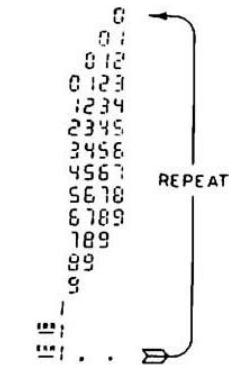

Figure 10. 3411-B Display Test Sequence

SELF-TEST 2: 3411-B ROTARY SWITCH TEST

Assuming that the display test is correct, this routine can be used to verify that the microprocessor is reading the rotary switches correctly. The microprocessor reads the rotary switches and indicates the switch position via the display. The display format is shown in the figure below. Simply rotating a switch and watching the corresponding location on the display is all that is necessary to verify correction operation. A blank indicates a defective switch position.

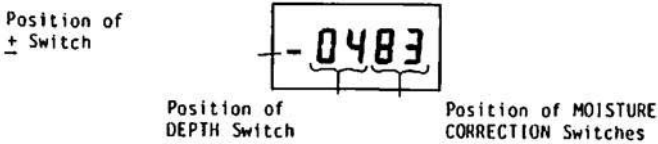

Figure 11. 3411-B Rotary Switch Test Format

SELF-TEST 3: 3411-B KEYBOARD TEST

This routine will display “--- ” until a key is depressed. As long as the key is depressed, a two-digit code is shown in the display. The code indicates the row and column of the depressed key. The left digit is the row. Table 2 below shows the keyboard and the key codes produced by the test routine. If other codes are produced or if only one code is shown and does not change, then the keyboard or associated circuits are defective.

NOTE

The depth switch must be in backscatter position for this test.

11	12	13	14
21	22	23	24
31		32	

Table 2. Key Codes for Keyboard Test Routines

3411-B Oscillator and Prescalers Test

To check the oscillator and the moisture and density prescalers:

1. Unscrew the front panel.
2. Slide the MEAS/TST switch to the TST position and replace the module.
3. Place the PWR/TIME switch to FAST.
4. Hold down the **<SHIFT>** key and press the **<STANDARD/MEASURE>** key.
5. At the end of 15 seconds, a 15646 ± 2 count should be in the MS, DS, MC, and DC registers.
6. Place the PWR/TIME switch on NORM and repeat.
7. At the end of 1 minute, 14646 ± 2 should again be stored in the registers.
8. Place the PWR/TIME switch on SLOW and repeat for the same indication at the end of 4 minutes.

Appendix A: Maintenance & Troubleshooting

This section covers the following topics and tasks:

- ✓ Maintenance tasks
- ✓ Troubleshooting
- ✓ Returning the gauge for service

Charging Batteries

A fully charged battery will last for eight weeks under normal working conditions before needing to be recharged. When the gauge displays **BAT** on the display, the gauge has only a few hours left before automatically turning off.

The batteries can then be fully recharged with the AC charger. Give the batteries a full charge when recharging; they cannot be overcharged.

For emergency use, a 30-minute recharge will allow several hours of usage. However, do not charge the batteries if the voltage is not low. Frequent, unnecessary recharging will shorten the battery life.

Mechanical Maintenance

To ensure the integrity of the source rod, Troxler recommends that a qualified service person inspect the gauge and the source rod periodically.

When the source rod is pulled out of the ground and into the safe position, the scraper ring should clean the source rod. This ring is located on the bottom plate at the base of the gauge. The scraper ring will keep the source area free of material that could damage the bearings. However, some material will collect in the cavity above the bottom plate.

To assure a long working life, clean the cavity regularly. The frequency of cleaning can vary from every day when in wet sands or wet concrete to a maximum of two weeks in regular soils.

Typical problems caused by insufficient maintenance may be the following:

- ◆ Difficulty raising or lowering the source rod.
- ◆ No “click” sound heard when the gauge is brought into the SAFE position.
- ◆ Erratic moisture or density counts.

To maintain this part of the gauge, follow these steps:

1. Position the gauge as described on B-12, Working with the Radiation Sources.
2. Stand to the side of the gauge (to limit exposure).
3. Clean the heads of the four screws that hold the bottom plate to the base of the gauge before removing them.
4. Remove the bottom plate.
5. Inspect the cavity for dirt buildup.

- a. If dirt is present, replace the scraper ring (Troxler part number 012752).
 - b. For reinstalling, note how the retaining ring and scraper ring are installed.
 - c. Remove the retaining ring from the back of the bottom plate with a screwdriver.
 - d. Remove the old scraper ring and replace it with a new one, and then reinstall the retaining ring.
6. Inspect the back of the bottom plate for wear. If there is significant wear, replace the bottom plate (part number 102067).
 7. Remove the sliding block, and if necessary, clean the block and the gauge carefully with a stiff brush, rag, or forced air.

NOTE

The source is now exposed. Stand to the side!

8. To lubricate the bearings, unscrew the top shell from the base (four screws) and raise the top shell to allow access to the grease fitting on the lower portion of the base.
9. Next, remove the set screw just below the grease fitting to allow overflow grease to run out.
10. Grease the bearing through the grease fitting with a Magnalube cartridge in a grease gun (3-4 shots is sufficient).
11. Replace the set screw, wipe excess grease away, and replace the top shell.
12. Replace the sliding block after cleaning. Orient the angle outside of the sliding block *upward* toward the source. If the sliding block is placed incorrectly, the source will not lower.
13. Apply a very light coat of Magnalube to the bottom plate in the area that the sliding block will make contact with.

If the source rod will not come down easily or not at all, the bearings will need to be changed. Send the gauge to a Troxler service center if the bearings need to be replaced.

Trigger Mechanism Assembly

This procedure is for replacing the trigger mechanism assembly on serial numbers 10245 and 10256 and above.

1. With the source rod in the SAFE or backscatter position, use a punch to drive the roll pin near the center of the handle to either side and almost out. Remove the plastic end cap of the handle. Before removing the punch, place your hand over the end of the handle to prevent the spring from flying out.
2. Unscrew the trigger from the indexer in the handle and slide the indexer out of the end of the handle.
3. Push the trigger up and pull it down to remove it. Tilt the gauge to remove the spring and indexer.
4. To reassemble, place the indexer and spring back in with the slanted face of the indexer facing up. Look through the hole to align the indexer.
5. Screw the trigger back into the indexer.
6. Using a small screwdriver, press the spring beyond the lock pin hole and hammer in the lock pin.

For gauges up to serial number 10255 (excluding 10245):

1. Place the gauge in the backscatter position.
2. Remove the lock pin from the index rod.
3. Unscrew the safety cap and raise the handle enough to be free of the index rod.
4. Remove the roll pin from the trigger and replace the indexer.

Gaskets

The gauge has three gaskets that will need to be checked at least once or twice a year. These gaskets will seal the gauge from the environment, and, if not inspected, moisture or water can get inside the gauge and cause damage.

- ◆ If there is an erratic count of moisture, a hair dryer can be used to dry the inside of the gauge.
- ◆ If the gauge is going to be stored for a long time, place the gauge in an air-conditioned room or blow dry the inside of the gauge to eliminate the possibility of moisture accumulation. Also, loosening or removing the scaler to allow the gauge to “breathe” will reduce moisture accumulation.

All the gaskets can be replaced without removing the radioactive source.

To remove the ***scaler gasket***, remove the scaler, remove the old gasket, and put the new gasket in place.

To remove the ***cover gasket*** and the ***base seal gasket***, remove the four screws that hold the cover and base together and raise the cover. Remove the old gaskets and replace with the new ones.

Troubleshooting

.The 3400-B instruments, while complex, can generally be repaired in the field by isolating problems to one or two modules by the process of elimination. The following list provides some troubleshooting hints for various situations.

Instrument fails to display when power is turned on.

- ▶ Batteries are discharged below cut-off voltage. Plugging in the charger will turn on the instrument.
- ▶ Check the receptacle into which the charger is plugged. Power may not be available to operate the charger. On older models fuses located on top of each battery back should be checked and replaced with Bussman type GMW 2 Ampere fuses, if necessary.

Charger lamps come on but unit still does not indicate a powered on condition. (Older model 3411 gauges have charger lamps.)

- ▶ Replace Battery Monitor Module.
- ▶ Replace Front Panel Module.*

Instrument turns on but will not indicate counting condition when MEASURE is attempted.

- ▶ Replace High Voltage Module.
- ▶ Replace Front Panel Module*.

* Before replacing the Front Panel Module, set the MEAS/TST switch on TST and attempt to accumulate a set of counts. If the TST count is correct, the front panel module is probably functioning correctly.

Instrument counts moisture but not density.

- ▶ Replace Density Module.
- ▶ Replace Front Panel Module*.
- ▶ Replace G-M tubes.

Instrument counts density but not moisture.

- ▶ Replace the Moisture Module.
- ▶ Replace the Front Panel Module*.
- ▶ Replace the He³ tube.

Instrument counts moisture and density but is erratic and will not meet stability test.

- ▶ Replace the Density or Moisture Module as required.
- ▶ Replace the High Voltage Module.
- ▶ Replace detectors/tubes as required.

Instrument counts moisture correctly, but density count is approximately half the normal value.

- ▶ Check for a defective contact at the G-M tube.
- ▶ Replace the defective G-M tube.
- ▶ Replace the Density Module.

3411-B Error Codes

Error Code	Indicated Failure Mode	Probable Cause
01	System failed internal test condition.	Microprocessor memory board hardware failure.
02	Accumulated number exceeds display size.	Position of PWR/TIME switch was changed during accumulation OR hardware failure on I/O board.
10, 11	Bad keyboard input.	Two keys depressed, defective keyboard or hardware failure on I/O board.
30	Microprocessor tried to evaluate the log of a negative number.	Incorrect depth selected by DEPTH switch.
30	Microprocessor attempted to divide by zero.	No standard counts in the MS or DS registers.
31	Negative overflow in division.	Incorrect depth selected by DEPTH switch OR standard or measure counts are not valid.
32	Positive overflow in division.	Same as above.
40	Invalid input from MOISTURE CORRECTION switches.	Switch failure, I/O board failure, or operator induced error during chain calculations.
41	Invalid input from DEPTH switch.	Same as above.

Calibration

The 3400 Series gauges are calibrated at the factory to relate count ratios to standards of known density and moisture. For density, materials that have proven to be dependable standards are: aluminum, magnesium, granite, limestone, and layered magnesium/polyethylene.

These standards cover the range of densities and moistures for which the gauges are used. They also have had the stability needed to calibrate the thousands of gauges built over the years.

To determine the calibration constants at the factory, gauge readings are taken on standards as described above. The data is processed to determine the calibration values for the particular gauge.

The common factors that affect the calibration over the life of the instrument are aging of electronics, decay of the source, shift in detector plateau, and field use.

If factory standards are not available, a designated spot on the concrete slab floor may be used for comparison. A historical base of readings can be developed by testing all gauges at the designated spot at the 4-minute count time when they come from the factory. These readings can be averaged, and then the serviced gauge can be compared to this average.

Also, another gauge can be used as a standard. Readings can be taken with a gauge that has a known good calibration. Then readings on the identical spot can be taken with the gauge in question. Be sure there are no gauges within 10 meters (30 ft.) of the gauge taking the reading. The 4-minute count is recommended for this procedure.

Some users construct standards of their own by packing soil in a box. In our experience, this method is very difficult and does not provide a dependable standard. Also, such standards often do not maintain a constant density or moisture over time.

If a local standard is to be constructed for density checking, we suggest any of the materials we use at the factory. We not recommend the use of any standards not fully checked at our factory for recalibration purposes.

Moisture calibration need not be checked as the detectors are very stable. Small changes can be corrected in the field when field samples are taken to develop a moisture correction factor.

If recalibration is necessary and Troxler standards are not available, contract your Troxler service center with calibration capability.

Returning the Gauge for Service

All shipments within the United States to the factory must be accompanied by a Returned Goods Authorization (RGA) number and a description of the unit and its problem. This information is used by Troxler personnel to expedite the repair work.

To obtain an RGA number, please complete the electronic form (available on the Troxler website) and fax it to the factory or branch office.

If you do not use the form, please have the following information available when contacting Troxler for an RGA number:

- ◆ Unit (or part) model and serial number
- ◆ Part number/serial number (if applicable)
- ◆ Problem or difficulty you are having with the unit
- ◆ Shipment method to Troxler and for return shipment
- ◆ Shipping and billing address (not P.O. box), including street address and ZIP code.
- ◆ Telephone number/contact person
- ◆ Payment method: credit card, account number, or purchase order number. **All government agencies (city, county, state, and federal) are required to send purchase order numbers.**

NOTE

To prevent order duplication, please write "Confirming Order" on any follow-up written requests.

Replacement Parts

Replacement parts and accessories can be order through your Troxler representative or by calling **1-877-TROXLER**.

Part Number	Description
110247	Advanced Control Unit (ACU)
103280	Battery Monitor Module (Rev)
102057	Battery Pack Assembly 3400 (2 required before SN 10278)
103681	Battery Pack Assembly 3400 (2 required after SN 10278)
102067	Bottom Plate Assembly 3400
102096.3400	Cap Screw (for Index Rod)
102103	Cap Screw Bumper
100528.1000	Captive Screws for Front Panel Model
103566	Density Amplifier Module Assembly
103825	Front Panel Overlay (Keypad) 3411-B
016245	Fuse 2 A Micro
100990	Gasket, Gauge
100989	Gasket-Molded for Base Post
102076	G-M Connector Assembly 3400
102077	G-M Mounting Assembly 3400
100158	G-M Tube, 3400
100993	Ground Spring for GM Detector
012779.3000	Handle Plug Cap Black (Handle for SN

	10245 and 10256 and after)
103276	HV Power Supply Assembly (1000 V)
102116	Indexer Assembly 3400 (before SN 10256 except 10245)
103021	LCD
012185	Lock with 2 Keys (H-1209)
012176	Lock with two keys (SN before 14410)
103397	Moisture PreAmp 6.5V Module
103787	Plunger 3400 (Indexer for SN 10245-14409)
104553	Plunger 3400 (Indexer for SN 10245-14409)
104639	HV Power Supply Assembly
102847	Processor (Complete) 3411-B
012753	Ring, Retaining (2 required)
101604.1610	Roll Pin 1/8 Dia X 1" (Trigger)
102140	Seal Retainer 3400
012752	Seal Wiper, Source Rod (SN before 12623)
012751	Seal, Source Rod Bearing (T. S-625)
102399	Shield Spring 3400
012200	Spring (SN 10245 and 10256 and above)
102075	Top Shell 3400
102069.1000	Wiper Cap, Source Rod (after SN 12623)
102069	Wiper Cap, 2400/3400

Optional Parts & Accessories

Part Number	Description
104411	AC Battery Charger (Domestic)
102118	AC Battery Charger (International)
102391	DC Charger Cable, 3400 (12 V)
004211	Drill Rod
103680.1000	Drill Rod Extraction Tool (Extractor)
102876.0005	Leak Test Replacement Packets (4 units)
021140	Radiation Sign Kit
103484	Reference Standard, 3400
102111	Scraper Plate
109661	Survey Meter

Maintenance Supplies

Part Number	Description
012784	Magnalube, 1.5 oz tube
012786	Magnalube, 1 lb can
012789	Magnalube, 14.5 oz
100761	Source Rod Pig

NOTES

Appendix B:

Radiation Theory & Safety

This section covers the following topics and tasks:

- ✓ Radiation theory and safety
- ✓ Working with radiation sources
- ✓ 3400-B radiation profile

Radiation Theory and Safety

For a more detailed discussion of radiological theory, please reference the *Troxler Nuclear Gauge Safety Training Program* manual, provided during the Troxler safety class or is available for purchase at our website (<http://www.troxlerlabs.com>).

Atomic Structure

All materials consist of chemical elements that cannot decompose by ordinary chemical methods. Some examples are:

(H) Hydrogen

(C) Carbon

(O) Oxygen

(U) Uranium

(Cf) Californium

(Co) Cobalt

Each element contains an atom with a unique structure. The atom consists of smaller particles such as protons, neutrons and electrons. The protons and neutrons are grouped together in the nucleus. The electrons orbit the nucleus (Figure 11). An atom is normally electrically neutral because the positive protons cancel out the negative electrons.

Protons carry a positive charge and are described as having a mass of one. Neutrons have a neutral charge and also have a mass of one. Electrons carry a negative charge and essentially have no mass.

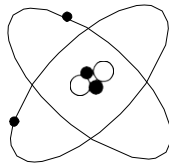

Figure 12. Diagram of an Atom

Because protons and neutrons are clustered together in the nucleus, the mass of an atom is concentrated in the nucleus. The atom in Figure 13 has two protons and two neutrons; therefore, it is a helium atom. The atomic weight of an atom is the sum of the protons and neutrons.

	Mass (Atomic Weight Scale)	Charge
Protons	1.0073	+1
Neutrons	1.0087	0
Electrons	0.0006	-1

Radiation Theory

Radioactivity is the spontaneous breakdown of unstable nuclei (radioisotopes) with the resulting emission of radiation. The basic unit of radiation used in the U.S. is the curie (Ci) and is defined as 3.7×10^{10} disintegrations of nuclei per second. In the "Special Form," encapsulated sealed sources used in the a 3400 series gauge, the unit of measure is the millicurie (1/1,000 of a curie). The SI unit of radiation is the Becquerel and is equal to one disintegration per second. Therefore, one curie equals 3.7×10^{10} Becquerels.

The strength of radioactive material is measured by its activity, or rate of decay. This activity decreases with time. The length of time it takes a given amount of radioactive material to decay to half of its original strength is referred to as the "half-life." The half-life of cesium-137 is 30 years, while that of americium-241:beryllium is 432 years.

Radiation Terminology

Various standards for the measurement of radiation exist, but only two concern the Troxler 3400-B Series gauge user. These units are the *curie*, which expresses activity of the source, and the *rem* (roentgen equivalent man). The curie, defined as the quantity of radioactive material giving 3.7×10^{10} disintegrations per second, is equal to the number of disintegrations/second of one gram of radium-226. Note that the source used in the 3400 series gauges is small, with quantities expressed in millicurie (mCi).

The *rad* or "radiation absorbed dose," is the unit of absorbed dose that is equal to 0.01 Joules/kg in any medium. In order to take into consideration the effect of various types of radiation on biological tissue, the *rem*, or more appropriate for Troxler users—the millirem—is used to measure radiation dosage. The unit *rem* is derived from scaling the radiation absorbed dose (*rad*) by a quality factor (QF). One *rad* is equal to the exposure of one *rem* of photon radiation. For example, the average neutron energy of an americium-241:beryllium source is about 4.5 MeV. The quality factor (QF) for this radiation is about 10. The absorbed dose of 1 *rad* of neutron radiation produces a dose equivalent of (absorbed dose x QF) 10 *rem*.

Occupational exposure limits are set by government agencies. The current limit in the United States and many other countries is 5,000 millirem per year. Under average conditions, a full time employee working with a 3400 series gauge will receive less than 200 millirem per year.

Anyone working with or near radioactive materials is subject to the limits on occupational exposure mentioned earlier and must complete a radiation safety training course to be designated an authorized user. As an authorized user, an individual so designated must work in a "controlled" environment to the extent that their exposure to radiation must be monitored. Several means of personnel monitoring or *dosimetry* exist; the most common methods are film badges and TLD badges.

Radiation Statistics

Radioactive emission is a random process. The number of emissions in a given time period is not constant but varies statistically about an average value. The variation about the true mean value is a Poisson distribution. In this distribution, the standard deviation (σ) about the mean (n) is defined as:

$$\sigma = \sqrt{n}$$

When the mean is greater than 100, the Poisson distribution can be closely approximated by the normal distribution (Figure 12). The normal distribution predicts the probability that any given count rate will fall within a selected region about the mean.

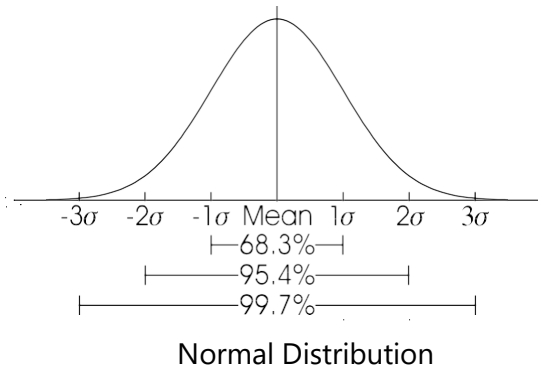

Figure 13. Variation of Radioactive Emission

Using the mean of a larger number of counts to approximate the true mean, the distribution shows that 68.3% of the time the count rate obtained will be within ± 1 standard deviation of the mean. Figure 14 shows the probabilities for three different standard deviations. A statistical stability test may be performed to compare the experimental standard deviation to the theoretical standard deviation.

Radiation Safety

This section provides a brief discussion of general radiation safety. The exposure profile for a 3400 series gauge is also included, along with a discussion of the source encapsulation.

TYPES OF RADIATION

The radioactive sources in a 3400 series gauge produce three types of radiation:

Alpha Particles

Photons

Neutrons

The alpha particles are stopped by the source capsule. Only the photon and neutron radiation contribute to the occupational radiation exposure.

Photon radiation is electromagnetic radiation, as are x-rays, radio waves and visible light. Visible light and photon have no mass, a zero electrical charge and travel at the speed of light. Photons are energetic and penetrating. Dense materials provide the best shielding against photon radiation.

Neutron radiation allows measurement of the hydrogen (water) content in a material because the neutrons are slowed by collisions with materials containing hydrogen atoms (e.g., water, polyethylene). Neutrons have a neutral charge and are very penetrating.

LIMITING EXPOSURE

Current regulations for both NRC and Agreement States have established a whole body occupational exposure limit of 5,000 millirem per year. Under normal conditions a full time operator of a 3400 series will receive less than 200 millirem per year.

Taking advantage of all available means to limit radiation exposure is always recommended. The three methods of limiting exposure are:

Time
Distance
Shielding

These methods are a part of an "**ALARA**" (**As Low As Reasonably Achievable**) program.

TIME

The simplest way to reduce exposure is to keep the time spent around a radioactive source to a minimum. If time is cut in half, so is the exposure, with all other factors remaining constant.

DISTANCE

Distance is another effective means to reduce radiation exposure. A formula known as the "inverse square law" relates the radiation exposure rate to distance (Figure 15). Doubling the distance from a radiation source reduces the exposure to one-fourth its original value. If the distance is tripled, the exposure is reduced by a factor of nine, etc.

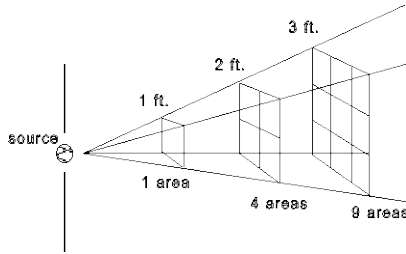

Figure 14. Effects of Distance on Exposure

SHIELDING

Shielding is any material used to reduce the radiation reaching the user from a radioactive source. While some types of radiation such as alpha particles may be stopped by a single sheet of paper, other particles such as neutrons and photons require much more shielding. Materials containing large amounts of hydrogen, such as polyethylene, are used to shield neutrons. Dense materials, such as lead, are used to shield photons. The 3400 series gauges have shielding built into the system which reduces the exposure.

3400-B Radiation Profile

GAUGE	SURFACE			10 cm			30 cm			1 meter		
	GAMMA	NEUTRON	TOTAL	GAMMA	NEUTRON	TOTAL	GAMMA	NEUTRON	TOTAL	GAMMA	NEUTRON	TOTAL
FRONT	4.0	1.0	5.0	0.4	0.5	0.9	.16	0.1	0.26	0.06	0.01	0.07
BACK	14.0	1.0	15.0	1.5	0.5	2.0	0.18	0.1	0.28	0.02	0.01	0.03
SIDES	13.0	1.0	14.0	2.5	0.5	3.0	0.6	0.1	0.7	0.1	0.01	0.11
TOP	6.0	0.5	6.5	0.52	0.2	0.72	0.2	0.05	0.25	0.08	0.01	0.09
BOTTOM	9.0	3.0	12.0	0.7	1.0	1.7	0.18	0.1	0.28	0.05	0.01	0.06
HANDLE	0.2	0.32	0.52	0.09	0.21	0.3	0.01	0.05	0.06	*	*	*

Table 3. Radiation Profile

Notes

1. Gamma measurements made with a Victoreen Model 2035 survey meter, calibrated Nov. 16, 1981.
2. Neutron measurements made with Nuclear Research Corp. Model NP-2 survey meter, calibrated Feb. 28, 1982.
3. Dose Rates are for 8 mCi Cs-137 gamma source and 40 mCi am-241:besource
4. * indicates a reading less than 9.1 mrem/hr.
5. All units are in mrem/hr.

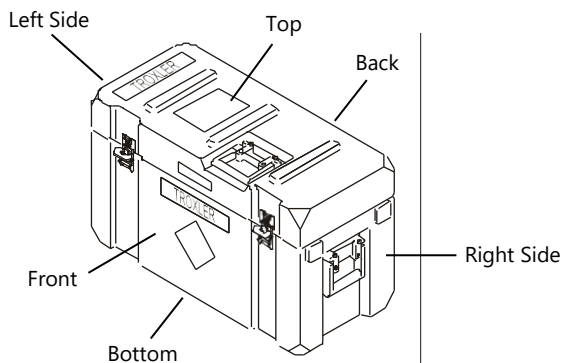

	SURFACE			30 cm			1 meter		
3401 IN CASE	GAMMA	NEUTRON	TOTAL	GAMMA	NEUTRON	TOTAL	GAMMA	NEUTRON	TOTAL
RIGHT	4.0	1.1	5.1	0.5	0.3	0.8	0.2	*	0.2
TOP	6.0	0.3	6.3	0.5	*	0.5	0.2	*	0.2
LEFT	0.3	0.1	0.4	0.2	*	0.2	*	*	*
BOTTOM	6.05	0.4	6.9	1.9	0.1	2.0	0.4	*	0.4
BACK	5.0	0.4	5.4	0.9	*	0.9	0.2	*	0.2
FRONT	5.0	0.3	5.3	0.7	0.1	0.8	0.8	*	0.8
3411 IN CASE	GAMMA	NEUTRON	TOTAL	GAMMA	NEUTRON	TOTAL	GAMMA	NEUTRON	TOTAL
RIGHT	5.0	0.8	5.8	0.4	0.3	0.7	0.2	*	0.2
TOP	4.0	0.3	4.3	0.5	*	0.5	*	*	*
LEFT	0.4	*	0.4	0.2	*	0.2	*	*	*
BOTTOM	6.0	0.3	6.3	1.3	0.1	1.4	0.5	*	0.5
BACK	5.0	0.4	5.4	0.8	*	0.8	0.2	*	0.2
FRONT	4.0	0.4	4.4	0.7	*	0.7	0.2	*	0.2

Table 3 (continued)

Notes

1. Gamma measurements made using Ludlum 14C survey meter, calibrated March 1990.
2. Neutron measurements made with Nuclear Research Corp. Model NP-2 survey meter, calibrated March 1990.
3. Dose rates for 8 mCi Cs-137 source and a 40 mCi Am-241:ber source.
4. * indicates a reading less than 0.1 millirem/hr.
5. Surface indicates surface of case.
6. All readings in millirem/hr.

Source Encapsulation

The sources in the 3400 series gauges meet regulatory requirements of U.S. and international authorities as *Special Form*, or encapsulated, sealed source material. The "sealed" sources used are encapsulated to prevent leakage of the radioactive material and meet radiation safety requirements.

The neutron source (americium-241:beryllium) is compressed and welded inside stainless steel capsules.

The photon source (cesium-137) is sealed in a welded capsule.

The only radiological health concerns to Troxler 3400-B Series gauge users are the photon and neutron emissions for moisture and density measurement. Proper use of this instrument (following the instructions in this manual) and the shielding design of the instrument will keep the exposure levels at a minimum under normal conditions. It is, however, likely required that personnel dosimetry be used when operating the gauge.

Working with Radiation Sources

The 3400-B series contains two radioactive sources. The Am-241:Be source is located in the center of the gauge base. **Never attempt to remove this source!**

The Cs-137 source is welded inside the tip of the source rod. When located in the SAFE (shielded) position, the source is surrounded on all sides by tungsten and radiation is reduced to safe levels. The source rod does not need to be removed to troubleshoot the scaler and preamplifier board.

NOTE

When performing maintenance on the gauge, always monitor radiation by wearing an dosimeter.

To perform routine maintenance, you may need to remove the bottom shield to clean the cavity beneath the source. To minimize exposure while cleaning, proceed as follows.

1. With the source in the SAFE position, place the gauge on its side.
2. Remove the bottom plate.
3. Remove the sliding tungsten shield. When removing the shield, stand to the side of the gauge to minimize exposure.
4. Move away from the gauge and keep others away when shielding is not present.
5. Dry the block well. Lightly grease the top sloped surface of the block and quickly replace the spring, block, and baseplate.

This procedure will keep exposure to minimum levels. Exposure to the hands will be higher than to the body, but is well within safe levels established by radiation authorities. The cleaning operation should be conducted quickly and will not take more than five minutes.

Appendix C:

Theory of Operation

This section covers the following topics and tasks:

- ✓ How the gauge detects moisture and density

Density

Figure 16 represents the geometry for the direct transmission and backscatter modes of the 3400 series. An 8 mCi (0.3 GBq) Cs-137 source is located in the tip of the rod. Gamma photons emitted by the source radiate to the detectors. Some of the photons emitted by the source collide with electrons in the soil, reducing the amount of gamma photons reaching the detectors.

For the backscatter mode, photons must be "scattered" at least once to reach the detectors. The electron density is directly related to mass density. Counts over a time such as 1 minute can be directly related to density as shown in the section on calibration.

In direct transmission, photons reaching the detector must pass through the full distance from the source to the detectors. The density measurement is an average of the material between the source depth and the gauge base.

In backscatter, photons must be scattered at least once to reach the detectors. This geometry yields a reading which is biased toward the surface. Figure 17 shows the portion of the reading taking place in the top layer. For example, approximately 94% of the reading takes place in the 80 mm (3 in.) of material measured.

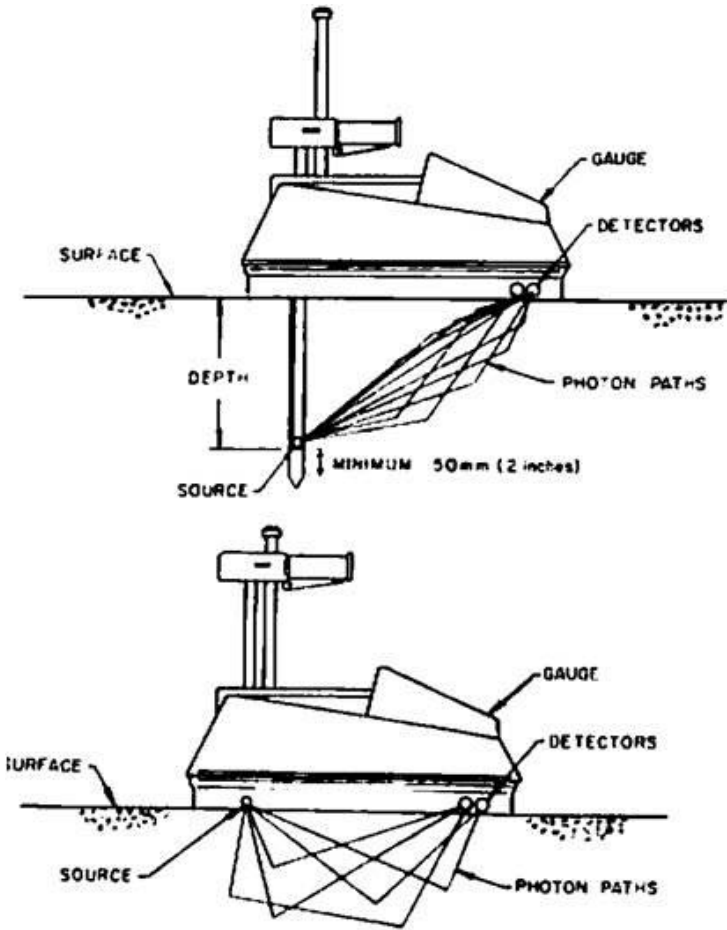

Figure 15. Direct Transmission and Backscatter Geometries

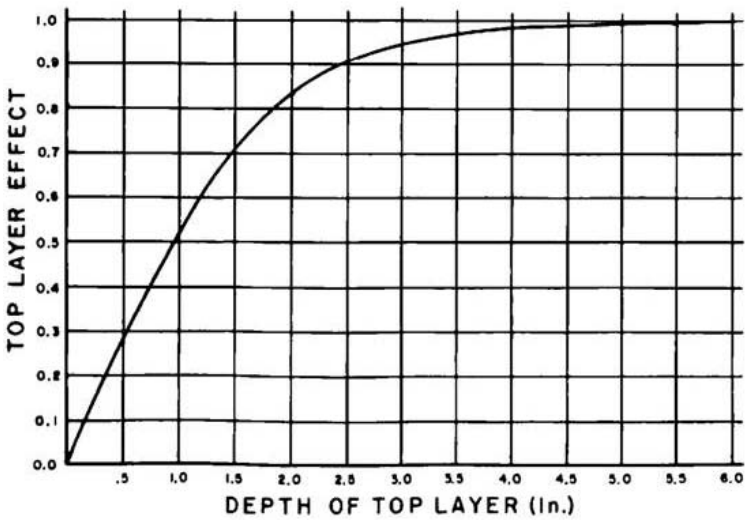
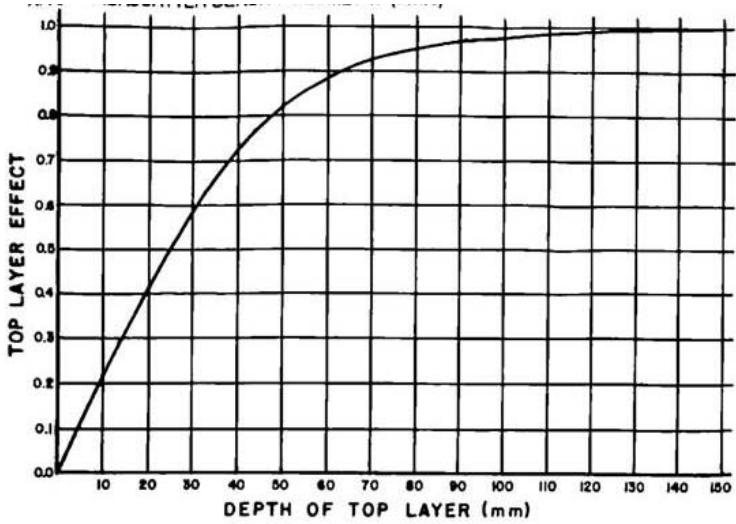

Figure 16. Backscatter Surface Density Effects

Moisture

The 3400 Series utilizes a 40 mCi (1.48 GBq) Am-241:Be source with a yield of 70,000 neutrons per second. The neutrons are used to measure hydrogen concentration in a material which will be related to moisture (water) content. Hydrogen can be measured with neutrons because hydrogen *thermalizes* (slows) neutrons.

This means that fast neutrons emitted by the source are slowed to a velocity where additional collisions with hydrogen or other molecules will not slow the neutrons any further. About 19 collisions with hydrogen are required to thermalize a neutron.

For elements other than hydrogen to thermalize a neutron, far more collisions are necessary (see Table 4). Generally, the larger the element's atomic weight, the more collisions are required to slow the neutron.

Since soils will contain varying amounts of compounds containing hydrogen other than water, the gauge may require calibration for individual soils. Also, some elements absorb neutrons into their nucleus. The absorption cross section indicates the probability the neutrons will be absorbed. Table 4 lists absorption cross sections of several elements. Boron and chlorine are typical problem elements, since they have high absorption cross sections.

Gauges are calibrated at the factory to measure moisture in an ideal soil without neutron absorbing elements or chemically bound hydrogen. In the field, adjustments to calibration are generally done by comparison with conventional type tests such as oven dry. Calibration is described in Appendix A.

A helium-3 (He^3) tube is used to detect thermalized (slowed) neutrons. The tube is insensitive to fast neutrons, so no shielding is required between the source and the detector. Generally, the counts obtained from a He^3 tube are directly proportional to hydrogen, or moisture, content.

Neutron Thermalization and Absorption Data		
Element	Collisions to Thermalization	Absorption Cross Section
Hydrogen	19.0	0.33
Boron	109.2	750.00
Carbon	120.6	0.0034
Nitrogen	139.5	1.90
Oxygen	158.5	0.0002
Sodium	224.9	0.53
Magnesium	237.4	0.063
Aluminum	262.8	0.23
Silicon	273.3	0.16
Phosphorous	300.8	0.19
Sulfur	311.1	0.51
Chlorine	343.3	33.00
Potassium	378.0	2.10
Calcium	387.3	0.43
Titanium	461.6	6.10
Manganese	528.5	13.30
Iron	537.2	2.53
Cadmium	1474.6	2390.00
Lead	1975.5	0.17
Uranium	2268.6	4.20

Table 4. Neutron Thermalization and Absorption Data

Defining the depth of measurement for moisture is straightforward, since the moisture depth of measurement is a function of the moisture content and decreases with an increase in moisture. A set of normalized curves is shown in Figure 18, which illustrates the effect of moisture content on the depth of measurement.

Using the data taken to arrive at the curves shown in Figure 18. Effect of Moisture on Depth, one can express the relationship between the depth and the moisture content as:

$$\text{Depth (in)} = 11 - 0.17 M \text{ (pcf)}$$

or

$$\text{Depth (mm)} = 280 - 0.27 M \text{ (kg/m}^3\text{)}$$

This equation covers 98% of the measured volume and is valid over the moisture content range of 0-640 kg/m³ (0-40 pcf).

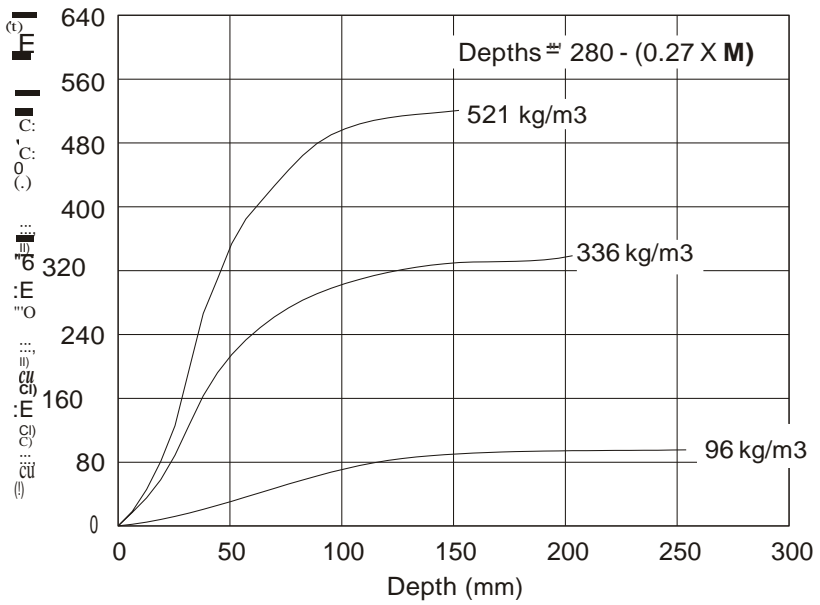
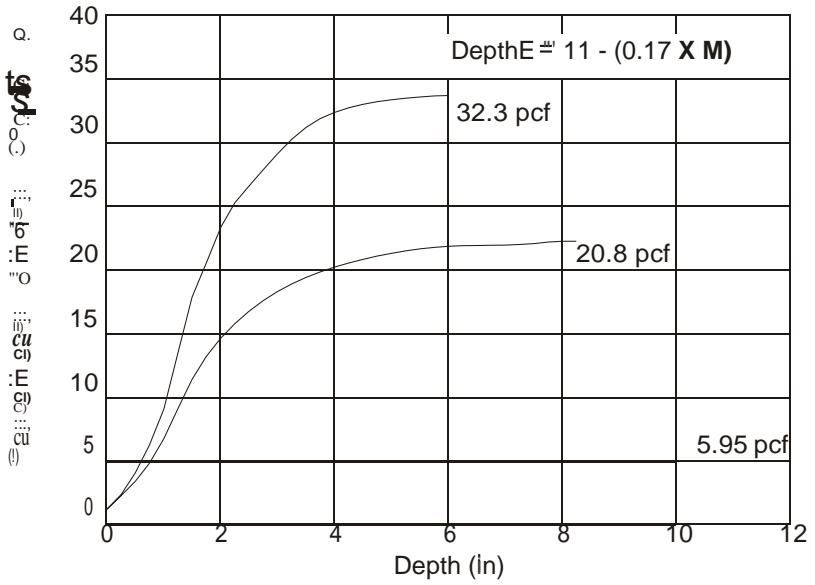

Figure 17. Effect of Moisture on Depth

Appendix D: Specifications

This section covers the following topics and tasks:

- ✓ Measurement specifications
- ✓ Mechanical specifications
- ✓ Calibration specifications
- ✓ Radiological specifications
- ✓ Electrical specifications

Measurement Specifications

Backscatter Density	Fast	Normal	Slow	
Precision at 2000 kg/m ³	16.6	8.30	4.15	±kg/m ³
(125 pcf)	1.04	0.52	0.26	±pcf

Depth of Measurement (98%) 100 mm (4 inches)

Direct Trans. Density	Fast	Normal	Slow	
Precision at 2000 kg/m ³	9.38	4.69	2.35	±kg/m ³
(125 pcf)	0.59	0.29	0.15	±pcf

Depth of Measurement 50-300 mm (2-12 inches)

Moisture Content	Fast	Normal	Slow	
Precision at 250 kg/m ³	11	5.50	2.75	±kg/m ³
(15.6 pcf)	0.69	0.34	0.17	±pcf

The precisions stated are the standard deviation of 20 tests for an average gauge. The precision defines the repeatability of measurement.

There are two other factors that affect accuracy of nuclear gauges on soils and asphalt: chemical composition and surface roughness.

For backscatter density measurement, the maximum bias due to chemical composition for soil or asphalt is 40 kg/m³ (2.50 pcf).

For direct transmission density measurement, the maximum bias is 22 kg/m³ (1.40 pcf). Pure granite represents the maximum of a material on which the gauge will read low. Pure limestone represents the maximum of a material on which the gauge will read high.

For moisture, variance in chemical composition will be compensated for by the moisture correction procedure (see page 5-5).

Surface roughness causes a negative bias, increasing with the amount and size of voids underneath the gauge. For backscatter density, a 100% void of 1.25 mm (0.05 inches) will cause a negative bias of a 64.4 kg/m^3 (4.00 pcf).

For direct transmission density, a 100% void of 1.25 mm (0.05 inches) will cause a negative bias of 14.4 kg/m^3 (0.90 pcf).

For moisture, a 100% void of 1.25 mm (0.05 inches) will cause a negative bias of 17.6 kg/m^3 (1.10 pcf).

Mechanical Specifications

Gauge base and topshell	Aluminum casting
Vibration test	2.5 mm (0.1 inches) at 12.5 Hz
Drop test	300 mm on 25 mm diameter steel ball
Operating temperature	Ambient: -10 to 70°C (14 to 158°F) Surface: 170°C (350°F)
Storage temperature	-55 to 85°C (-70 to 185°F)
Gauge size (excluding handles)	368 x 229 x 183 mm (14.5 x 9.0 x 7.2 inches)
Gauge height (including handles)	495 mm (19.5 inches) or 395 mm (15.5 inches)
Shipping weight	37.2 (92 pounds) with transport case

Calibration Specifications

Accuracy of density standards	±0.1%
Accuracy of moisture standards	±4.0%
Calibration range	70-170 pcf density 0 - 40 pcf moisture

Method: Computer reduction of count rate data based on US National Bureau of Standards Photon Cross Sections, Neutron Cross Sections, and Absorption Coefficients. Data is reduced to the form $D = (\ln(A/CR + C))/B$ for density and $M = (CR - E)F$ for moisture where A, B, C, E, and F are constants and CR is count ratio.

Field Data Conversion

3401-B: Gauge users are supplied with conversion tables for wet density and moisture content; users must compute dry density, percent moisture, and percent compaction.

3411-B: Contains a microprocessor providing direct reading in both SI and US Customary units for wet density, dry density, moisture content, and percent moisture. The algorithm corrects for hydrogen photon scattering coefficients and provides means for offsetting non-water hydrogen.

If the optimum density has been preset by the operator, the microprocessor can compute % of Marshall or % of Proctor.

A method has also been provided to allow operators to negate the effects of sidewall moisture, if necessary.

Radiological Specifications

Gamma source	0.40 GBq (8 mCi) \pm 10% cesium-137, TEL A-10112
Neutron source	1.48 GBq (40 mCi) \pm 10% Americium- 241:Beryllium with 70,000 N/sec yield, TEL A-102451
Source form	Stainless steel, double encapsulated
Shielding	Tungsten and lead
Surface dose rates	15 mrem/hour max, neutron and gamma
Source rod containment	Stainless steel, 55 C Rockwell hardness
Shipping case	DOT 7A, Type A, Yellow II Label 0.1 – TI
Source seal approval for domestic and international shipment	Am-241:Be, Special Form Certificate GB:SFC 7

Electrical Specifications

Time accuracy and stability	$\pm 0.005\%$ $\pm 0.0002\%/^{\circ}\text{C}$
Power supply stability	$\pm 0.01/^{\circ}\text{C}$
Stored power	40 watt-hours
Battery recharge time	14 hours
Charge source	110/220V, 50-60 Hz or 12-14 VDC (negative ground)

	3401-B	3411-B
Readout (LCD)	4 digits	4 ½ digits
Largest number displayable	9999	19999
Count registers (moisture, density)	2	2
Power consumption (watts)	0.09	0.15
Power consumption after automatic battery cutoff (watts)	0.001	0.001

Battery packs are protected against overcharge and over discharge. A low battery alarm is indicated by the display several hours prior to automatic shutoff.

Appendix E: Standard Count Log

STANDARD COUNT LOG

Serial Number _____

Date	Moisture - MS	Density - DS	Date	Moisture - MS	Density - DS

NOTES

TROXLER ELECTRONIC LABORATORIES, INC.

LIMITED WARRANTY

TROXLER ELECTRONIC LABORATORIES, INC., and subsidiary, TROXLER INTERNATIONAL, LTD., hereinafter referred to as "TROXLER," warrants this instrument, Model _____, Serial Number _____, against defects in material and workmanship for a period of twelve (12) months from date of shipment. For products sold through authorized TROXLER representatives, the date of shipment will be as of the transfer from representative to purchaser. During the applicable warranty period, TROXLER's obligation under this warranty shall be limited exclusively to the repair at a TROXLER facility at no charge, except for shipping to and from TROXLER'S plant, of any instrument which may prove defective under normal use and which TROXLER's examination shall disclose to its satisfaction to be thus defective. Normal use is defined for the purpose of this warranty as operation under normal load, usage, and conditions with proper care and maintenance and competent supervision. In no event shall TROXLER be held liable for damages, delays, or losses consequential, incidental, or otherwise attributable to the failure of this instrument. TROXLER's liability being specifically limited to repair as stated hereinabove. This warranty is automatically initiated except where modified by contractual or other written and signed agreement.

THERE ARE NO WARRANTIES WHICH EXTEND BEYOND THE DESCRIPTION ON THE FACE HEREOF, AND THIS WARRANTY IS EXPRESSLY IN LIEU OF ALL OTHER WARRANTIES, EXPRESSED OR IMPLIED, AND TROXLER NEITHER ASSUMES, NOR AUTHORIZES ANYONE TO ASSUME FOR IT ANY OTHER LIABILITY IN CONNECTION WITH THE SALE OF THE INSTRUMENT. THIS WARRANTY SHALL NOT APPLY TO THE INSTRUMENT OR ANY PART THEREOF, WHICH HAS BEEN SUBJECTED TO DAMAGE BY ACCIDENT, NEGLIGENCE, ALTERATION, ABUSE, MISUSE, OR SERVICE NOT AUTHORIZED IN WRITING BY TROXLER. SUCH DAMAGE TO INCLUDE BUT NOT BE LIMITED TO BURNING OF CIRCUIT BOARDS AND HARNESS FROM IMPROPER SOLDERING TECHNIQUES AND DAMAGE TO THE INSTRUMENT DUE TO PURCHASER'S FAILURE TO PERFORM MAINTENANCE AS OUTLINED IN THE AUTHORIZED OPERATOR'S MANUAL. DUE TO THE NATURE OF THEIR USE, MECHANICAL ACCESSORY PARTS AND BATTERIES ARE WARRANTED FOR 90 DAYS ONLY FROM DATE OF SHIPMENT.

TROXLER ELECTRONIC LABORATORIES, INC.

Troxler International, Ltd.
3008 Cornwallis Road
Post Office Box 12057
Research Triangle Park, NC 27709 USA

NOTICE TO CONSUMERS

Any disclaimer or limitation on the remedies expressed above shall not be effective to the extent prohibited by state or federal law.

NOTE: THIS WARRANTY EXCLUDES DAMAGE INCURRED IN SHIPMENT. IF THIS INSTRUMENT IS RECEIVED IN DAMAGED CONDITION, THE CARRIER SHOULD BE CONTACTED IMMEDIATELY. ALL CLAIMS FOR DAMAGE IN TRANSIT SHOULD BE FILED WITH THE CARRIER. IF REQUESTED, TROXLER WILL AID IN FILING OF CLAIMS AND/OR LOCATING PRODUCTS LOST IN TRANSIT.